

Bluetooth
 808-0817-02 only

⚠️ DANGER

HAZARD OF FIRE, ELECTRIC SHOCK, EXPLOSION, OR ARC FLASH
 This Freedom X Remote Panel User Guide is in addition to, and incorporates by reference, the relevant product manuals for each product in the Freedom X series. Before reviewing this guide you must read the relevant product manuals. Unless specified, information on safety, specifications, installation, and operation is as shown in the primary documentation received with the product. Ensure you are familiar with that information before proceeding.
Failure to follow these instructions will result in death or serious injury.

Exclusion for Documentation
 UNLESS SPECIFICALLY AGREED TO IN WRITING (SELLER) MAKES NO WARRANTY AS TO THE ACCURACY, SUFFICIENCY OR SUITABILITY OF ANY TECHNICAL OR OTHER INFORMATION PROVIDED IN ITS MANUALS OR OTHER DOCUMENTATION; (B) ASSUMES NO RESPONSIBILITY FOR LOSSES, DAMAGES, COSTS OR EXPENSES, WHETHER SPECIAL, DIRECT, INDIRECT, CONSEQUENTIAL OR INCIDENTAL, WHICH MIGHT ARISE OUT OF THE USE OF SUCH INFORMATION; THE USE OF ANY SUCH INFORMATION WILL BE AT THE USER'S RISK; AND (C) REMINDS YOU THAT IF THIS MANUAL IS IN ANY LANGUAGE OTHER THAN ENGLISH, THAT THE STEPS HAVE BEEN TAKEN TO MAINTAIN THE ACCURACY OF THE TRANSLATION; THE ACCURACY CANNOT BE GUARANTEED.

1

Introduction

Thank you for purchasing the Freedom X Remote Panel. This user guide will help you install and use the remote panel to operate and configure the Freedom X and XC series remotely.

What's In The Box

- Check that you have the following items in the box before proceeding.
- the Freedom X remote panel unit
 - user guide and mounting template
 - 25-ft. 6-conductor cable kit (808-0817-02 unit only)

FCC/IC Information to the User
 This device complies with Part 15 of the FCC Rules/Canada Industry licence-exempt RSS standard(s). Operation is subject to the following two conditions: (1) This device may not cause harmful interference. (2) This device must accept any interference received, including interference that may cause undesired operation.
NOTE: This equipment has been tested and found to comply with the limits for a Class B digital device, pursuant to Part 15 of the FCC Rules. These limits are designed to provide reasonable protection against harmful interference in a residential installation. This equipment generates uses and can radiate radio frequency energy and, if not installed and used in accordance with the instructions, may cause harmful interference to radio communications. However, there is no guarantee that interference will not occur in a particular installation. If this equipment does cause harmful interference to radio or television reception, which can be determined by turning the equipment off and on, the user is encouraged to try to correct the interference by one or more of the following measures:
 • Reorient or relocate the receiving antenna.
 • Increase the separation between the equipment and the receiver.
 • Connect the equipment to a circuit different from that to which the receiver is connected.
 • Consult the dealer or an experienced radio/TV technician for help.
WARNING: Changes or modifications not expressly approved by the party responsible for compliance could void the user's authority to operate the equipment.
RF Exposure: The equipment has been evaluated to meet general RF exposure requirement. The device can be used in portable condition without restriction.
 FCC ID: 2AODL-FXRP-BT / IC: 23407-FXRPBT

2

What's Required

- If you received the 808-0817 unit, you need to acquire one of the following 6-conductor cable kit from Xantrex.
- 25-ft. 6-conductor cable kit (PN: 31-6257-00)
 - 50-ft. 6-conductor cable kit (PN: 31-6262-00)

Installation

1. Prepare the remote panel unit and the 6-conductor com cable kit.
2. Choose a location for the remote panel unit within reach of the com cable and the inverter unit.
3. Use the mounting template (in section A) to make the installation of the remote panel easier.
4. Mount the remote panel unit.
5. If you have a Freedom 458 unit, you may use it with the Freedom X Remote Panel. Installation instructions are available in section B.

3

Features

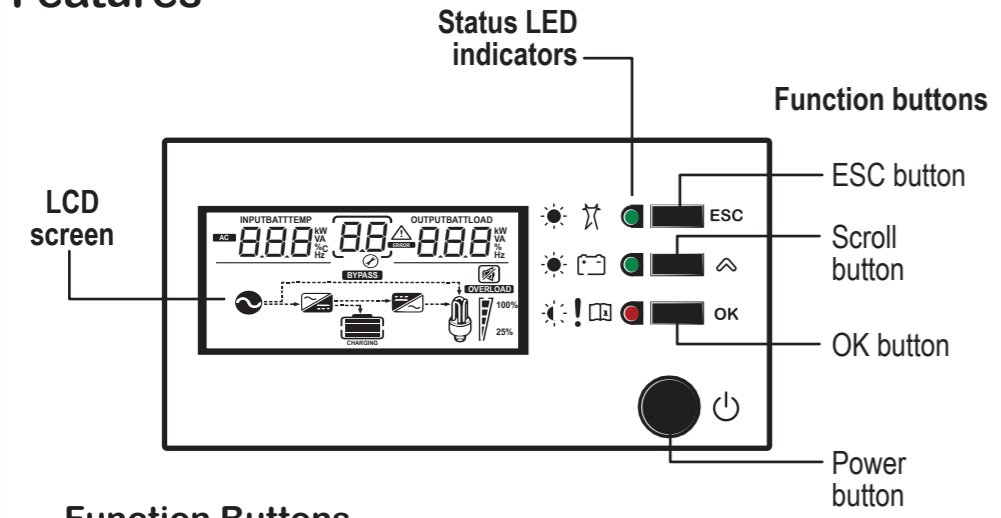

Function Buttons

	return to default screen or exit setting mode
	next screen or next selection
	to enter the setting mode or to confirm the setting
	turns the inverter unit on or standby NOTE: Only when the inverter's Power button is off

NOTE: Briefly pressing any function button activates backlight illumination. After 60 seconds of inactivity, backlight illumination turns off.

Status LED Indicators

	Indicates grid mode in which shore power is available and passing through to the loads and charging the battery.
	Indicates battery mode (inverter mode) in which the inverter is running and supplying power to the loads from the battery.
	Indicates error or fault mode and is accompanied by an error code displayed on the LCD screen.
	Indicates a warning condition and is accompanied by an error code and a sounding alarm.

LCD Screen

	AC input and output indicator.
	The wrench icon underneath a number is displayed during configuration mode.
	An error event with its corresponding number is displayed here.
	A warning event with its corresponding number is displayed here.
	The battery icon indicates remaining battery power. One bar = 1-25%, two bars = 25-50%, three bars = 50-75%, and four bars = 75-100%.
	Shows an AC output overload condition.
	The load icon is displayed if there is voltage available at the AC output.

4

Viewing Information During Battery Mode

Press scroll [↵] to move to the next screen. Press [ESC] to return to the home screen 1.

	The bar represents load consumption levels. 100% is an indication of full capacity and 25% indicates low consumption. All the bars disappear at < 20 watts, and AC load indicates zero watt power.
	Shows up in grid mode when AC shore power is present. If the power is being qualified, then this icon will flash.
	Shows that the unit is in grid mode and is bypassing shore power directly to the loads.
	This icon shows when there is power conversion from AC to DC - charging. Applicable only to Freedom XC units.
	This icon shows when there is power conversion from DC to AC - inverting.
	The alarm buzzer is muted. For more information, see Freedom inverter's Owner's Guide.

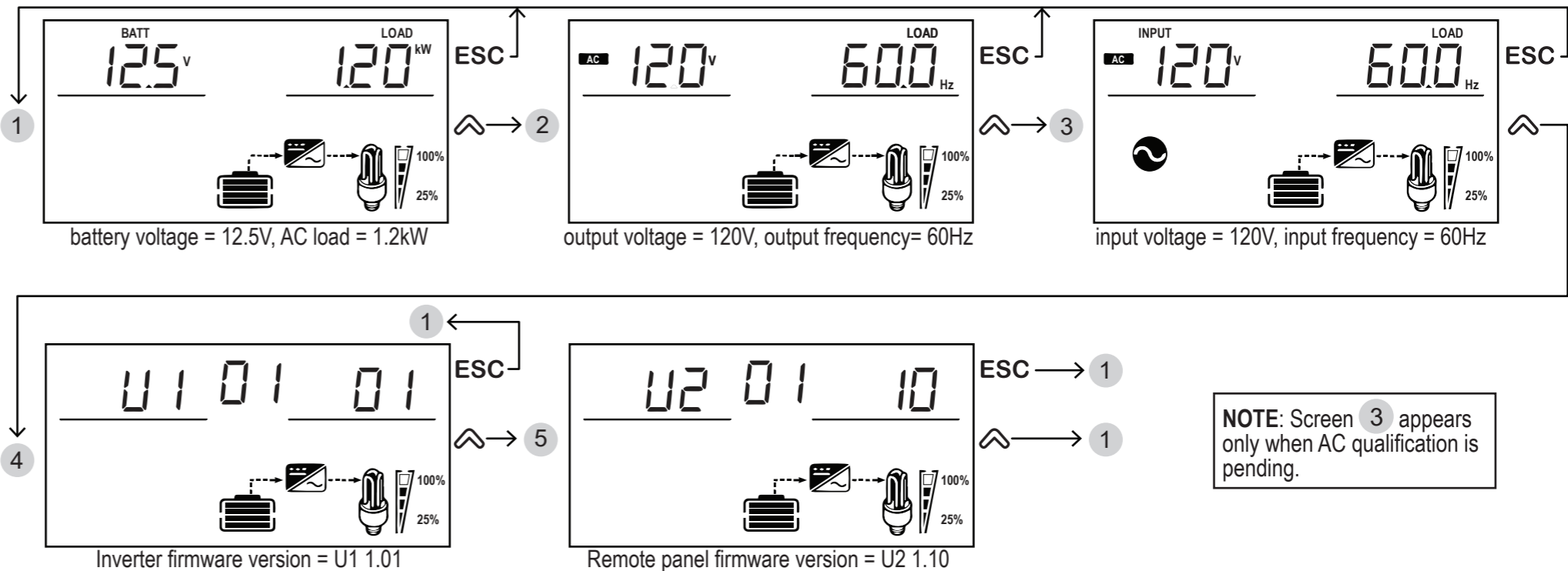

5

Viewing Information During Grid Mode

Press scroll [↵] to move to the next screen. Press [ESC] to return to the home screen 1.

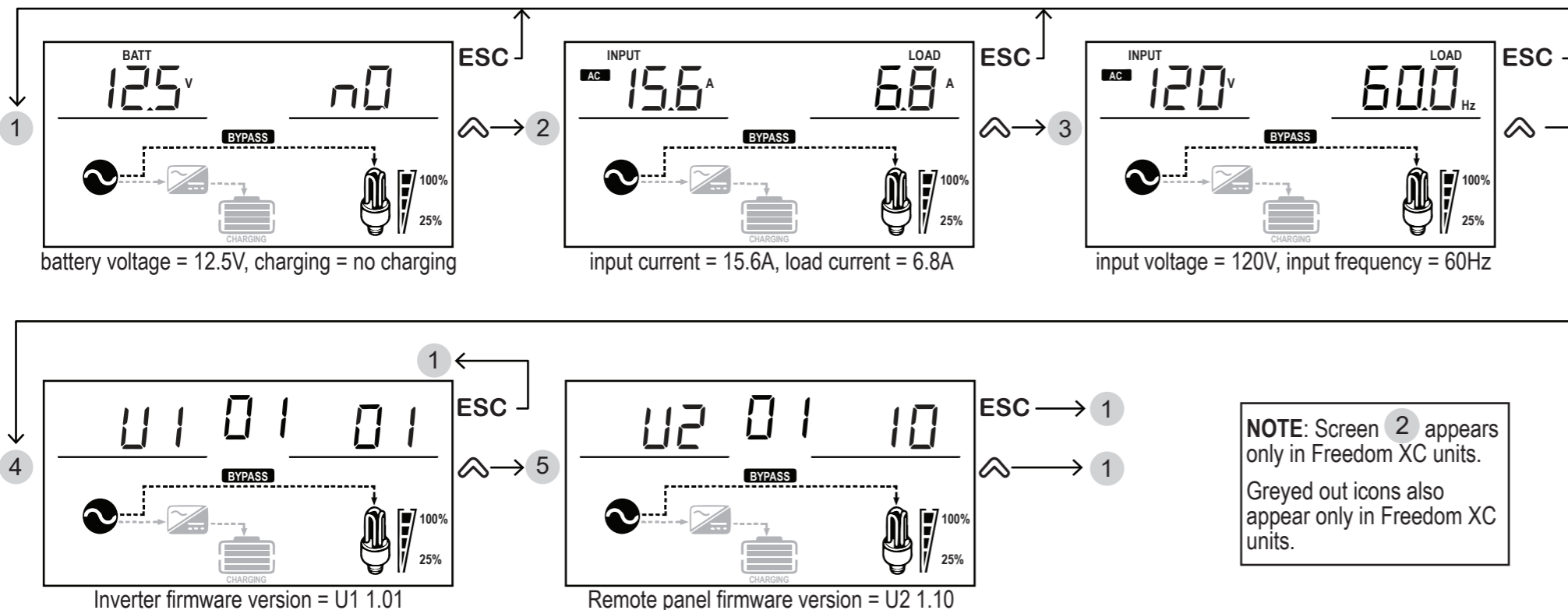

6

Adjusting Feature Settings

1. Press and hold the [OK] button for three seconds to enter the feature settings mode.
2. Press the scroll [↵] button to move through the different feature settings. **NOTE:** See the Freedom X / XC Owner's Guide for information on the individual settings.
3. Press the [OK] button to select a setting number and change its value.
4. Press the scroll [↵] button to change the value until you reach the desired value.
5. Press the [OK] button to confirm the change.
6. Repeat previous steps to set other feature settings.
7. Press [ESC] to exit the feature settings mode. **NOTE:** It may take a minute for the settings to take effect on the inverter unit.

7

Creating a Bluetooth Link with the Freedom X Remote Panel App

The Freedom X Remote Panel app (**FXC Control**) allows you to conveniently monitor and configure a Freedom X inverter (or a Freedom XC inverter/charger)^a with a compatible smart device^b using a Bluetooth connection.

1. Download and install the FXC Control app into a compatible Android or iOS smart device.



2. Turn on the Bluetooth enabled Freedom X Remote Panel by using the ON/OFF button on either its own front panel or the connected inverter's front panel.

3. Launch the FXC Control app on your smart device.

4. Turn on the smart device's Bluetooth through the Bluetooth toggle on the app. The app should now indicate that it is searching for devices.
5. On the Freedom X Remote Panel, press and hold the ESC button to enable Bluetooth pairing on the remote. Remote pairing can be observed by the two flashing horizontal lines underneath the left and right numbers.
6. When the app has detected the Bluetooth signal, it will display the connected inverter's serial number in the app. Click on the serial number to complete the pairing process.
7. To stop the Bluetooth connection, disable the smart device's Bluetooth connectivity.

^a List of compatible Freedom X/XC units:
 817-1000, 817-2000, 817-2000-21, 817-3000,
 817-1050, 817-2080, 818-2010, 818-3010, 806-1212

^b Compatible smart devices:
 iPhone or iPad running iOS 8 or higher
 Android phone or tablet running v8 or higher with Bluetooth
 Low Energy compatibility

A

Installing the Remote Panel Unit on the Wall

1. Place the template on the wall.
2. Mark the corners (or trace the dotted lines) of the recess outline on the wall.
3. Mark the two mounting holes for the two screws on the wall.
4. Remove the template from the wall.
5. Cut along the recess outline on the wall to make a hole for the remote panel's body.
6. Pre-drill the mounting holes appropriate to the mounting screws (not provided) that will be used.
7. Connect the 6-conductor com cable to the RJ12 ports on the inverter and remote panel.
8. Mount the remote panel unit on the wall.

Mounting Template

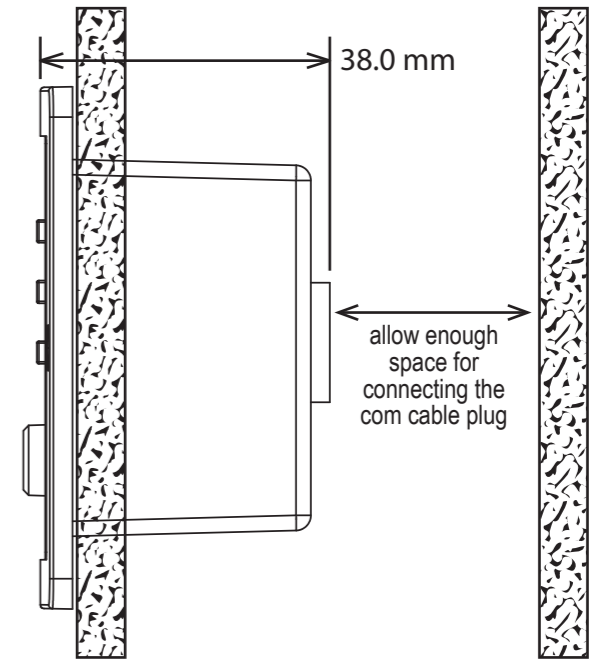
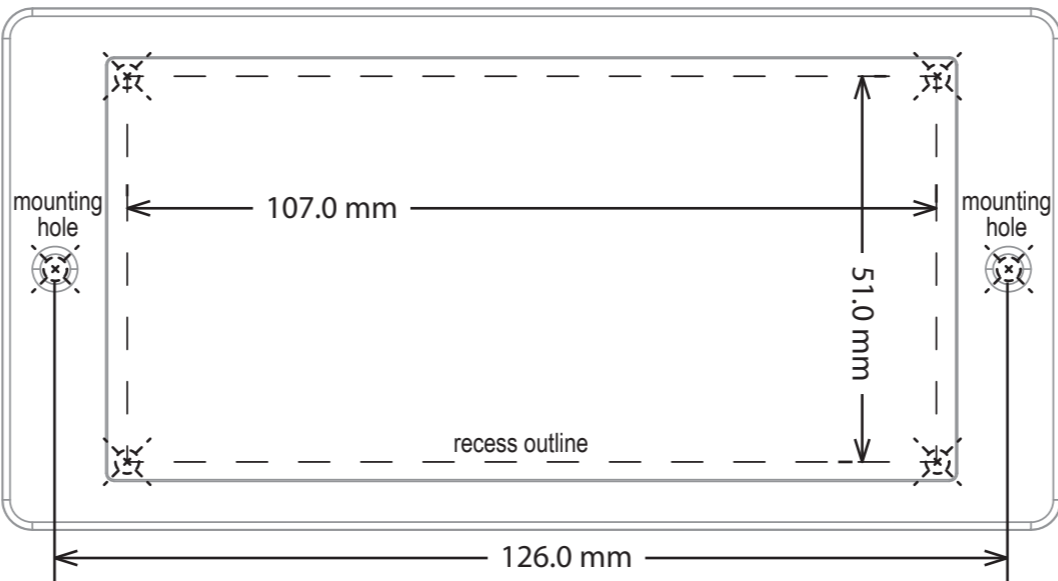

NOTE: Ensure the inside wall is free of obstructions, such as pipes, insulation, and electrical wiring. Ensure the recess depth is more than 50 mm.

B



Installing the Freedom X Remote Panel with a Wall Mount Adaptor

The Freedom X Remote Panel Wall Mount Adaptor (PN: 808-0819) allows the installation of the Freedom X Remote Panel onto an adaptor bezel which then fits over the existing wall panel opening of a Freedom 458 Basic Remote Panel.

- 1. Unmount the Freedom 458 Basic Remote Panel from the wall by removing the four screws securing it to the wall. Set aside the four screws.

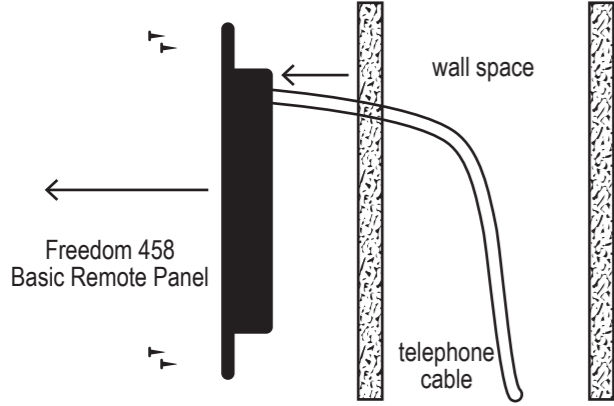

- 2. Detach the six-conductor telephone cable from the Freedom 458 Basic Remote Panel.
- 3. Install the Freedom X Remote Panel Wall Adaptor to the wall at the outer corners with the four screws in step 1. Alternatively, use optional counter-sink screws, if needed.

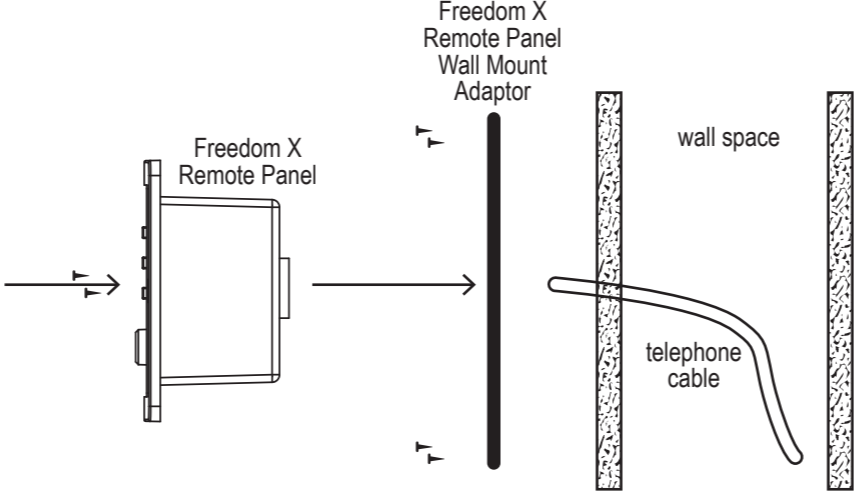

- 4. Take the Freedom X Remote Panel and attach the six-conductor telephone cable from the wall opening.
- 5. Mount the Freedom X Remote Panel to the Freedom X Remote Panel Wall Adaptor securing it with the two supplied mounting screws.
- 6. Complete the inverter installation and start up procedure in the Freedom X/XC Owner's Guide.