

WF-9800 Series

Deckmount Converter-Charger



THE HEARTBEAT OF TODAY'S RVs



EXPERT PRODUCT SUPPORT

TABLE OF CONTENTS

| | |
|-----------------------------------|----|
| SAFETY INFORMATION | 3 |
| GENERAL INFORMATION | |
| Reverse Battery Protection | 3 |
| Automatic Cooling Fan | 4 |
| Over-Temperature Protection | 4 |
| Electronic Current Limiting | 4 |
| Short Circuit Protection | 4 |
| CIRCUIT PROTECTION | |
| DC Fuses | 5 |
| OPERATIONAL FEATURES | |
| Three Stage Smart Charging | 5 |
| TROUBLESHOOTING INSTRUCTIONS | |
| Converter Output Voltage | 6 |
| Reverse Polarity Fuses | 7 |
| Troubleshooting Flow Chart | 8 |
| GENERAL COMPLIANCE INFORMATION | |
| Agency Listings | 8 |
| INSTALLATION INSTRUCTIONS | |
| Mounting the Enclosure | 9 |
| DC Connections | 10 |
| AC Connections | 10 |
| SPECIFICATIONS | 12 |
| WARRANTY INFORMATION | 13 |





| |
|---|
| ⚠ WARNING |
| RISK OF ELECTRICAL SHOCK Disconnect or isolate all power supplies before making electrical connections. More than one disconnection or isolation may be required to completely de-energize equipment. Contact with components carrying hazardous voltage can cause electric shock and may result in severe personal injury or death. |
| NOTICE |
| All wiring must conform to local, national, and regional regulations. Use copper conductors only for all wire connections. Do not exceed the electrical ratings for the WF-9800 Series Converter-Charger as this may cause equipment failure and/or electrical shock which may result in severe personal injury or death. |
| ⚠ CAUTION |
| EQUIPMENT SERVICING This product should be installed by an experienced certified technician. CAUTION and care must be taken when servicing this equipment. To prevent severe shock or electrocution, consult your servicing dealer. |
| ⚠ WARNING |
| SPARK HAZZARD This unit employs components that can produce arcs or sparks. To prevent fire or explosion, do not install in compartments containing batteries or flammable materials (LP gas). This product is NOT ignition protected. |
| ⚠ CAUTION |
| DO NOT OBSTRUCT VENTILLATION To prevent fire, DO NOT cover or obstruct enclosure ventilation openings. DO NOT mount unit in a zero-clearance compartment as overheating may result. For continued protection against risk of fire or electric shock, replace faulty DC fuses and AC breakers with ones of the same type and ratings as are installed. |
| ⚠ WARNING |
| BATTERY SYSTEM Use converter only on appropriate battery systems. Other usage may cause personal injury and damage. Consult all battery manufacturer's recommendations for additional safety information before use. |

GENERAL INFORMATION

WF-9800 Series Converter-Charger Safety Features

Reverse Battery Protection

The WF-9800 Series Converter-Chargers will charge the 12-volt house battery if installed. A battery does not have to be installed for WF-9800 Series Converter-Chargers operation. When a battery is installed, two reverse polarity fuses are installed to protect the converter circuitry. The fuses are located on the rear panel of the enclosure near the AC power cord (refer to Figure 1 below). This feature prevents permanent damage to the converter from a battery connected into the circuit backwards. In addition to protecting the converter-charger, the reverse polarity fuses are the main connection between the converter-charger and the DC fuse board of a distribution center.



Automatic Cooling Fan

The cooling fan in the WF-9800 Series Converter-Chargers is controlled by the current (Amperage) load attached to the converter, NOT by temperature. The on-board microprocessor increases fan speed as the total load increases and decreases fan speed as the load decreases.

Unlike traditional temperature-controlled fans, the load-controlled fan provides better component cooling by avoiding temperature spikes which can lead to premature component failure.

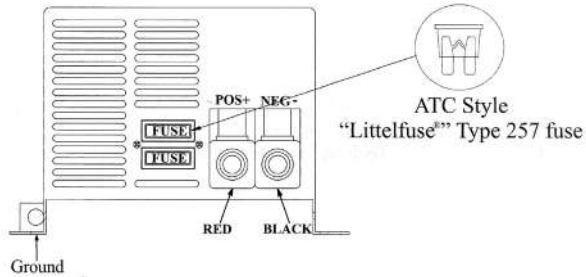

Figure 1

Over-Temperature Protection

If the internal temperature of the converter exceeds a critical point, it will shut down. This protects the unit from excessive heat that may damage sensitive components. The unit will restart once the temperature inside has dropped.

Electronic Current Limiting

In the event that the output current exceeds the maximum rating for the WF-9800 Series Converter-Charger, the output current will remain constant, but the output voltage will begin to drop. If this occurs, the unit will recover once loads are reduced.

Short-Circuit Protection

Should a short circuit occur in the RV, the WF-9800 Series Converter-Charger will drop the voltage output to zero volts. If the short-circuit condition is removed and no other fault conditions are detected, the converter will resume normal operation. However, short-circuit conditions are **dangerous**, and an RV will require inspection by a qualified service technician.



CIRCUIT PROTECTION

WF-9800 Series Converter-Charger Fuses

DC Fuses (12 Volts)

The DC fuse receptacle on the rear panel of the WF-9800 Series Converter-Charger has space for 1 (one) or 2 (two) Reverse Battery Protection fuses (see Figure 1 above). These fuses should be replaced with ATC or ATO automotive type fuses, such as Littelfuse type 257 or Bussmann type ATC. Each converter model requires a different Amperage value fuse as follows:

- WF-9835 - (1) 40A
- WF-9845 - (2) 30A
- WF-9855 - (2) 35A
- WF-9865 - (2) 40A
- WF-9875 - (2) 40A

OPERATIONAL FEATURES

Converter Operation Modes



Three-Stage Smart Charging

The three-stage “smart” charger continuously measures the battery voltage output and regulates the amount of charge using three modes of operation; Absorption, Bulk, and Float. See Figure 3 below.

The converter normally provides a constant target output voltage of 13.6 volts (nominal) to power all the branch circuits. However, it is current limited, and if the output (load) current reaches its maximum, the output voltage will drop as necessary to hold the converter’s maximum output current level (the amperage rating) without exceeding it.

If the output current reaches its maximum (normally caused by a discharged battery), this will cause the converter to go into Bulk Mode, which means the target output voltage will change to 14.4 volts and a timer will start. Although the converter is outputting 14.4 volts, you will not be able to read that on a voltmeter due to the voltage-current relationship. From the paragraph above, as load current increases, output voltage decreases. The actual output voltage will not rise until the load is reduced, which happens naturally as the battery charges or if 12-volt appliances are turned off.

Bulk Mode will be maintained until the current draw drops to approximately five amps, or until the timer reaches four hours (whichever happens first). Then the target output voltage is changed back to 13.6 volts for Absorption Mode. Lights that are powered from the output may change brightness slightly at that time.

After the output has been maintained at 13.6 volts (Absorption Mode) for 44 hours, the converter will change to Float Mode with an output of 13.2 volts. This output may then reset to Absorption Mode (13.6 volts) if power is interrupted, or to Bulk Mode (14.4 volts) if the output current limit is reached.

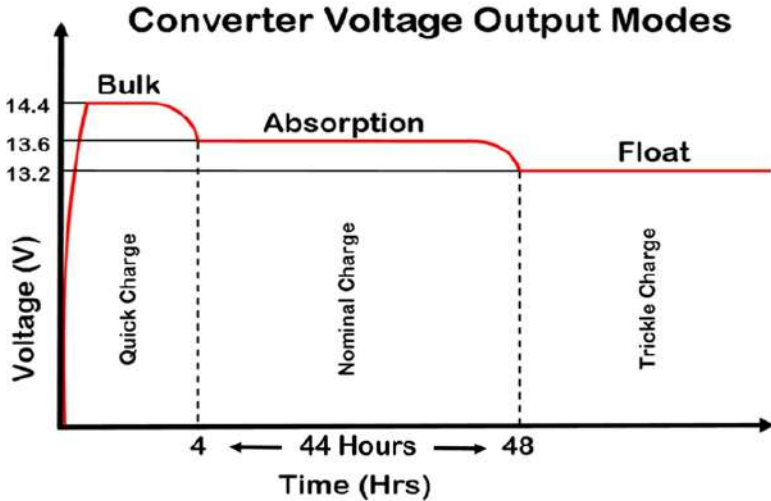

Figure 2

Note: The converter, while in Float Mode, will continue to supply a trickle charge to the battery. If the RV is in storage for any length of time, we recommend the battery and its fluid levels be checked every 3 weeks.

Note: For a detailed explanation of the charging modes, please refer to our publication “Theory of Operation”, document #AD-TD-0001-0.

TROUBLESHOOTING INSTRUCTIONS

Troubleshooting the WF-9800 Series Converter-Charger

CAUTION

EQUIPMENT SERVICING

This product should be installed by an experienced certified technician. CAUTION and care must be taken when servicing this equipment. To prevent severe shock or electrocution, consult your servicing dealer.

Converter Output Voltage

Before checking the WF-9800 Series Converter-Charger output voltage, disconnect the battery cables at the battery. Make sure the converter is plugged into a live AC source (105-130 Volts). Check the converter output voltage at the battery with a voltmeter. Place the meter probes on the disconnected battery cables; place the Positive (red) meter probe on the + Positive red battery wire and place the Negative (black) meter probe on the -Negative black wire on the battery cable (Figure 3). Be sure you have good connections at the cables. If the voltage reads 13.6 - 14.4 VDC (+/- 0.2) with no load, the converter is functioning properly.

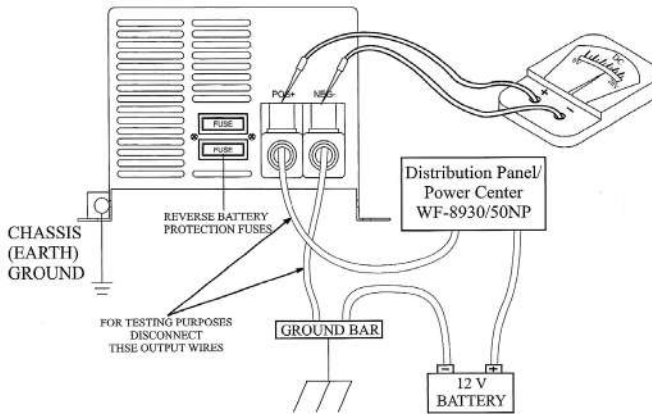

Figure 3

If the converter output voltage at the battery reads 0.0 VDC, or if the battery is not charging, check for an open inline fuse in the battery wire circuit. One may have been installed by the RV manufacturer. Also check for loose wiring connections.

Reverse Polarity Fuses

If there is no DC output coming from the WF-9800 Series Converter-Charger output lugs, first check the reverse polarity fuses on the rear panel. Then, visually inspect the fuses for any breaks in the fuse element. If no breaks are found, use a continuity tester to check for continuity. If the reverse polarity fuses are blown, it means the RV battery was accidentally connected in reverse, either at the battery or at the converter. Investigate the connections and reconnect the cables properly. Replace the fuse with the same type and amperage rating as the original.

IMPORTANT: These fuses protect the converter from damage if the RV battery is accidentally connected in reverse. A reversed battery connection, even if for only a second, will cause these fuses to blow.

If the above checks have been made but the converter output still reads 0.0 VDC, the converter is not functioning properly.



Troubleshooting Guide for the WF- 9800 Series Deck Mount

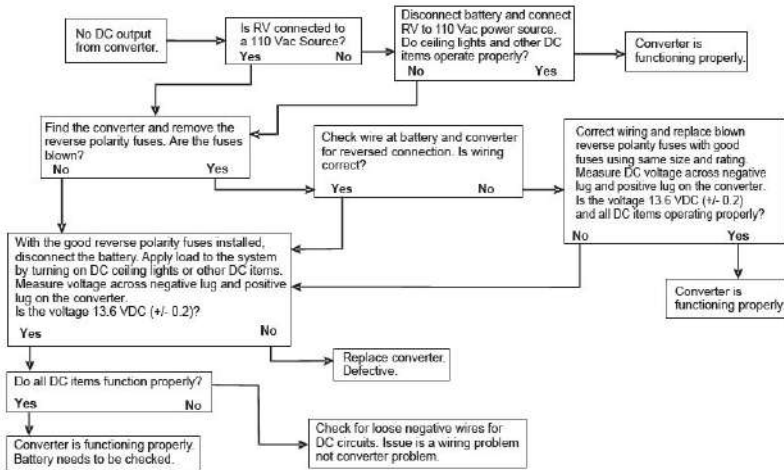

Figure 4

GENERAL COMPLIANCE INFORMATION

Agency Listings

UL

The WF-9800 Series Converter-Chargers are UL-Listed, and cUL-Listed (Canadian).

FCC Compliance Class B

NOTE: This equipment has been tested and found to comply with the limits for a Class B digital device, pursuant to Part 15 of the FCC Rules. These limits are designed to provide reasonable protection against harmful interference when the equipment is operated in a commercial environment. This equipment generates, uses, and can radiate radio frequency energy, and if not installed and used in accordance with the instruction manual, may cause harmful interference to radio communications. Operation of this equipment in a residential area is likely to cause harmful interference in which case the user will be required to correct the interference at his own expense.

INSTALLATION INSTRUCTIONS

Installing the WF-9800 Series Converter-Charger



Mounting the Enclosure

The WF-9800 Series Converter-Charger enclosure should be mounted in an accessible area such as a wall or in the side of a cabinet. Select a mounting location near the shore power and battery (batteries), in an area where the owner is unlikely to store items as this could reduce clearance requirements, obstruct ventilation openings and affect the performance of the converter (Figure 5).

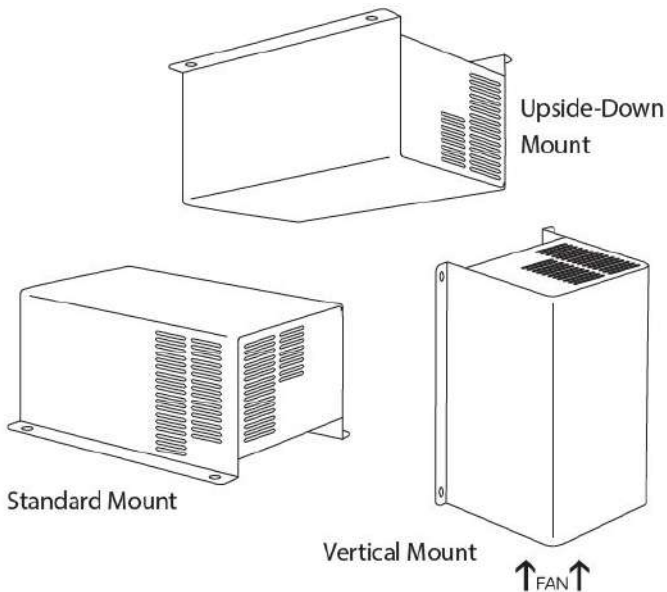

Figure 5

The location should be selected to prevent excessive heat, water, moisture, dust and dirt entering the unit installed. As a rule, allow two cubic feet of clear airspace and or any additional venting as necessary to prevent the unit from overheating. The front of the enclosure should not be obstructed to allow free air flow for the cooling fan (Figure 5).

An 8AWG copper conductor shall be used to bond the WF-9800 Series Converter-Charger to the vehicle frame.



DC Connections

Connect a Red 8 AWG wire to the POS+ lug on the distribution center's fuse board. Make sure this lug is torqued properly. In a similar fashion, connect a Black 8 AWG wire to the NEG- lug on the distribution center's fuse board.

A battery IS NOT required for converter operation. The battery works in conjunction with the converter to supply DC power to the RV. A battery is typically only necessary if you do a lot of dry camping or have slide-outs and/or a leveling system.

Deep-cycle batteries are recommended. They can be either of the Lead-Acid or the AGM type. The Amp hour (Ah) rating should be shown on the battery; for example, 120A. If you do a lot of dry camping, we recommend using a deep cycle battery rated at 100 Amp hours or more. The higher the Amp hour rating, the longer the battery will be able to deliver power when the converter is not plugged in. If you are plugged into shore power most of the time, a normal deep cycle battery will work.

When installing batteries, the batteries MUST be the same brand and type (preferably the same age as well). Adding more batteries will provide longer use of DC appliances when not on shore power. Due to the additional battery load, the converter's battery charging efficiency may be reduced. However, even in normal "Absorption Mode" (13.6 VDC range), the batteries are being charged, just at a slower rate.

NOTE: The converter will not work without AC input. You may notice that, when a battery is connected or reconnected to the converter's output, the onboard fan may energize for a few seconds. This is normal and is the converter's circuitry recognizing the battery voltage. You will notice the same occurrence when the converter is initially energized on Shore power.

WARNING

RISK OF ELECTRICAL SHOCK

Disconnect or isolate all power supplies before making electrical connections. More than one disconnection or isolation may be required to completely de-energize equipment. Contact with components carrying hazardous voltage can cause electric shock and may result in severe personal injury or death.

AC Connections

The WF-9800 Series Converter-Chargers receive power from the power cord on the opposite end of the enclosure from the DC lugs. The WF-9835, WF-9845 and WF-9855 have a standard 15 Amp plug.

The WF-9865 and WF-9875 have a 20 Amp plug due to the higher current required from the AC line to produce the high DC current output. The 20 Amp plug and corresponding receptacle are shown in Figure 6 below. The 20 Amp receptacle must be wired back to the fuse box using 12AWG wire minimum.

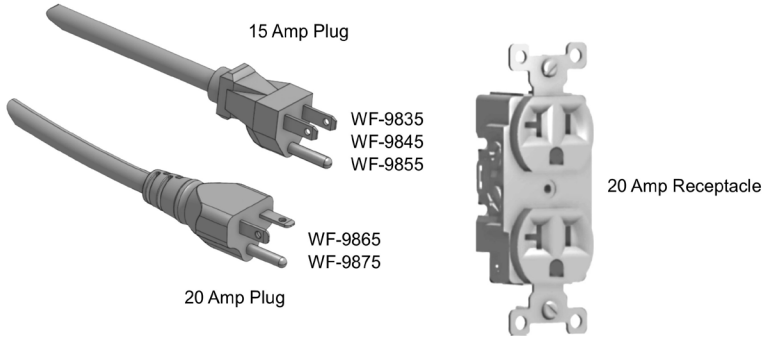

Figure 6

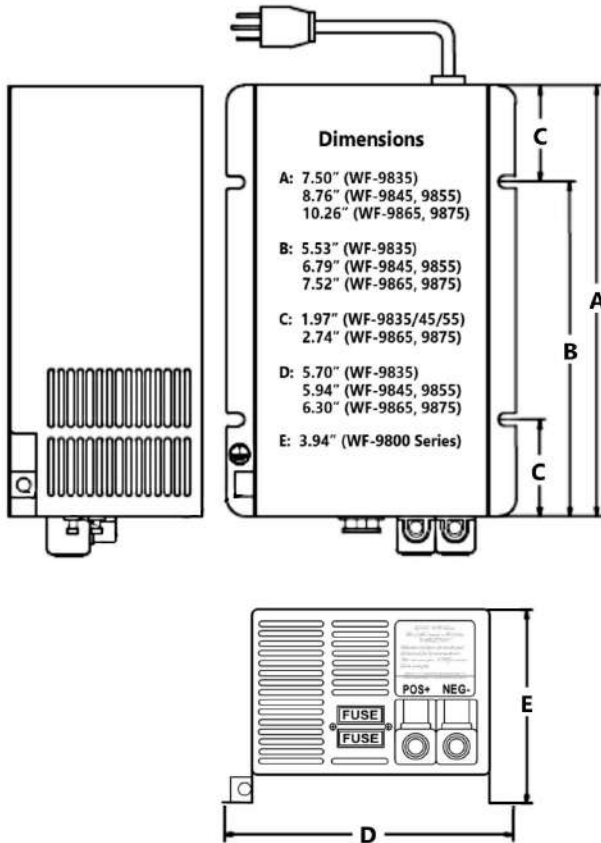

Figure 7



| WF-9800 Converter Specification | | | | | |
|---------------------------------|--|--|-------------------|---|--------------------|
| Model No. | WF-9835 | WF-9845 | WF-9855 | WF-9865 | WF-9875 |
| Converter Input Power: | | | | | |
| Voltage: | 105-130VAC | | | | |
| Frequency: | 60Hz | | | | |
| Max. input current @105Vac | 7A | 9A | 11A | 13A | 15A |
| Max Power | 600 watt | 770 watt | 940 watt | 1110 watt | 1280 watt |
| Converter Output Power | | | | | |
| Continuous power: | 475 watt | 610 watt | 750 watt | 880 watt | 1020 watt |
| Rated DC Output Voltage | 13.6V | | | | |
| Rated DC Current | 35A | 45A | 55A | 65A | 75A |
| Charging Control | Automatically controlled by microprocessor | | | | |
| Charging Modes | 3-stage Intelligent charge | | | | |
| Intelligent charge mode | Absorption - Bulk and Storage (Float) | | | | |
| Battery Adaptability | LA/AGM | | | | |
| Absorption charge voltage | 13.6V | | | | |
| Bulk charge voltage: (4 Hrs) | 14.4V | | | | |
| Storage charge voltage | 13.2V | | | | |
| Regulation | ±1% accuracy against input or load changes | | | | |
| Cooling Fan | Two speed according to the DC load Amperage | | | | |
| VA Efficiency: | > 80% (under 70% of load condition) | | | | |
| Protection: | | | | | |
| Overload | Current-limiting & shut down; auto recovery upon normal load | | | | |
| Short-circuit | Shut down & auto recovery upon return to normal | | | | |
| Over-temperature | Shut down & auto recovery upon return to normal | | | | |
| Battery reverse polarity | Protected by Fuse; same rated fuse replacement required | | | | |
| DC Distribution Board | | | | | |
| DC Battery Lugs: NEG-, POS+ | Lugs accept 2 to 14 AWG wire; Lug screws are 5/16" Allen Head | | | | |
| Mechanical: | | | | | |
| Dimensions: | 4 5/8"W x 4"H x 7 1/2"D / 117.5 mm W x 101.6 mm H x 190.5 mm D | 4 3/4"W x 4"H x 8 3/4"D / 120.7 mm W x 101.6 mm H x 222.3 mm D | | 5 1/8"W x 4"H x 10 1/4"D / 130 mm W x 101.6 mm H x 260.4 mm D | |
| Weight: | 4 lbs. / 1.8 kg | 5.25 lbs. / 2.4 kg | 5.5 lbs. / 2.5 kg | 6.25 lbs. / 2.8 kg | 6.75 lbs. / 3.1 kg |
| Environmental Condition: | 20 ~ 90% Non-condensing | | | | |
| Safety | UL458 certified; FCC Class B compliant | | | | |

Figure 8