

EM-15 & EM-20 Energy Management Switch



THE HEARTBEAT OF TODAY'S RVs

Model EM-15

Output: 15A
Input: 120 Vac,
60 Hz

Model EM-20

Output: 20A
Input: 120 Vac,
60 Hz

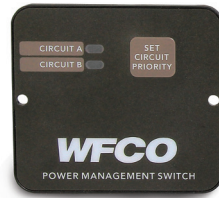

More Power for the RV Lifestyle

As RV designs get more and more like home life, so does the demand on their electrical infrastructure. RVers want to enjoy the comforts and luxuries of their home while on the road, and with this in mind, WFCO has developed the cost efficient EM-20 Energy Management Series Switches. The EM-15 for 15A applications, and the EM-20 for 20A applications.

Reliability. Vertically integrated, WFCO has total supply chain control, ensuring quality materials, parts and processes at each stage. Components are quality tested at critical manufacturing stages.

PRODUCT FEATURES

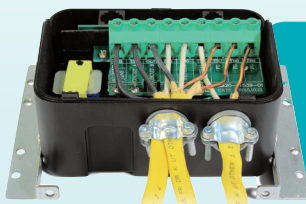

These features provide more safety and ease to technicians and RV owners.

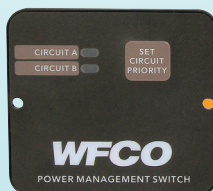

Remote control panel, available with the EM-20 so end-users can manually choose the branch circuit with priority operation.

- Smart Load Detection allows the device to effortlessly switch from two power loads to one load (the designated priority load) when total current exceeds a pre-determined trip level based on the model.
- The EM-20 can eliminate the need for 50A service with two air conditioners by operating one at a time.
- Designed to manage two mid to heavy loads, such as microwaves and fireplace/waterheaters, the EM-15 seamlessly switches power between appliances.
- The Energy Management Series Switches features three possible mounting positions for flexible design and quick installation: wall/floor mount, back of 8500 Series power center, or back of 8900 Series power center.

EM-15 & EM-20 Energy Management Switch

THE MOST FLEXIBLE WAY TO MANAGE ENERGY

All WFCO products are designed to better meet the needs of RV owners while also making the job simpler for the installer and production line. Both the EM-15 & EM-20 offer flexible mounting options, while the EM-20 also provides a number of unique features – like a remote panel for manual energy management and four power modes – that make it easy for RV owners to assign energy to the circuit they need at any particular time.

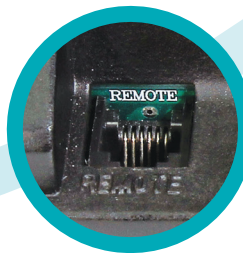

The EM-20 allows a simple remote control hook up for convenient end-user power management.

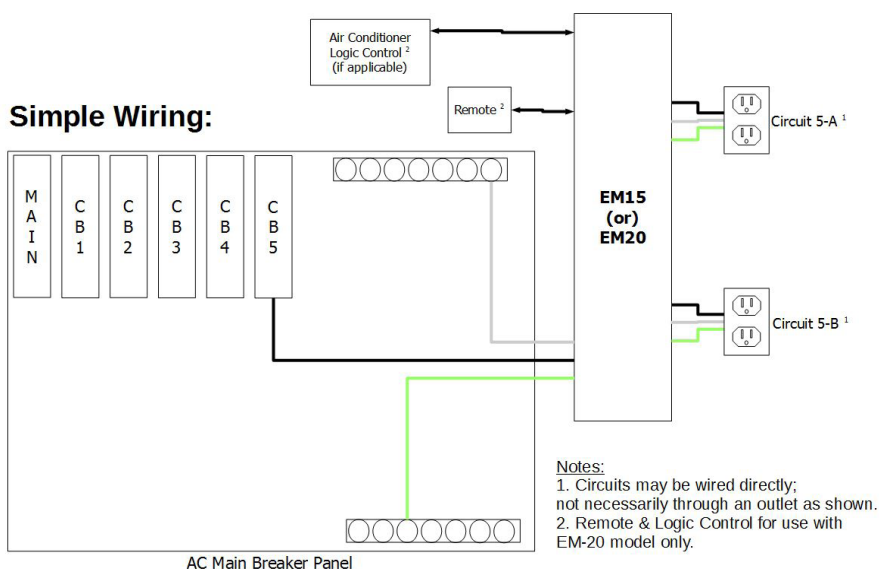

ENERGY MANAGEMENT SWITCH

SPECIFICATIONS	EM-15	EM-20
Power	120V / 60Hz	
Power Relay	2; Contact Rating: 30A/250Vac; Coil Rating: 12Vdc	
Logic Control Rating		2; SPDT Contact Rating: 3A/250Vac; Coil Rating: 12 Vdc
AC Connections	9P terminal block for 14AWG wire; suggested 7 in-lbs torque	9p terminal block for 12AWG wire; suggested 7 in-lbs torque
Remote Switch		12 ft. long wire and RJ11 connector; one switch to set circuit priority; 2 LEDs to indicate which circuit is priority
MECHANICAL:		
Enclosure:	Fire-retardant reinforced plastic	
Mounting:	Wall/floor mounting or mount directly to the back of WFCO Power Centers (8900 or 8500 Series)	
Dimension: L x W x H	5.04 x 4.41 x 2.9 inch / 128 x 112 x 73 mm	
Weight:	0.55 kgs / 1.21 lbs.	
Safety:	CETL / UL 916 + CSA C22.2 NO. 205	

Certifications: UL* and cUL* listed and FCC Class B compliant.
Specifications are subject to change without notice or obligation.

