

# 8 split phase system example

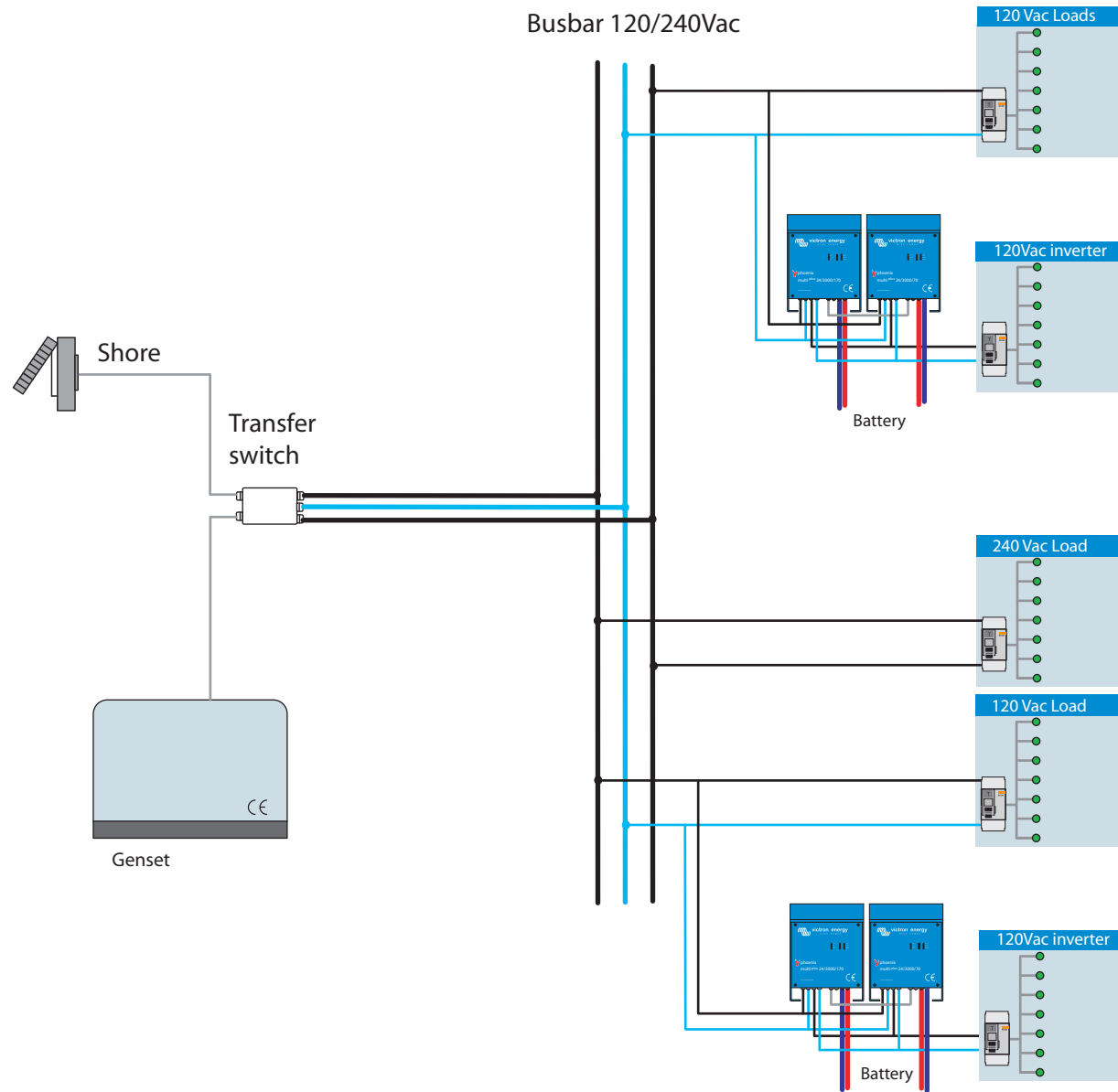

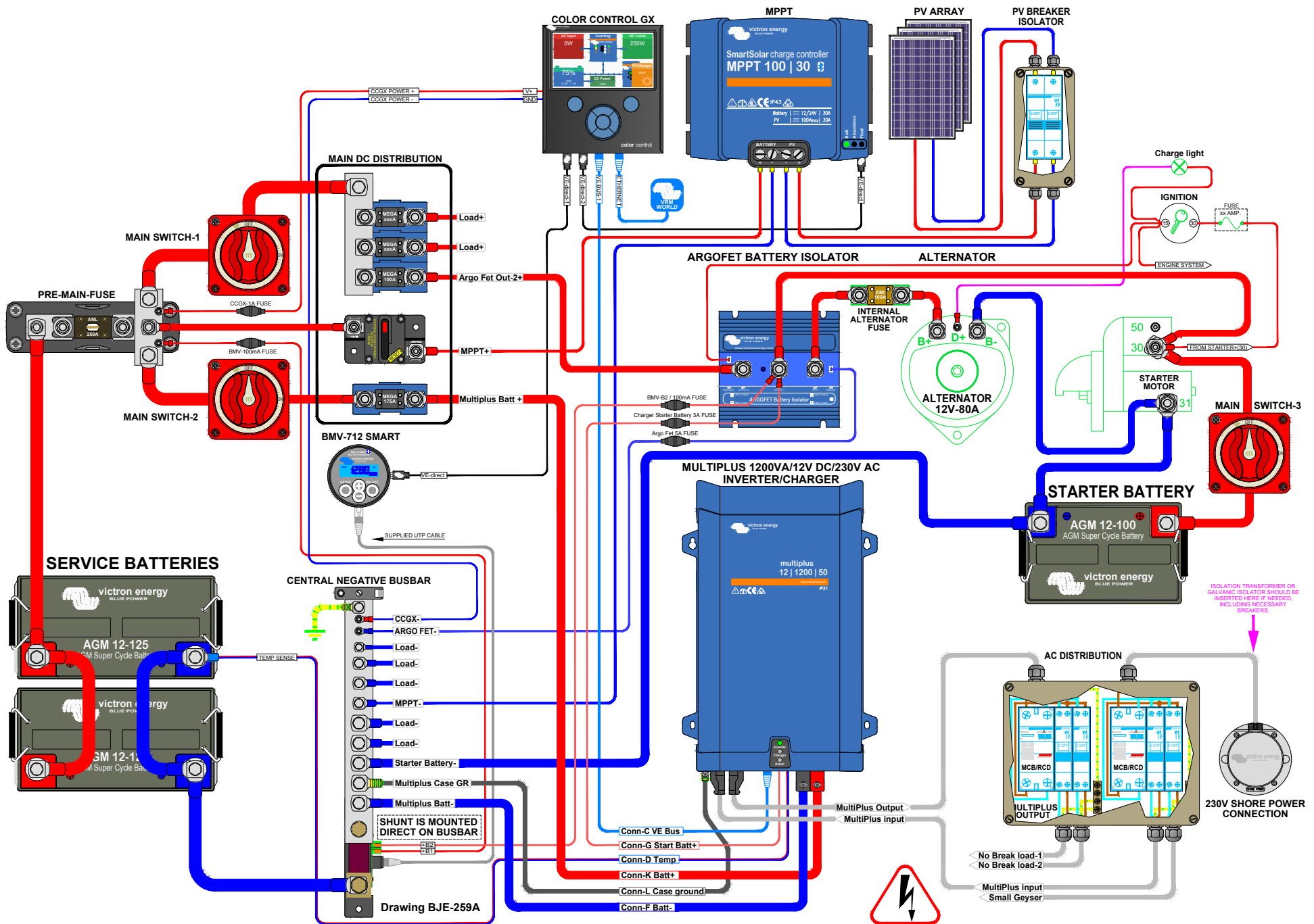

**Recommended AC Out cable/breaker size MultiPlus**  
 With Power assist the MultiPlus can add 1 kW to the output load when needed. Together with the adjustable 16A input this all adds up to the max sum of input and output current of 16+4.3=20.3A. An Earth leakage with breaker or a combination MCB/RCD must be installed on the output. Cable size must be adjusted accordingly.

**Recommended DC cable/fuse size MultiPlus**  
 0-5 m cable length: 35Sqmm  
 Cable length stands for the total distance between the battery connections plus and minus and the MultiPlus connections! Recommendations are without other loads in the system and these also should be taken into account for proper main battery, main fuse & main switch cables! INTERNAL Fuse size should be 200A.

**Recommended AC In cable/breaker size MultiPlus**  
 AC IN must be protected by a circuit breaker rated at 16A max or less. This depends heavily on the size of the connected power source. The input current must be adjusted to fit the size of the connected power source. The breaker and cable size for AC IN should be adjusted accordingly.

**WARNING**  
 230 VOLT IS EXTREMELY HAZARDOUS DO NOT TOUCH ANY LIVE WIRED PARTS OF THE INSTALLATION! WHEN IN DOUBT, ALWAYS CONSULT YOUR VICTRON DEALER!

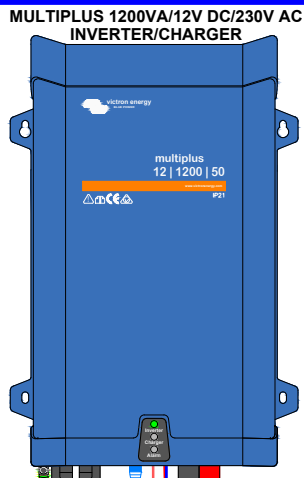
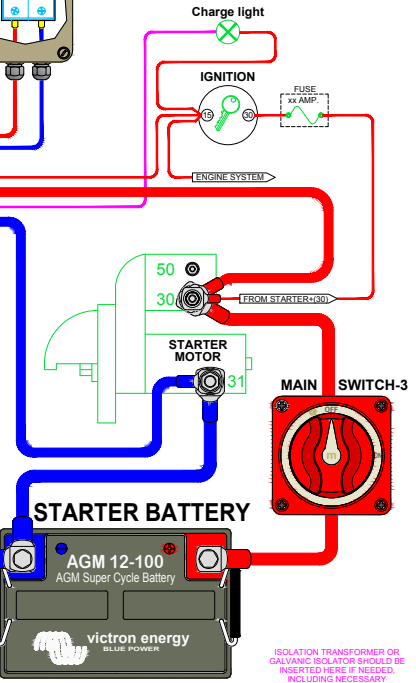
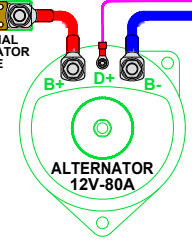
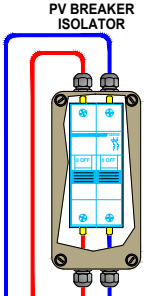
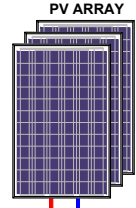
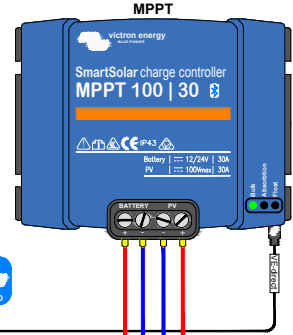
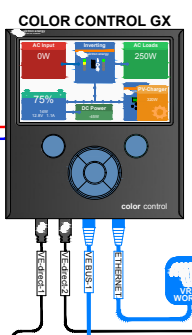
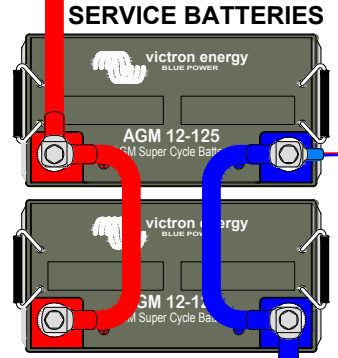
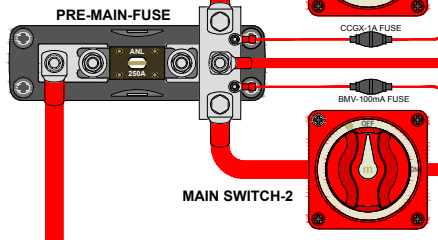
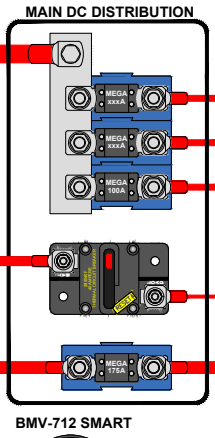
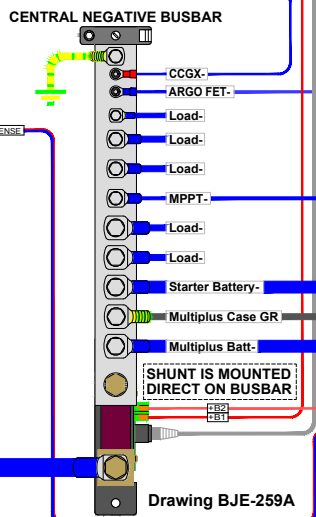
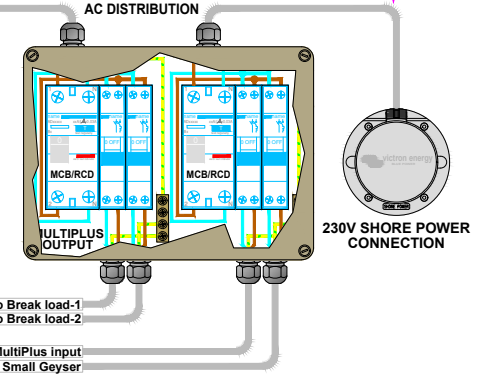

# Vehicle system

schematic with lithium

