

Argo Diode Battery Isolators



Argo Diode Isolator
120-2AC



Argo Diode Isolator
140-3AC

Diode battery isolators allow simultaneous charging of two or more batteries from one alternator, without connecting the batteries together. Discharging the accessory battery for example will not result in also discharging the starter battery.

The Argo Battery Isolators feature a low voltage drop thanks to the use of Schottky diodes: at low current the voltage drop is approximately 0,3 V and at the rated output approximately 0,45 V. All models are fitted with a compensation diode that can be used to slightly increase the output voltage of the alternator. This compensates for the voltage drop over the diodes in the isolator.

Please see our book 'Energy Unlimited' or ask for specialist advice when installing a diode isolator. Simply inserting the isolator in the cabling between the alternator and the batteries will slightly reduce charge voltage. The result can be that batteries are not charged to the full 100% and age prematurely.

Alternator energize input

Some alternators need DC voltage on the B+ output to start charging. Obviously, DC will be present when the alternator is directly connected to a battery. Inserting a Diode or FET splitter will however prevent any return voltage/current from the batteries to the B+, and the alternator will not start.

The new 'AC' diode isolators feature a special current limited energize input that will power the B+ when the engine run/stop switch is closed.

Argo Diode Battery Isolator	80-2SC	80-2AC	100-3AC	120-2AC	140-3AC	160-2AC	180-3AC
Maximum charge current (A)	80	80	100	120	140	160	180
Maximum alternator current (A)	80	80	100	120	140	160	180
Number of batteries	2	2	3	2	3	2	3
Alternator Energize Input	no	yes	yes	yes	yes	yes	yes
Connection	M6 Studs	M6 Studs	M6 Studs	M8 Studs	M8 Studs	M8 Studs	M8 Studs
Compensation diode and Energize connection	6,3 mm Faston	6,3 mm Faston	6,3 mm Faston	6,3 mm Faston	6,3 mm Faston	6,3 mm Faston	6,3 mm Faston
Weight kg (lbs)	0,5 (1.3)	0,6 (1.3)	0,8 (1.8)	0,8 (1.8)	1,1 (2.5)	1,1 (2.5)	1,5 (3.3)
Dimensions h x w x d in mm (h x w x d in inches)	60 x 120 x 75 (2.4 x 4.7 x 3.0)	60 x 120 x 90 (2.4 x 4.7 x 3.9)	60 x 120 x 115 (2.4 x 4.7 x 4.5)	60 x 120 x 115 (2.4 x 4.7 x 4.5)	60 x 120 x 150 (2.4 x 4.7 x 5.9)	60 x 120 x 150 (2.4 x 4.7 x 5.9)	60 x 120 x 200 (2.4 x 4.7 x 7.9)

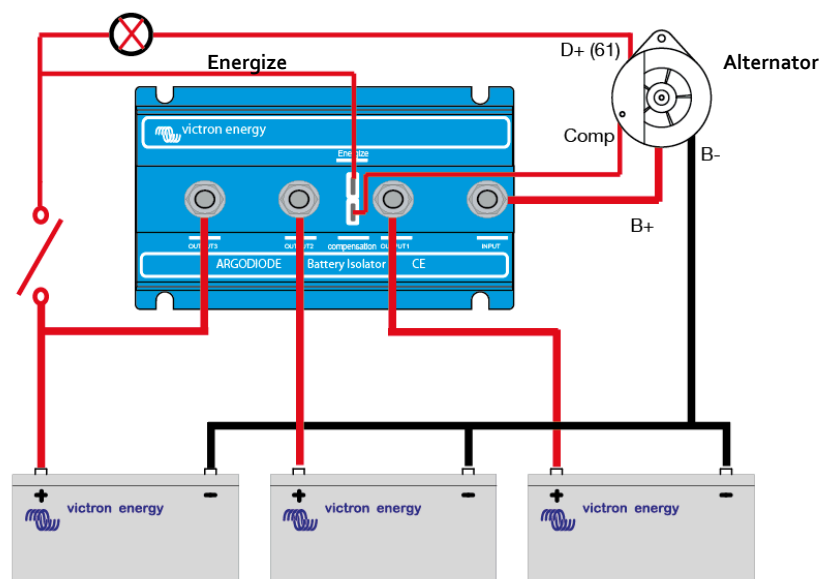

Oceanvolt teams up with Victron Energy

Press release Almere, 21 November 2013

The Finnish electric propulsion specialist Oceanvolt enters to a two-way relationship with Victron Energy.

The two companies will integrate their products to work as a unified system, which will form the base of Oceanvolts SEA® (Silent Electric Autonomy) concept. Oceanvolt SEA® system enables among other things running your A/C and other appliances without using your generator by converting the electricity from the propulsion system battery into 220VAC.

Oceanvolt will offer it's customers systems which use Victron Energy's charger/inverters, solar charger controllers and other electric components together with it's propulsion system. Oceanvolts electric propulsion systems have already been installed in over 50 customer boats.

Both parties of the agreement seem pleased. "Victron Energy's products perfectly compliments our propulsion system and together they offer our customers the comforts of home while at sea," says CEO of Oceanvolt, Timo Jaakkola.

"The Oceanvolt system impressed us. It is a mature and finished system. With this partnership our customers can offer an electric propulsion system which works as a part of a boats existing electrical network", says Victron Energy's Managing Director, Matthijs Vader.