

ARGO DIODE Battery Isolator 80-2SC with voltage compensating diode

ENGLISH

Diode battery isolators allow simultaneous charging of two or more batteries from one alternator, without connecting the batteries together. Discharging the accessory battery for example will not result in also discharging the starter battery.

The Argo Diode battery isolators feature a low voltage drop thanks to the use of Schottky diodes: at low current the voltage drop is approximately 0,3 V and at the rated output approximately 0,45 V.

Warning: hot surface, mount the Argo Diode on non-flammable surface only!

Compensation diode

All models are fitted with a compensation diode that can be used to slightly increase the output voltage of the alternator. This compensates for the voltage drop over the diodes in the isolator.

Care should be taken however to keep cable lengths short and of sufficient cross section.

Example:

When a current of 100 A flows through a cable of 50 mm² cross section (AWG 0) and 10 m length (30 ft), the voltage drop over the cable will be 0,26 Volt. Similarly a current of 50 A through a cable of 10 mm² cross section (AWG 7) and 5 m length (15 ft) will result in a voltage drop of 0,35 Volt!

Installation (see figure below)

1. Always disconnect the battery minus cables before making alterations to the electrical system.
2. Connect the positive output of the supplying source (alternator) to the input of the battery isolator.
3. Connect the positive connection of the battery sets to output 1, 2 and (optional) 3 respectively.
4. Optional: connect the voltage sense of the alternator to the compensation output of the ArgoDiode splitter.
5. Connect the negative poles of the battery sets to the common negative bus bar.

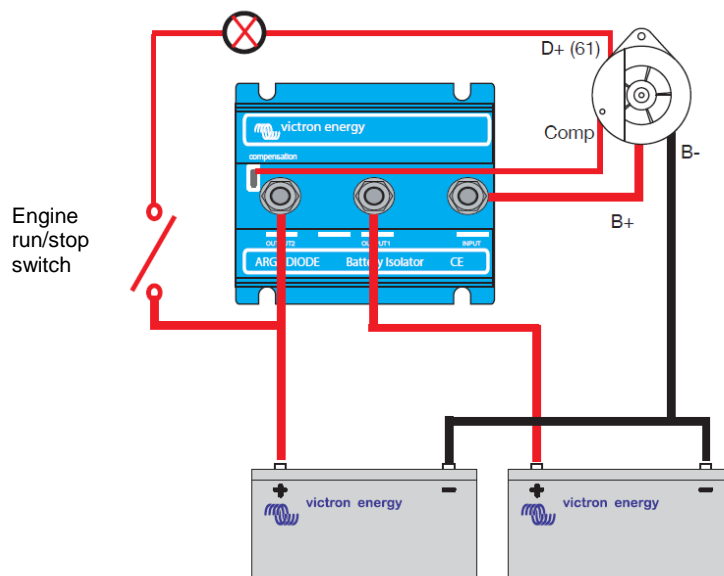

ARGO DIODE Battery Isolator with voltage compensating diode and alternator energize input

ENGLISH

Diode battery isolators allow simultaneous charging of two or more batteries from one alternator, without connecting the batteries together. Discharging the accessory battery for example will not result in also discharging the starter battery.

The ArgoDiode battery isolators feature a low voltage drop thanks to the use of Schottky diodes: at low current the voltage drop is approximately 0,3 V and at the rated output approximately 0,45 V.

Warning: hot surface, mount the Argo Diode on non-flammable surface only!

Compensation diode

All models are fitted with a compensation diode that can be used to slightly increase the output voltage of the alternator. This compensates for the voltage drop over the diodes in the isolator.

Care should be taken however to keep cable lengths short and of sufficient cross section.

Example:

When a current of 100 A flows through a cable of 50 mm² cross section (AWG 0) and 10 m length (30 ft), the voltage drop over the cable will be 0,26 Volt. Similarly a current of 50 A through a cable of 10 mm² cross section (AWG 7) and 5 m length (15 ft) will result in a voltage drop of 0,35 Volt!

Alternator energize input

Some alternators need DC voltage on the B+ output to start charging. Obviously, DC will be present when the alternator is directly connected to a battery. Inserting a Diode or FET splitter will however prevent any return voltage/current from the batteries to the B+, and the alternator will not start.

The new ArgoDiode isolators have a special current limited energize input that will power the B+ when the engine run/stop switch is closed.

Installation (see figure below)

1. Always disconnect the battery minus cables before making alterations to the electrical system.
2. Connect the positive output of the supplying source (alternator) to the input of the battery isolator.
3. Connect the positive connection of the battery sets to output 1, 2 and (optional) 3 respectively.
4. Optional: connect the 'Energize' blade terminal to the engine run/stop switch. Minimum cable cross section: 2,5 mm².
5. Optional: connect the voltage sense of the alternator to the compensation output of the ArgoDiode splitter.
6. Connect the negative poles of the battery sets to the common negative bus bar.

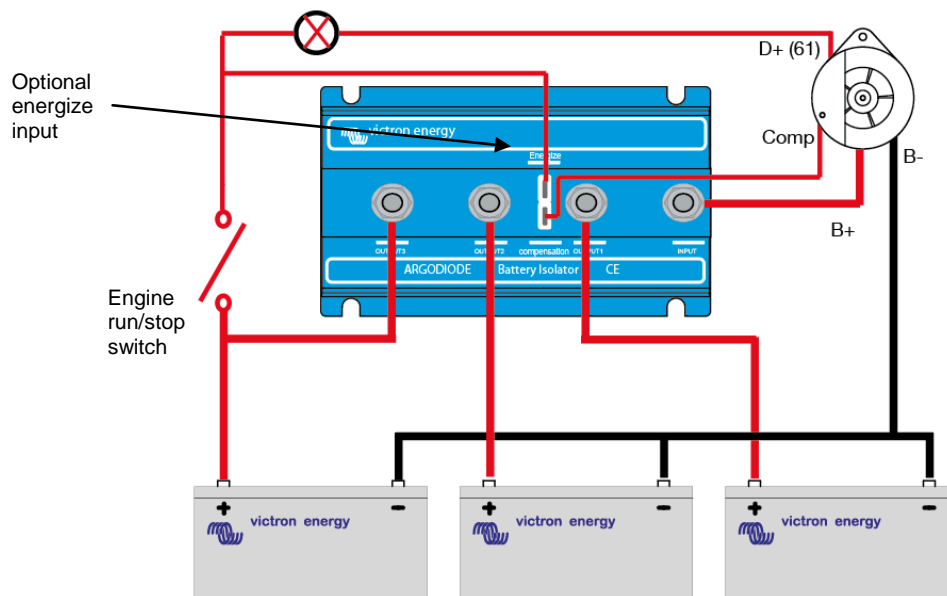

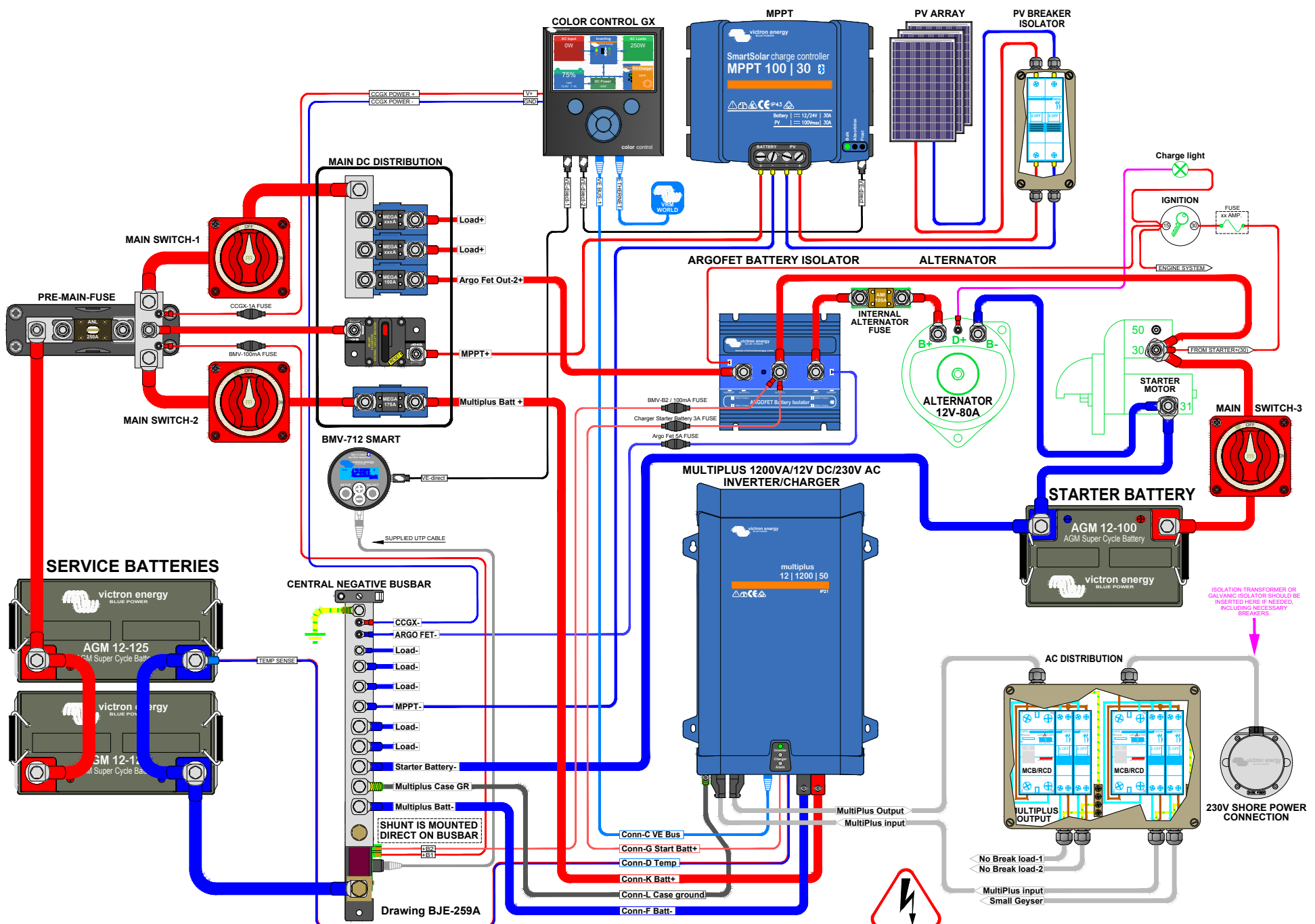

Recommended AC Out cable/breaker size MultiPlus
 With Power assist the MultiPlus can add 1 kW to the output load when needed. Together with the adjustable 16A input this all adds up to the max sum of input and output current of 16+4,3=20.3A. An Earth leakage with breaker or a combination MCB/RCD must be installed on the output. Cable size must be adjusted accordingly.

Recommended DC cable/fuse size MultiPlus
 0-5 m cable length: 35SQmm
 Cable length stands for the total distance between the battery connections plus and minus and the MultiPlus connections! Recommendations are without other loads in the system and these also should be taken into account for proper main battery, main fuse & main switch cables!
 INTERNAL Fuse size should be 200A.

Recommended AC in cable/breaker size MultiPlus
 AC IN must be protected by a circuit breaker rated at 16A max or less. This depends heavily on the size of the connected power source. The input current must be adjusted to fit the size of the connected power source.
 The breaker and cable size for AC IN should be adjusted accordingly.

WARNING
 230 VOLT IS EXTREMELY HAZARDOUS DO NOT TOUCH ANY LIVE WIRED PARTS OF THE INSTALLATION! WHEN IN DOUBT, ALWAYS CONSULT YOUR VICTRON DEALER!