

060-0600

Motor Home Entrance

Door Hardware

060-0650 Dead Bolt Option



DESIGNED FOR:

- Motor home entrance doors with thickness of 1.390" to 1.600". (Different inside plates are required to facilitate range of door thicknesses. Please identify when inquiring.)
- Fifth-wheel trailers, pull-type trailers and slide-in campers
- Doors requiring resistance to water and dirt infiltration
- Universal applications--either right or left handed



060-0600 Motor Home Entrance Door Hardware 060-0650 Dead Bolt Option

FEATURES/BENEFITS:

- Paddle can be locked before door is shut
- Paddle is rigid when locked
- Automotive styling
- Comfortable finger access
- Inside assist for easy closing
- Serviceable shuttered key cylinder
- Built-in dead bolt eliminates the need for an add-on residential type dead bolt
- Dead bolt locks into the fully extended position for true dead bolt functioning (060-0650)

AVAILABLE:

- With optional built-in dead bolt (060-0650)
- Master keyed paddle keycylinder. Non-master keyed dead bolt

MATERIAL:

- Housing, inside plates, paddles, plunger bolt and certain lock actuating components: die cast zinc alloy
- Strike plate: heat treated and zinc plated steel

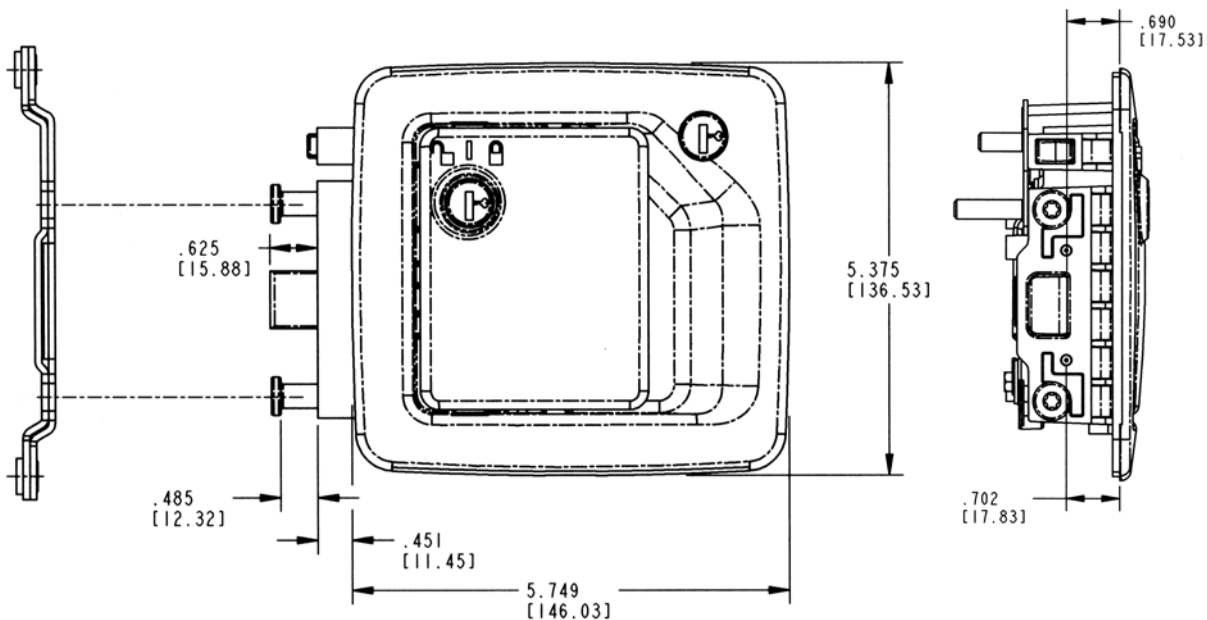

FINISH:

- Black powder coated
- Copper-nickel-chrome plated

INSTALLATION

- #10-24 UNC mounting screws (not included). Recommended torque 10 in./lbs. (1.1 N-m) 1/4-20 UNC grade 5-type fasteners for strike plate installation recommended
- Supplied with gasket already applied under recess in housing flange
- Sandwich mount installation does not require any linkage rods

Meets FMVSS 206 load requirements and may be used in FMVSS 206 applications pending TriMark application approval.

Individual part dimensions are for reference only. Refer to individual part drawings for complete dimensions, specifications, and installation procedures. Engineering assistance and application drawings are available.

