



**OVER 35 YEARS OF INNOVATION, QUALITY, SAFETY.
IMPORTANT OWNER-OPERATOR INSTALLATION INSTRUCTIONS**

BASEMENT GLOWSTEP

A7510- POWDERCOATED

A7513- ALUMINUM FINISH

**FOR CAMPERS WITH
BASEMENT STORAGE & STEP BUMPER**

Thank you for the purchase of this Basement GlowStep system. Please read this manual thoroughly as there are particular instructions that must be adhered to for proper installation, use, and storage.

Your Basement GlowStep is comprised of a GlowStep, Hinge brackets and assorted fasteners for installation. The Basement GlowStep is designed to give you an extra step up for those that have a large basement storage and bumper. Because of the large gap between the bumper and the threshold of the door, we designed the Basement GlowStep to offer an easier and safer step into and out of the camper. The Basement GlowStep can be locked into its “In-use” Position with supplied Ring Pin 1/4” and Hitch Pin Clip and can be quickly collapsed for access to the basement storage. Slide the Ring Pin 1/4” and Hitch Pin Clip into the designated holes in the rearward hinge brackets for storage when not in use. Pair this Basement GlowStep with a GlowGuide and the GlowStep Scissor Steps and have the ease of use; stability and the security of having the best step and handrail system on the market.

BASEMENT GLOWSTEP INVENTORY

- | | |
|---------------------------------|---------------------------|
| 4- HEX BOLT 3/8”-16 X 1-1/4” SS | 4- FLAT WASHER 3/8” SS |
| 2- RING PIN 1/4” | 1- BOLT FISHER 3/8” X 48” |
| 4- HEX NUT 3/8”-16 SS | 2- HITCH PIN CLIP |
| 4- LOCK WASHER 3/8” SS | |

*** IMPORTANT ***

This step kit requires a 8" x 24" foot print on the bumper or other mounting surface.

WEIGHT LIMIT: 325 LBS(147kg)

INSTALLATION INSTRUCTIONS FOR BUMPER MOUNTING

1. Set the Basement GlowStep in place on top of the bumper. Make sure there is no interference while in working position and the collapsed position.
2. Drill one hole, Then use the *BOLT FISHER 3/8" X 48" to pull one HEX BOLT 3/8"-16 X 1-1/4" SS, with one LOCK WASHER 3/8" SS through the bumper, Basement GlowStep Bracket and previous hole that was drilled. Hand tighten with one FLAT WASHER 3/8" SS and one HEX NUT 03/8"-16 SS. Repeat on other three holes.
3. Tighten the fasteners to 20 FT Lbs.(27nm) with a torque wrench.

To place the step into working position, hold the step in the upright position and attach the arched locking bar to the outside Hinge link with a RING PIN 1/4", and a HITCH PIN CLIP and clip into place.

To place the step into the collapsed position, Remove the RING PIN 1/4", and a HITCH PIN CLIP. Repeat on opposite side.

Side view of the Basement GlowStep in the Collapsed position

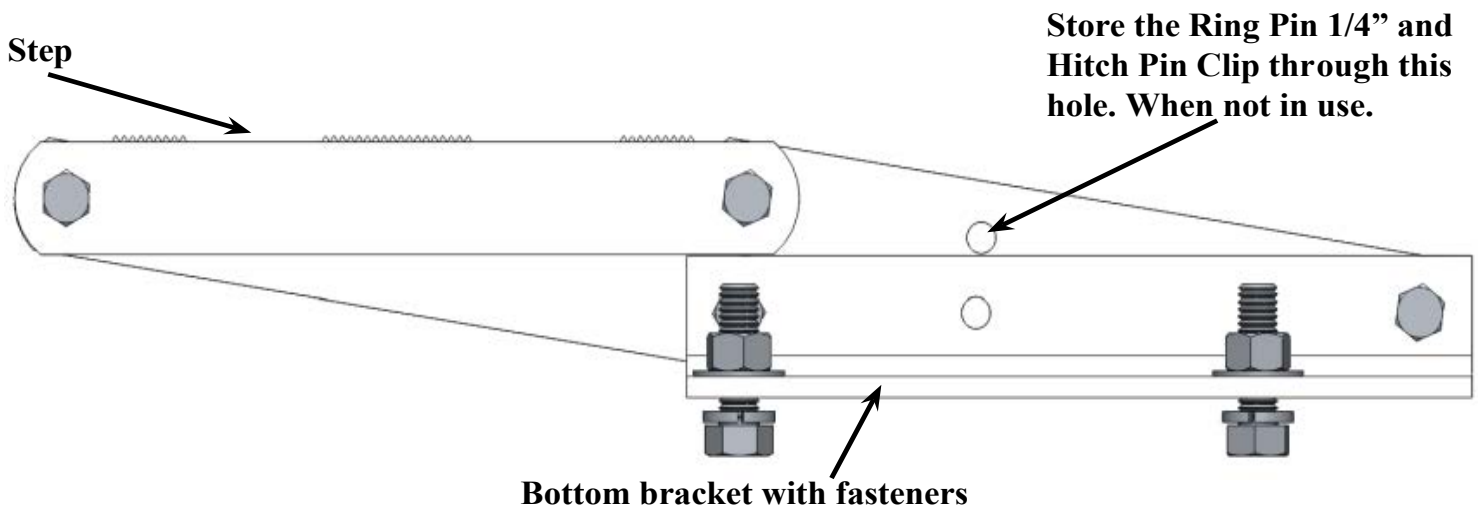

Exploded view of fasteners installed in Basement GlowStep on Bumper

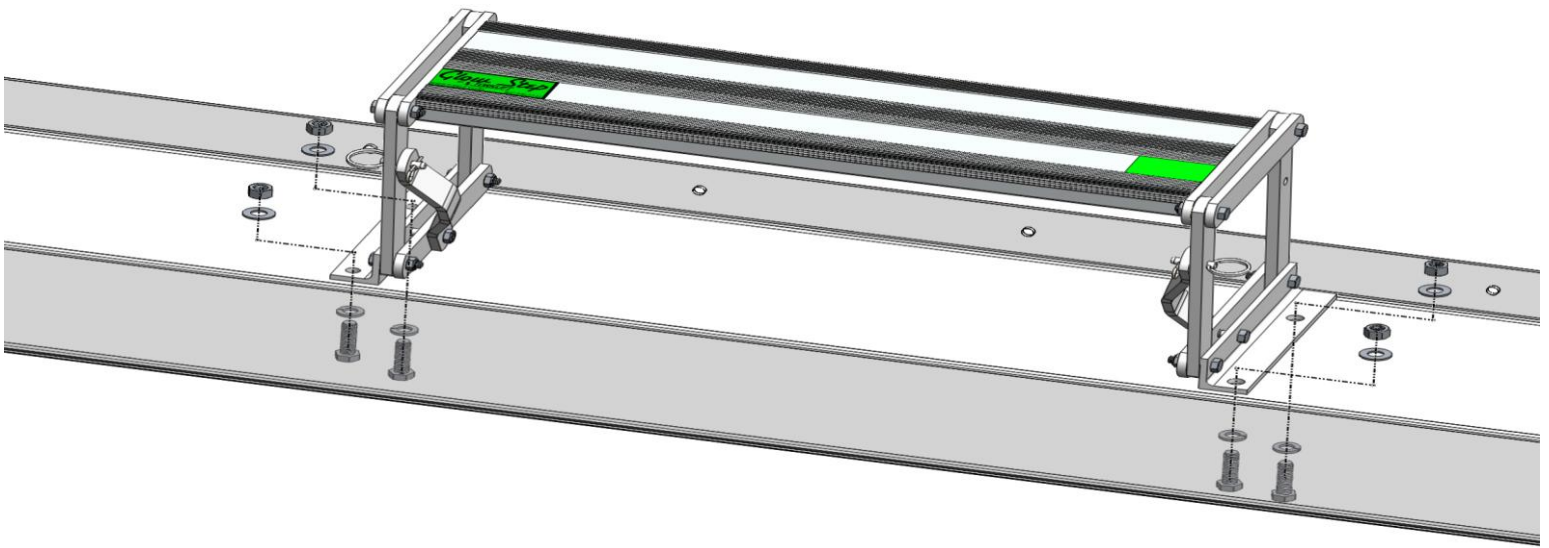

Collapsed angle view of Basement GlowStep

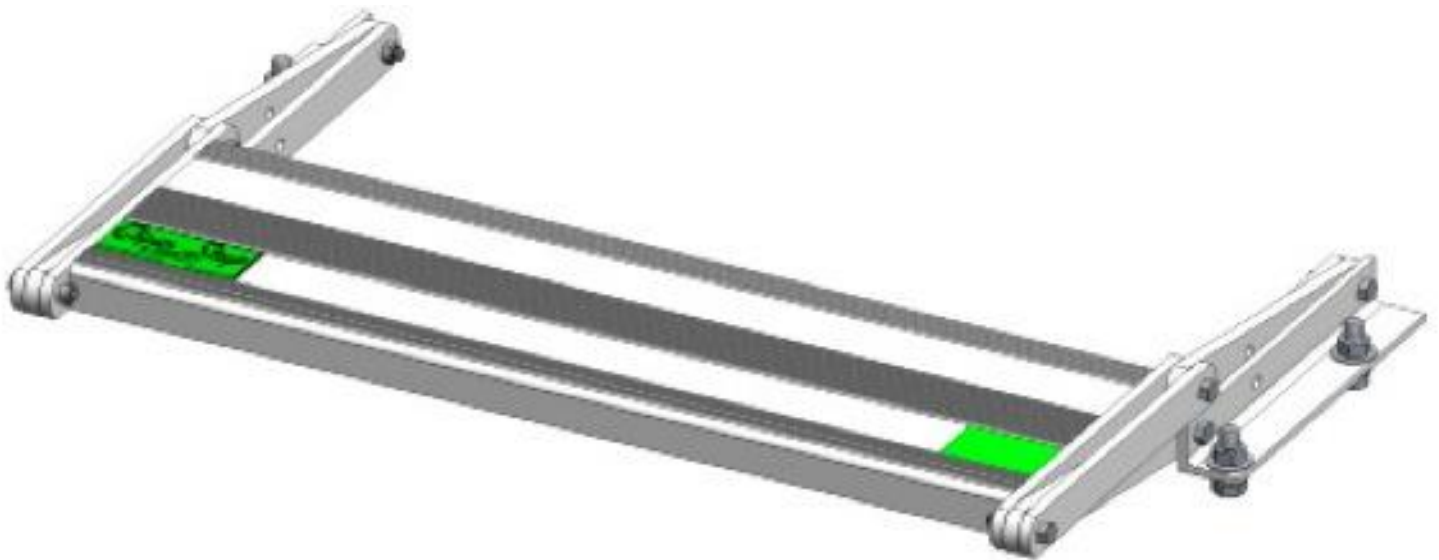

In-Use angle view of Basement GlowStep

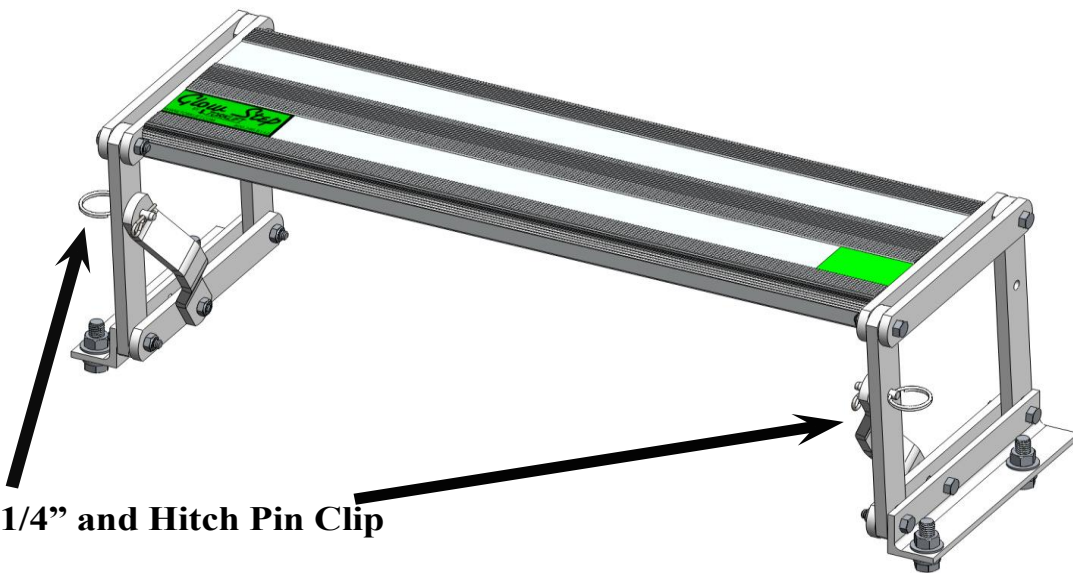

Ring Pin 1/4" and Hitch Pin Clip

TORKLIFT'S BOLT FISHING GUIDE

Your guide to understanding the installation of our frame mounted tie downs.

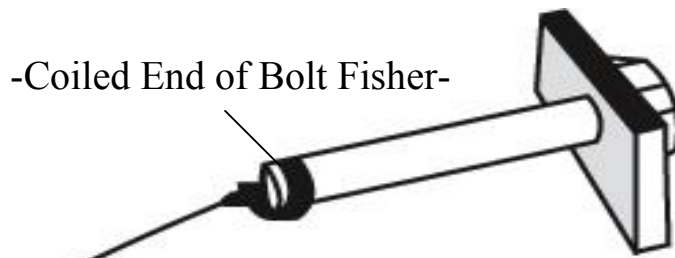

Note: The hardware may vary as to what is being fished along with the bolt. In this instance a 1" X 2" plate washer is being fished along with the hex bolt. Different applications may require fishing through various star washers and flat washers for example.

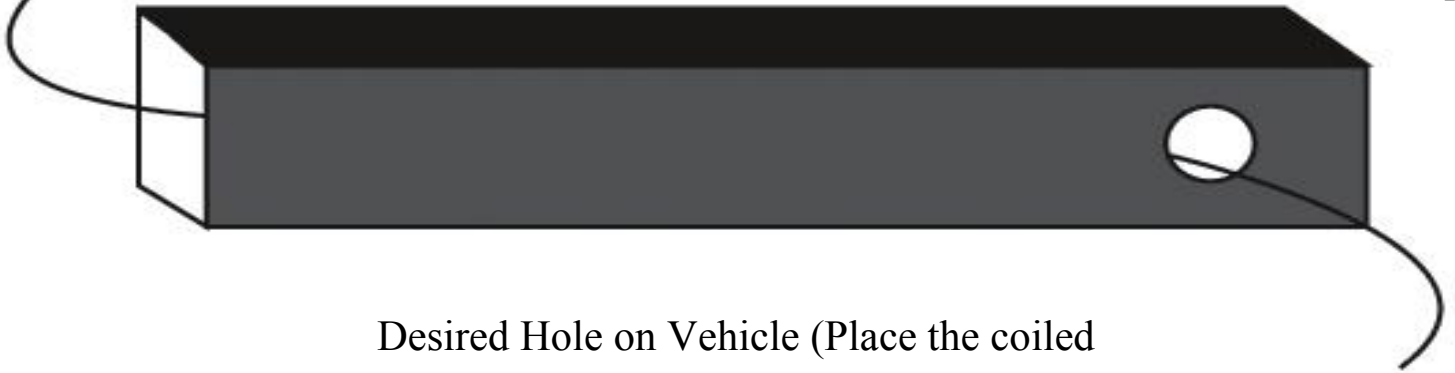

Desired Hole on Vehicle (Place the coiled end of the bolt fisher through this hole).

This side of the Bolt Fisher should come out of a hole where the required hardware (for example 1" X 2" plate washer) can pass through.



This bottom example shows the bolt when it's completely fished through the vehicle. You may find it easier to keep the bolt fisher attached until you get the tie down receiver in place so that the bolt doesn't fall into the vehicle frame.

WARNING: PULLING TOO HARD ON THE BOLT FISHER CAN RESULT IN LOST FASTENERS, OR BROKEN BOLT FISHER.