



## BATTERY MONITOR BW-03 | OWNER'S MANUAL

**READ OWNER'S MANUAL CAREFULLY BEFORE INSTALLING BW-03.**

### Description

The BW-03 is a smart battery monitor that can measure and display the voltage of one or two battery bank(s). It can also generate an alarm for overvoltage, undervoltage and voltage differences.

### Features

- Shallow mounting depth
- Multiple battery monitoring
- Open Drain alarm output
- Programmable alarm thresholds
- Very low power consumption
- Auto 12V / 24V detection
- Power Saving Mode
- Easy to install
- Splash resistant on top

### Layout

Layouts of the top and back of the unit are shown in Fig 1A & 1B, respectively.

### Installation

#### Warnings

- The unit should be installed only by skilled installers / electricians who are aware of regulations for working with batteries.
- Live parts must never come into contact with the housing of the BW-03.
- Use of poor quality material and/or excessively low diameter cables for making the connections can damage the BW-03.
- A short circuit between the Positive and Negative terminals of the battery may cause severe damage to your system.
- Always use fuses (of the correct value) as shown in the connection diagrams (pages 3 & 4).

Various connection configurations are shown in Figs 2 to 7. Please strictly follow the order of connections given below:

#### Monitoring 1 Battery Bank

**(Figs. 3 and 4):**

1. Connect the Negative of the battery bank to the Minus Input Terminal marked (MIN).
2. (Optional) Connect the external alarm relay / LED from the battery Positive to the Alarm output Terminal (OUT) - See Fig 2.
3. Connect the Positive terminal of the battery to the Positive Input Terminal marked (BAT1).

#### Monitoring 2 Battery Banks

**(Figs. 5, 6 and 7):**

1. Connect the Negative of the 2 battery banks to the Minus Input Terminal marked (MIN).
2. (Optional) Connect the external alarm relay / LED from the battery Positive to the Alarm output Terminal (OUT) - See Fig 2.
3. Connect the Positive terminal the first battery bank (any one of the two battery banks) to the Positive Input Terminal marked (BAT 2) .

**NOTE: It is important the this first connection is made on Terminal (BAT 2) and NOT on Terminal (BAT1).**

4. Connect the Positive Terminal of the second battery bank to the Positive Input Terminal marked (BAT1).

### Operation

Immediately after connection, the voltage of BAT 1 is displayed to an accuracy of one tenth of a Volt. If use is also made of the BAT 2 terminal, then the BAT 1 point (1B, Fig 1A) will flash slowly (1x per 2.5 second). This is to indicate which battery voltage is actually being displayed. When the Programming Button is pushed briefly (for less than 2 seconds), the voltage of BAT 2 appears on the display. The associated indication point, BAT 2 (1D, Fig 1A), now flashes slowly.

### Alarm

BW-03 can generate an alarm for three different situations. These are alarms for undervoltage, overvoltage and voltage difference (programmable values are given in Table 1). As soon as an alarm starts, the display will continuously switch between showing the alarm that has been activated ("lo", "hi" or "dif") and the voltage value of the selected voltage input. The buzzer and Alarm Out Terminal (OUT, Fig 1B) will also be activated.

An alarm lasts for one minute, or until the Programming Button (2, Fig 1A) has been pressed for two seconds. After this, the alarm state continues in silence. This means that the buzzer and Alarm Out Terminal (OUT, Fig 1B) have now been deactivated and the display – just like normal – continuously indicates the reading from the selected battery. One of the Battery 1 (1B, Fig. 1A) or Battery 2 (1D, Fig. 1A) points will now start to flash quickly ( $\pm 2x$  per second) to indicate there is an alarm. In the case of a difference alarm, both points will flash quickly. The alarm is fully reset as soon as the voltage reaches a normal value once again.

### Power Saving Mode

If a voltage is connected to BAT 1 that results in the activation of an undervoltage alarm, the display will be switched OFF 10 minutes after the starting of the alarm. The application will continue to work in the background and if another voltage level is exceeded, the alarm will activate. In this case, the display is also (temporarily) switched ON. The display is also switched ON if the Programming Button is pushed or if the voltage of the BAT 1 input rises.

As long as the voltage has not risen above the charging voltage for three days (12.8V for a 12V system and 25.6V for a 24V system), there has been no alarm and the user has also not pressed the Programming Button, then the application will reduce power consumption further by suspending all activities. Briefly pressing the Programming Button switches OFF the Power Saving Mode and the BW-03 operates normally again.

### Programming

Programming functions are carried out with the help of the Programming / Select Button (2, Fig 1A). This button performs the following functions:

1. Changing the displayed voltage.
2. Resetting the alarms.
3. Discontinuing Power Saving Mode.
4. Configuring alarm values (see Table 1).

The first three functions have been covered earlier in this manual so that only the programming of the software still remains.

As soon as the Programming Button is pressed for four seconds, the display will turn OFF for a moment to indicate that the Programming Menu has been activated. Next, "lo" appears in the display, followed by the value 10.8V (21.6V), the default value – see Table 1. This means that the undervoltage alarm can be adjusted and that it is currently set to 10.8V (21.6V). This value can be changed by pressing the Programming Button. If this is done, the value will be increased by 0.1V for each press. This continues until the value of 12V is reached. If the button is pressed again, the lowest value in the table – 10.5V – is displayed. As soon as the desired value is displayed, there is a 4 second delay until "YES" is displayed. This indicates that the value chosen has been accepted.

Next, the display remains blank for a moment once again followed by the text "hi". Immediately after this, a voltage value (default value of 14.8V (29.6V) - Table 1) is displayed once again. This is the overvoltage setting alarm value. This can also be adjusted by pressing the Programming Button.

### Differential Voltage Alarm

For a 24V system with a centre terminal (see Fig 7), there is also the additional option of activating and adjusting a differential voltage alarm. After the overvoltage, the display will turn OFF for a moment again followed by the display of "dif". Here again, a voltage value can be selected (default is OFF "----" see Table 1). The difference from the previous two values is that now, the value displayed is in millivolts and not Volts. Another difference is that here also, the option "----" can be chosen. If this is done, the voltage differential alarm is switched OFF.

# BATTERY MONITOR BW-03 | OWNER'S MANUAL

After the last programmable value has been set, the display switches OFF for a moment once again and BW-03 functions normally again. This set value is memorised if BW-03 is (temporarily) de-energised.

**Table 1: Programmable Alarm Settings**

	Undervoltage		Overvoltage		mV
	12V	24V	12V	24V	
1	10.5V	21.0V	14.6V	29.2V	* ---
2	10.6V	21.2V	14.7V	29.4V	400 mV
3	10.7V	21.4V	14.8V*	29.6V*	450 mV
4	10.8V*	21.6V*	14.9V	29.8V	500 mV
5	10.9V	21.8V	15.0V	23.0V	550 mV
6	11.0V	22.0V	15.1V	23.2V	600 mV
7	11.1V	22.2V	15.2V	23.4V	650 mV
8	11.2V	22.4V	15.3V	23.6V	700 mV
9	11.3V	22.6V	15.4V	23.8V	750 mV
10	11.4V	22.8V			800 mV
11	11.5V	23.0V			
12	11.6V	23.2V			
13	11.7V	23.4V			
14	11.8V	23.6V			
15	11.9V	23.8V			
16	12.0V	24.0V			

\* Default settings

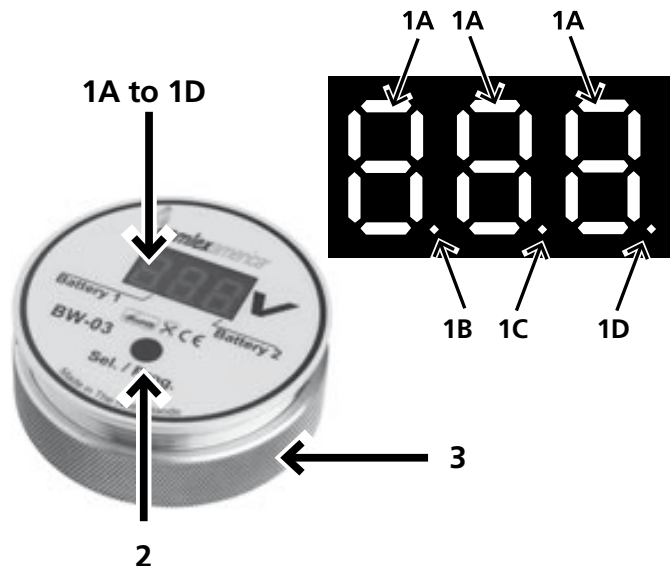

## LEGEND

- 1A 3 Digit, 7 Segment. LED Display (Steps of 0.1V)
- 1B LED dot showing that voltage of Battery 1 is being displayed
- 1C LED dot showing decimal point for voltage reading
- 1D LED dot showing that voltage of Battery 2 is being displayed
- 2 Select / Programming Button
- 3 Knurled Ring Nut

**Fig 1A: Layout - Top of Unit**

SPECIFICATIONS		
Parameter	12V	24V
Supply Voltage Range	6VDC to 31VDC	
Nominal Battery Voltage	12V / 24V, Auto Sensing	
Display	3 Digit, 7 Segment LED Display; Accuracy: 0.1V	
Current Consumption	Display ON	20mA
	Display OFF	8mA
	Power Save Mode	< 0.1mA
Programmable Voltage Settings for Alarm	Under Voltage 12V (24V): 10.5V to 12.0V (21.0V to 24.0V) Default: 10.8V (21.6V)	
	Over Voltage 12V (24V): 10.5V to 12.0V (29.2V to 23.8V) Default: 14.8V (29.6V)	
Alarm Output	Open Drain, 500 mA maximum Switches to (-) of battery when alarm is activated	
Input Connections	Terminal Block: Tubular Hole with set screw	
Connecting Wire Size / Fuse Rating	AWG # 18 to 20 or 0.75mm <sup>2</sup> / 32V. 0.5A	
Dimensions	Height / Diameter: 60mm Depth: 20 mm Diameter of Mounting Hole: 55mm Mounting Depth: 18mm	
Weight	200g	
Materials	Housing: Anodized Aluminum Top Label: Polycarbonate	
Certifications	CE Marked; RoHS Compliant	

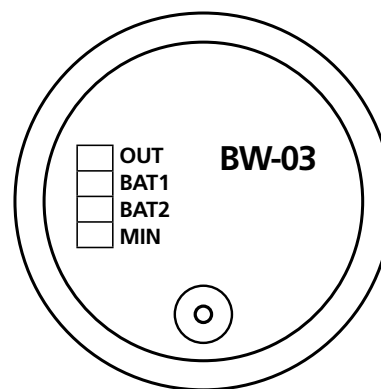

## LEGEND

**NOTE: If 2 battery banks are connected, connect to BAT2 first and then to BAT1.**

- OUT - Drain Pin of Open Drain; Max. 500 mA
- BAT1 - Connection for Positive of Battery 1
- BAT2 - Connection for Positive of Battery 2
- MIN - Connection for Common Negative

**Fig 1B: Layout - Back of Unit**

## Connection Diagrams

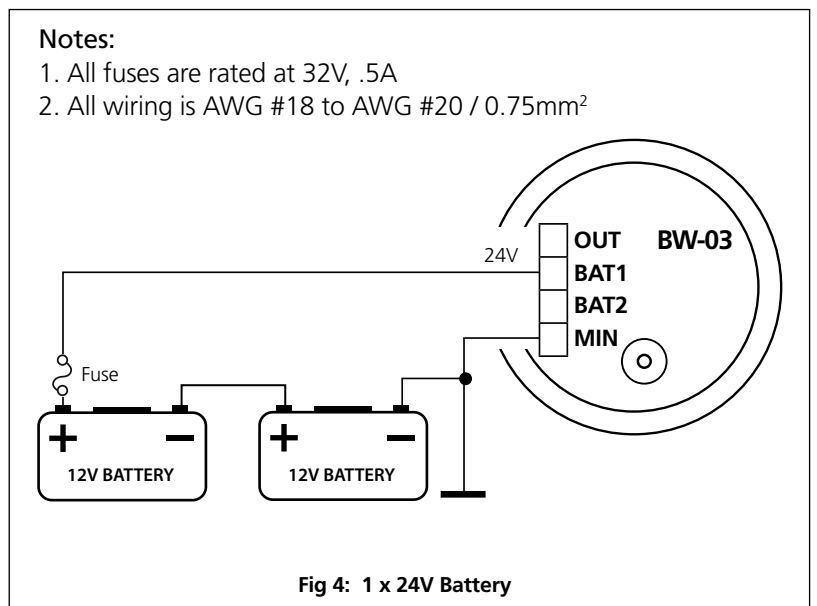
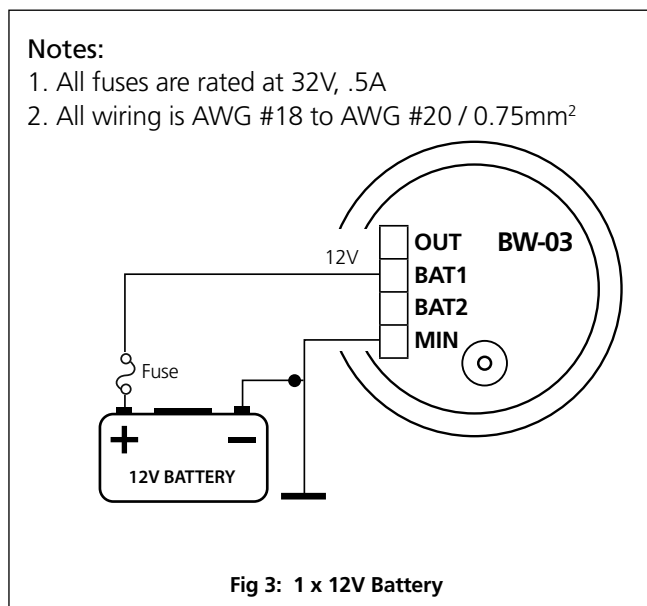
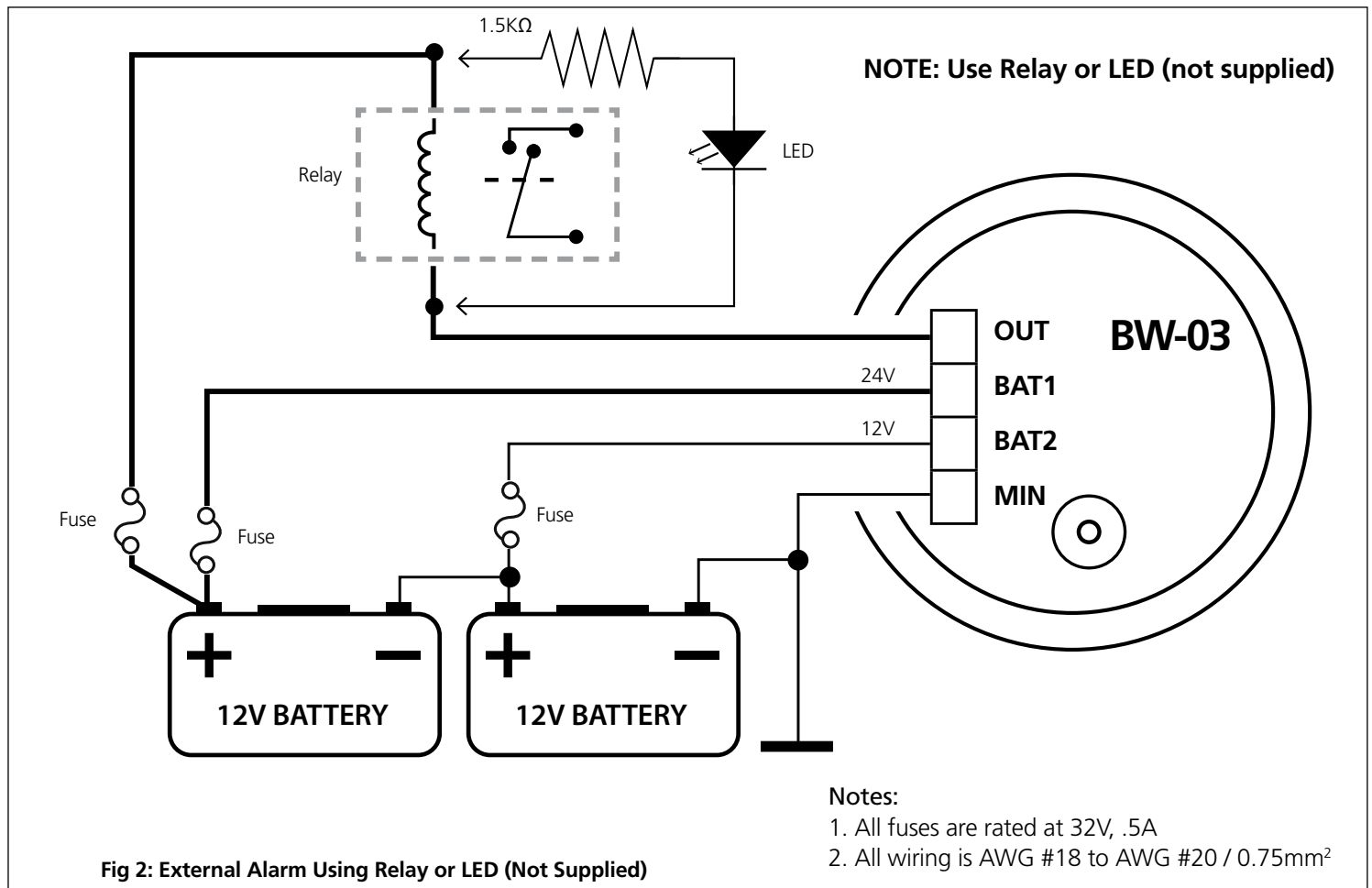

## Connection Diagrams (continued)

**Notes:**

1. All fuses are rated at 32V, .5A
2. All wiring is AWG #18 to AWG #20 / 0.75mm<sup>2</sup>

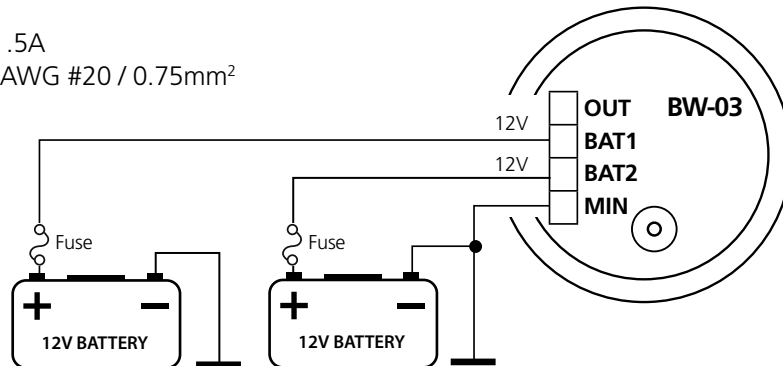

**Fig 5: 2 x 12V Batteries**

**Notes:**

1. All fuses are rated at 32V, .5A
2. All wiring is AWG #18 to AWG #20 / 0.75mm<sup>2</sup>

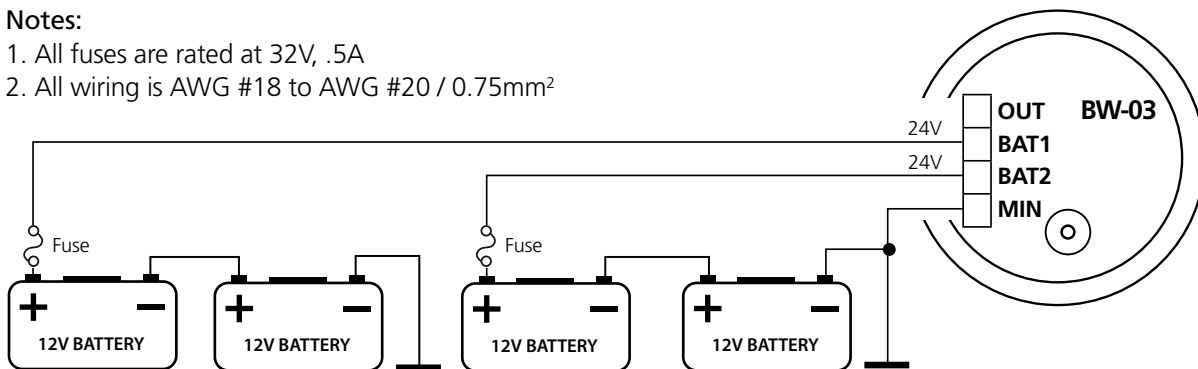

**Fig 6: 2 x 24V Batteries**

**Notes:**

1. All fuses are rated at 32V, .5A
2. All wiring is AWG #18 to AWG #20 / 0.75mm<sup>2</sup>

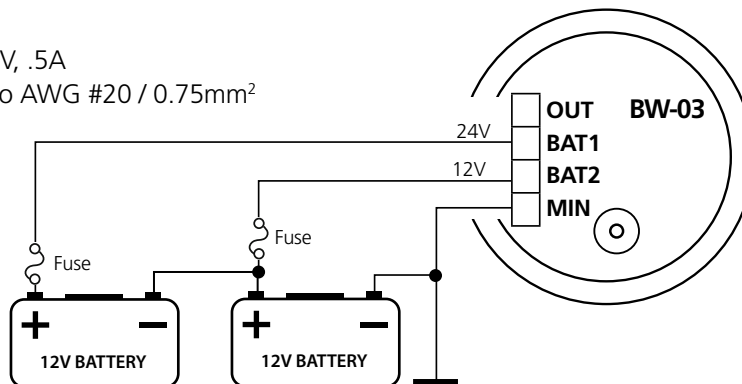

**Fig 7: 1 x 12V Battery & 1 x 24V Battery**