

Maintenance sheet

ATH3
68A166-2

A. Troubleshooting

If the error code is indicated on the green LED (Refer to Section C) on the PCB (Part #701) of the water heater (and/or the remote controller), refer to Section B.

<< It takes long time to get hot water at the fixtures >>

- The time it takes to deliver hot water from the water heater to your fixtures depends on the length of piping between the two. The longer the distance or the bigger the pipes, the longer it will take to get hot water.
- If you would like to receive hot water to your fixtures quicker, you may want to consider a hot water recirculation system.

<< The water is not hot enough or turns cold and stays cold >>

- Compare the flow and temperature. Refer to the “Output temperature chart” of the Installation manual.
- Check cross plumbing between cold water lines and hot water lines.
- Check if the gas supply valve is fully open, the gas line is sized properly and the gas supplies enough pressure. Refer to the “Gas supply and gas pipe sizing” of the Installation manual.
- Check the set temperature, and change the set temperature with the remote controller or the DIPswitch setting. Refer to Section D.
- Refer to the “Water circuit” in this section.

<<The water is too hot>>

- Check the set temperature, lower setting temperature.

<<The hot water is not available when a fixture is opened>>

- Refer to the “Power supply circuit” and “Water circuit” in this section.

<<Fluctuation in hot water temperature>>

- Check if the filter on the cold water inlet is cleaned. (Part #406)
- Check if the gas line is sized properly and the supply gas pressure is sufficient.
- Check for cross connection between cold water lines and hot water lines.
- Refer to the “Water circuit” in this section.

<<Unit does not ignite when water goes through the water heater>>

- Refer to the “Power supply circuit” and “Water circuit” in this section.
- If you use the remote controller, turn the power button on and then check if the STAND BY LED will light up.
- Check if the filter on the cold water inlet is cleaned (Part #406).
- Refer to the “Water circuit” in this section.

B. Error codes

*The 341, 751 and 941 error codes are applied to the 540 (T-H3) Indoor models only.

031: Incorrect DIPswitch setting

- Check the DIPswitch settings on the PCB. Refer to Section D.

101: Warning for the “991” error code

- Check the gas type of the house (and/or the building).
- Check if there is any blockage in the intake air and/or exhaust. Refer to the “Venting Instructions” of the Installation manual.
- If the water heater is installed as a direct-vent system, check whether there is enough distance between the intake air terminal and the exhaust terminal. Refer to the “Vent termination clearances” of the Installation manual.
- Check the total vent length. Refer to the “Venting instructions” of the Installation manual.
- Check the altitude/elevation of area of where the water heater is installed. Refer to the “High-altitude function” of Section D. And change the DIPswitch settings.
- Check if there is grease and/or dirt in the burner (Part #101) and the fan motor (Part #103), especially if the water heater has been installed in a contaminated area.
- Check if there is dust and lint in the heat exchanger.
- Check the manifold pressure of the water heater. Refer to the Installation manual of the water heater.

111: Ignition failure

- Check the gas supply and inlet gas pressure.
- Check if the Hi-limit switch (Part #412) is properly functioning.
- Check for connection/breakage of wires (Part #413, 708, 709, 710, 712), and/or soot on the flame rod (Part #108). And then if the O.H.C.F (Part #413) has a breakage, **Consult the manufacturer.**
- Check if there is a buzzing spark ignition sound coming from the burner (Part #101) when water heater prepares for combustion.
- Listen for the double “clunk” sound coming from the gas valve assembly (Part #102) when water heater goes into combustion.
- (Only if sparking and/or kick sound) Check the voltage on each wire to gas valve assembly (Part #102) and/or the igniter assembly (Part #711). Refer to “Appendix A” in Section C.
 - *No sparking sound >>>> Refer to #1 at “Appendix A” in Section C.
 - *No kick sound >>>> Refer to #2 at “Appendix A” in Section C.
- Check if there is leaking from the heat exchanger (Part #401).
- Check if there is dust and lint in nozzles of the manifold (Part #102).
- Check the current on the flame rod (Part #108). Refer to #3 at “Appendix A” in Section C.

121: Loss of flame

- Check the gas supply and inlet gas pressure.
- Check if the Hi-limit switch (Part #412) is properly functioning.
- Check for connection/breakage of wires (Part #413, 708, 709, 712), burn marks on the computer board (Part #701), and/or soot on the flame rod (Part #108). And then if the O.H.C.F (Part #413) has a breakage, **Consult the manufacturer.**
- Check if there is leaking from the heat exchanger (Part #401).
- Check if there is dust and lint in nozzles of the manifold (Part #102).
- Check the current on the flame rod (Part #108). Refer to #3 at “Appendix A” in Section C.

311,321,331,341*: Disconnected/short-circuited thermistor

- Check for connection/breakage of wires and/or debris on the thermistor (Part #407, 408, 411, 715, 718).
- Check the thermistor resistance. Refer to “Appendix D” in Section C.

391: Air-fuel ratio rod failure

- Check for connection/breakage of wires (Part #709) and/or soot on the flame rod (Part #108).

441: Flow sensor failure (Only Easy-Link system)

- Check for connection/breakage of wires and/or debris on the flow sensor impeller (Part #402).

<<The fan motor is still spinning after operation has stopped>>

- This is normal. After operation has stopped, the fan motor keeps running from 15 to 70 seconds in order to re-ignite quickly, as well as purge all the exhaust gas out of the flue.

<<Abnormal sound from water heater>>

- An abnormal sound from the water heaters is caused by not enough air supply or wrong installations. The water heater needs more combustion air. Refer to the “101” error code in the section B.

<<Power supply circuit>>

- If the remote controller is installed, press the “ON/OFF” button of the remote controller, and make sure that the STAND BY LED next to the “ON/OFF” button of the remote controller is lit. Restart the water heater.
- Check if the green LED on the PCB (Part #701) of the water heater is lit. If so, the power supply circuit of the water heater is under normal condition. Next, refer to the “Water circuit” in this section.
- Check the fuse on the surge box (Part #703), and if it has a brown spot, need to replace it.
- Check the power supply, and make sure that the water heater has 120 VAC.
- If the green LED on the PCB (Part #701) isn’t lit, some electrical parts can be broken. **Consult the manufacturer.**

<<Water circuit>>

- If you use the remote controller, turn the power button on and then check if the STAND BY LED will light up.
- Open all hot water faucets, and make sure that there is enough water flow. This water heater needs at least 0.5 GPM water flow (at the default set temperature) to operate.
- Check for reverse connection and cross connection.
- Check if the filter on the cold water inlet is cleaned (Part #406).
- Check if there is no debris or obstruction on the fixtures.
- Check if water ways in the water heater are frozen. If so, unfreeze them. And refer to the Installation manual to protect your water heater from freezing.
- Check if the inlet water pressure is higher than 40 psi. And if it’s lower than 40 psi, need to increase the pressure.
- Check for connections and breakage of wires (Part #402).
- Check if the motor drive of the flow adjustment valve (Part #402) is locked due to scale buildup, and/or water leakage. If so, **Consult the manufacturer.**

510,551: Abnormal main gas solenoid valve and gas solenoid valve

- Check for connection/breakage of wires (Part #708) and/or burn marks on the computer board (Part #701).
- Reset power supply of the water heater.
- Check the voltage of each valve on the gas valve assembly (Part #102). Refer to “Appendix C” in Section C.

611: Fan motor fault

- Check for connection/breakage of wires, dust buildup in the fan motor (Part #103) and/or burn marks on the computer board (Part #701).
- Check for frozen/corrosion of connectors of the fan motor (Part #103).
- Check the voltage between blue wire and each wire of the fan motor (Part #103). Refer to “Appendix B” in Section C.

651: Flow adjustment valve fault (Only Easy-Link System)

- Inspect the flow adjustment valve (Part #402), for connection/breakage of wires, locked motor drive due to scale buildup, and/or water leakage.
- Check the voltage between black wire and red wire. Refer to “Appendix F” in Section C.

661: Bypass valve fault

- Inspect the bypass valve (Part #403), for connection/breakage of wires, locked motor drive due to scale buildup, and/or water leakage.
- Check the voltage between brown wire and red wire. Refer to “Appendix F” in Section C.

701: Computer board fault

- Check for connection/breakage of wires (Part #714), and check the resistance between white wire and red wire. Refer to “Appendix A” in Section C.

711: Gas solenoid valve drive circuit failure

- Refer to the “111” and “121” error codes in this section.

721: False flame detection

- Clean the flame rod (Part #108).
- Check if there is leaking from the heat exchanger (Part #401).

741: Miscommunication between water heater and remote controller

- Check the model type of the remote controller. Model No. 9009069005 (TM-RE42) or 9008172005 (TM-RE40) is the correct one.
- Inspect the connections between the water heater and remote controller. Refer to the “Remote controller connections” of the Installation manual.
- Check the power supply of the water heater.
- If this error code appears only on the green LED in the PCB (Part #701), check the voltage on the remote controller terminal on the PCB. Refer to “Appendix E” in Section C.
- If this error code appears only on the remote controller, replace the PCB (Part #701).
- If this error code appears on both the PCB (Part #701) and the remote controller, replace the remote controller.

751*: Miscommunication between water heater and temperature controller

- Check the power supply of the water heater.
- If this error code appears only on the green LED in the PCB (Part #701), check the voltage on the remote controller terminal on the PCB. Refer to “Appendix E” in Section C.
- If this error code appears only on the temperature controller, replace the PCB (Part #701).
- If this error code appears on both the PCB (Part #701) and the temperature controller, replace the temperature controller.

761: Miscommunication between Parent unit and Child units for Easy-Link System

- Check if the connections between the parent unit and the child units are correct. Refer to the “Easy-Link system” section in the Installation manual.

941*: Abnormal exhaust temperature (Only 540 (T-H3) Indoor model)

- Check for connection/breakage of wires, dust buildup in the fan motor (Part #103) and/or burn marks on the computer board (Part #701).
- Check the exhaust thermistor resistance. Refer to “Appendix D” in Section C.

991: Imperfect combustion

- Refer to the “101” error code in this section.

C. Wiring diagram and check point of the water heater

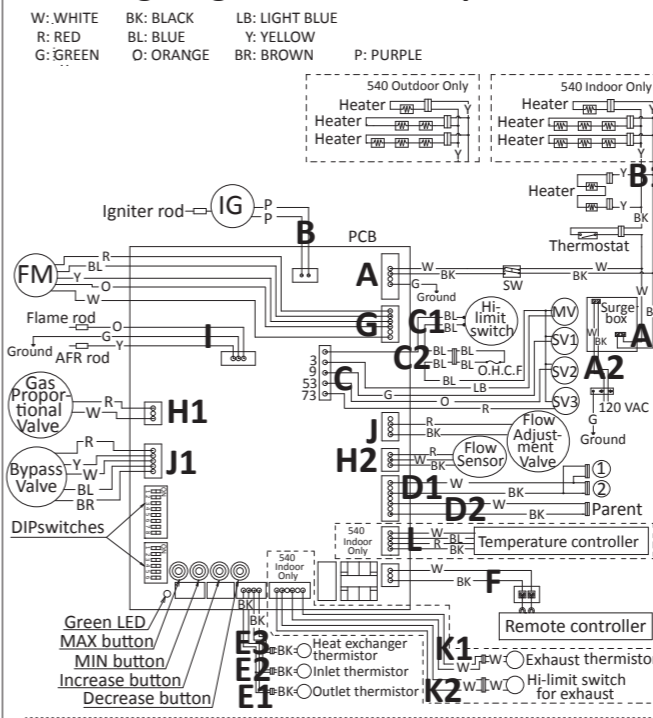

Appendix A (For error code 111)

Check the following points during ignition stage.

- Refer to check point “B” on the wiring diagram above. Check the voltage between purple wires. (Normal: 108 to 132 VAC)
This check point is normal?
Yes >> Replace the igniter assembly (Part #711).
No >> Go to Next.
- Refer to check points “C” and “H1” on the wiring diagram above. Check the voltages below:
C: Between blue wire and light blue wire (#3). (Normal: 93 to 120 VDC)
C: Between blue wire and orange wire (#53). (Normal: 93 to 120 VDC)
H1: Check the voltage between white wire and red wire. (Normal: 1 to 15 VDC)
These check points are normal?
Yes >> Replace the gas valve assembly (Part #102).
No >> Replace the PCB (Part #701).
- Check the current through the yellow flame rod wire (Part #709). (Normal: more than 5 μA)
This check point is normal during operation?
Yes >> Replace the PCB (Part #701).
No >> Replace the flame rod (Part #108).

Appendix F (For error code 651 and 661)

- Error code 651 : Refer to check point “J” on the wiring diagram above. Check the voltage between black wire and red wire. (Normal: 7 to 16 VDC)
Error code 661 : Refer to check point “J1” on the wiring diagram above. Check the voltage between brown wire and red wire. (Normal: 3 to 11 VDC)
This check point is normal?
Yes >> Error code 651: Replace the Flow adjustment valve (Part #402). / Error code 661: Replace the Bypass valve (Part #403).
No >> Replace the PCB (Part #701).

D. DIPswitch settings on the computer board of the water heater

Locate the bank of DIPswitches at the bottom left of the computer board of the unit.

Change the DIPswitch settings when the power supply is turned off.

The dark square is the direction the DIPswitch should be set to. DEFAULT is the factory setting.

<Upper bank of DIPswitches>

Vent settings (Indoor models only)				Gas type*				Model type*			
3" venting	5 to 20 ft (DEFAULT)	21 to 40 ft	41 to 70 ft	Propane	ON <input type="checkbox"/> 1 2 3 4 / OFF <input type="checkbox"/>	Indoor model	ON <input type="checkbox"/> 1 2 3 4 5 / OFF <input type="checkbox"/>	Natural Gas	ON <input type="checkbox"/> 1 2 3 4 / OFF <input type="checkbox"/>	Outdoor model	ON <input type="checkbox"/> 1 2 3 4 5 / OFF <input type="checkbox"/>
4" venting	5 to 50 ft (DEFAULT)	51 to 100 ft	N/A								

Set DIPswitches shown in the table above depending on the vent length. *Factory setting

Upper bank	Lower bank	Temperature set		High-altitude function	
		Indoor model	Outdoor model		
		120 °F (49 °C)	ON <input type="checkbox"/> 1 2 3 4 5 6 / OFF <input type="checkbox"/>	0 to 2,000 ft. (DEFAULT)	ON <input type="checkbox"/> 1 2 3 4 5 6 / OFF <input type="checkbox"/>
		140 °F (60 °C)	ON <input type="checkbox"/> 1 2 3 4 5 6 / OFF <input type="checkbox"/>	2,000 to 3,000 ft.	ON <input type="checkbox"/> 1 2 3 4 5 6 / OFF <input type="checkbox"/>
			ON <input type="checkbox"/> 1 2 3 4 5 6 / OFF <input type="checkbox"/>	3,000 to 5,000 ft.	ON <input type="checkbox"/> 1 2 3 4 5 6 / OFF <input type="checkbox"/>
		Easy-Link System Parent Unit ON <input type="checkbox"/> 1 2 3 4 5 6 / OFF <input type="checkbox"/> Child Unit (DEFAULT) ON <input type="checkbox"/> 1 2 3 4 5 6 / OFF <input type="checkbox"/>		5,000 to 7,500 ft. ON <input type="checkbox"/> 1 2 3 4 5 6 / OFF <input type="checkbox"/> 7,500 to 10,100 ft. ON <input type="checkbox"/> 1 2 3 4 5 6 / OFF <input type="checkbox"/>	

Single unit is the same as the child unit. FM speed is increased automatically.

Appendix B (For error code 611)

- Refer to check point “G” in the diagram to the left and the following.
- Check the voltage between red wire and blue wire (Normal: 132 to 192 VDC).
 - Check the voltage between yellow wire and blue wire (Normal: 13 to 17 VDC).
 - Check the voltage between orange wire and blue wire (Normal: 2.0 to 6.5 VDC).
- All check points are normal?**
Yes >> Replace the fan motor (Part #103).
No >> Replace the PCB (Part #701).

Appendix C (For error code 510 and 551)

- Refer to check point “C” in the diagram to the left and the following. Check the voltage on each valve on the gas valve assembly.
- Between blue wire and light blue wire (#3) (Normal: 93 to 120 VDC).
 - Between blue wire and green wire (#9) (Normal: 93 to 120 VDC).
 - Between blue wire and orange wire (#53) (Normal: 93 to 120 VDC).
 - Between blue wire and red wire (#73) (Normal: 93 to 120 VDC).
- All check points are normal?**
Yes >> Replace the gas valve assembly (Part #102).
No >> Replace the PCB (Part #701).

Appendix D (For error code 311, 321, 331, 341, and 941)

- Outlet thermistor (Find the marking of No.113 on the connector) Check point “E1”
 - Inlet thermistor (Find the marking of No.42 on the connector) Check point “E2”
 - Heat exchanger thermistor (Find the marking of No.12 on the connector) Check point “E3”
- Check the resistance between black wire and black wire.

Temperature	°F	50	59	68	77	86	95
	°C	10	15	20	25	30	35
Resistance	kΩ	15.4	12.6	10.3	8.5	7.0	5.9

- Exhaust thermistor Check point “K1”
- Check the resistance between white wire and white wire.

Temperature	°F	50	59	68	77	86	95
	°C	10	15	20	25	30	35
Resistance	kΩ	19.5	15.9	13.0	10.7	8.9	7.4

- All check points are normal?**
Yes >> Replace the PCB (Part #701).
No >> Replace the thermistor (Part #407, 408, 411, 718).

Appendix E (For error code 741 and 751)

- Error code 741: Refer to check point “F” on the wiring diagram above.
Error code 751 : Refer to check point “L” on the wiring diagram above. Check the voltage on the remote controller and/or temperature controller on the PCB. • Between black wire and white wire. (Normal: 11 to 25 VDC)
This check point is normal?
Yes >> Replace the remote controller and/or temperature controller.
No >> Replace the PCB (Part #701).

E. Components diagram / Parts list

Case assembly

Indoor model

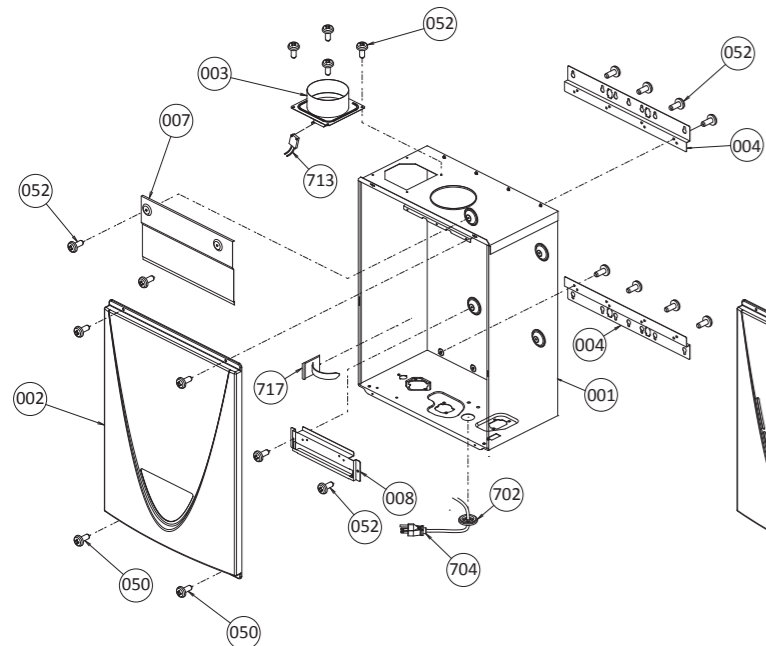

Outdoor model

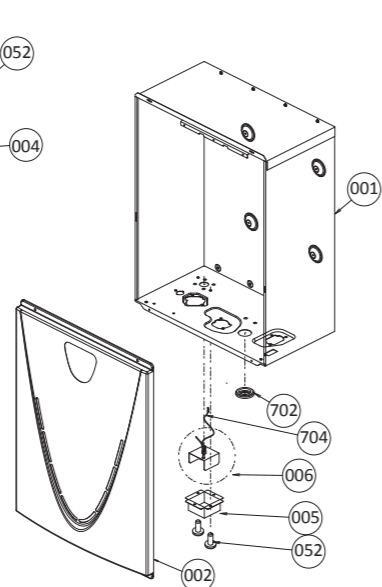

Temperature remote controller

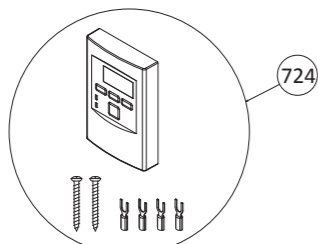

Burner assembly

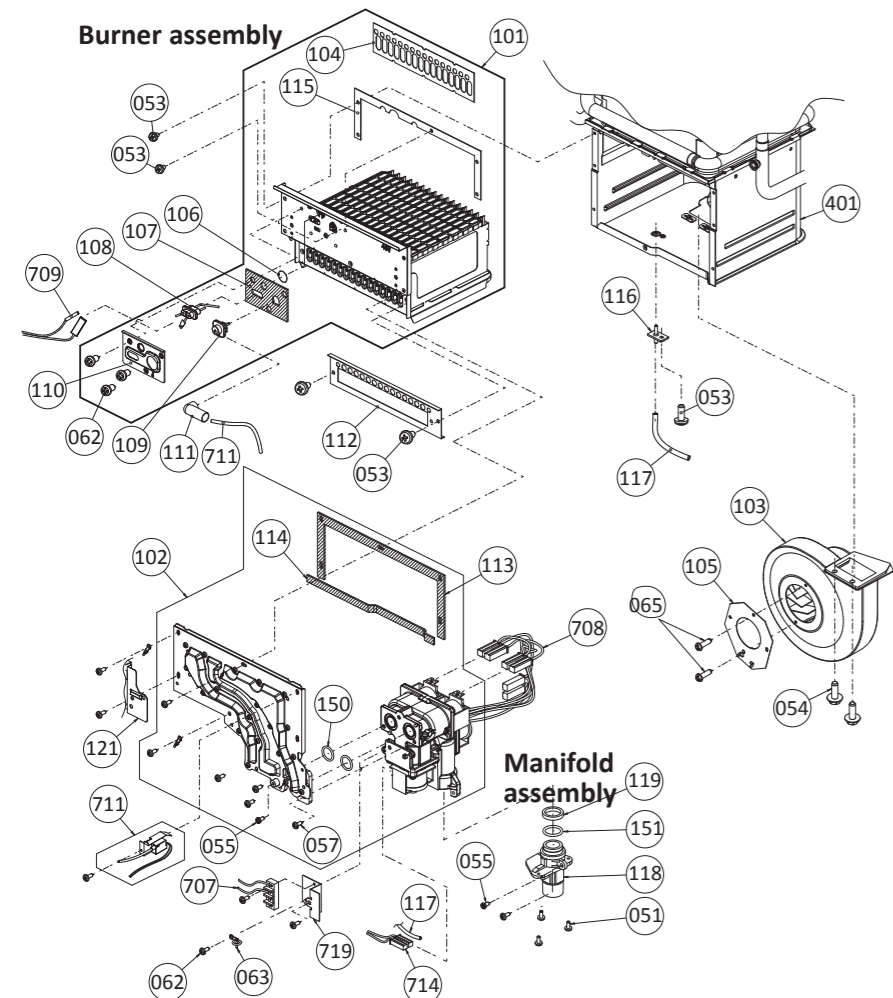

Water way assembly

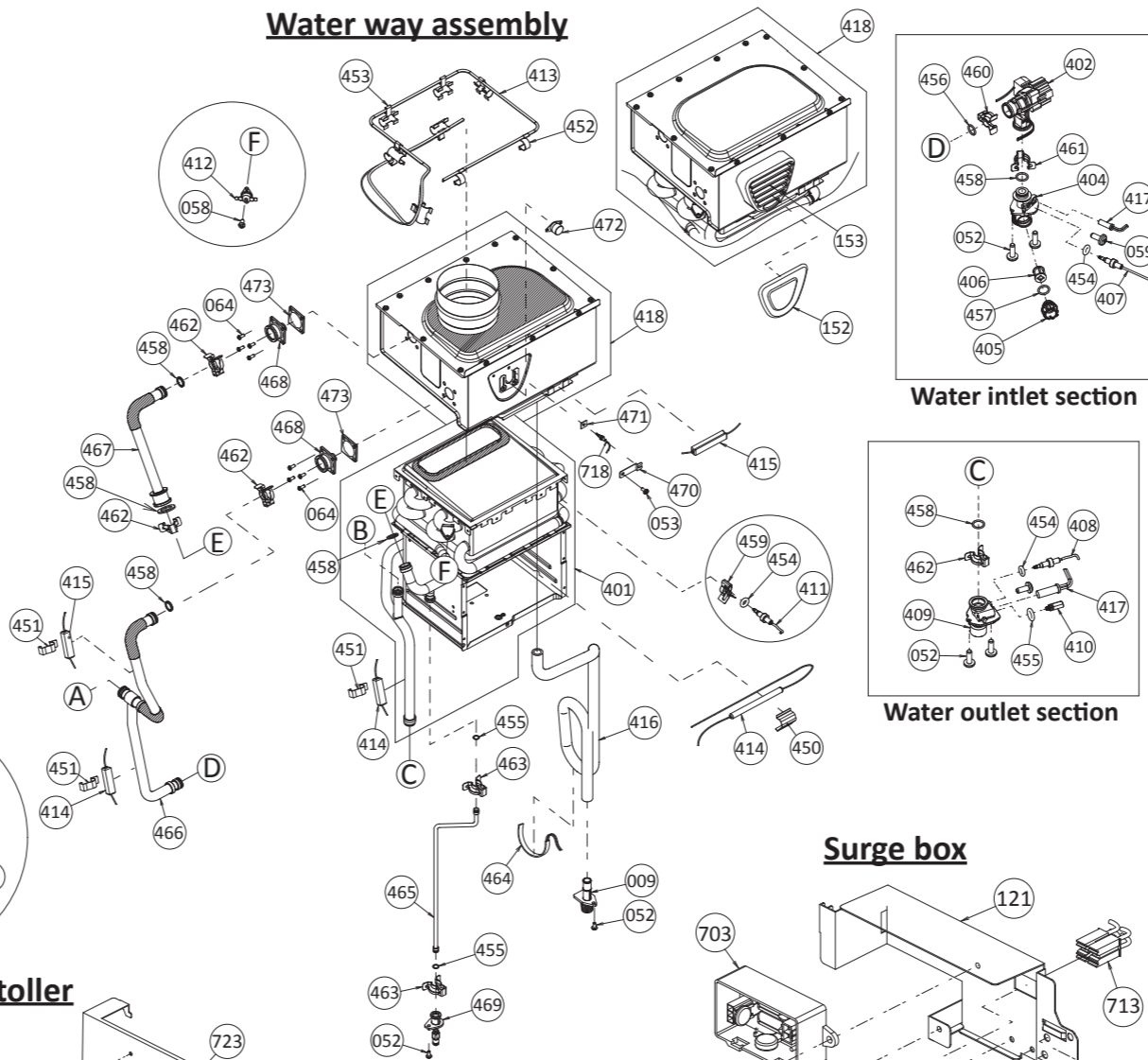

Computer board assembly

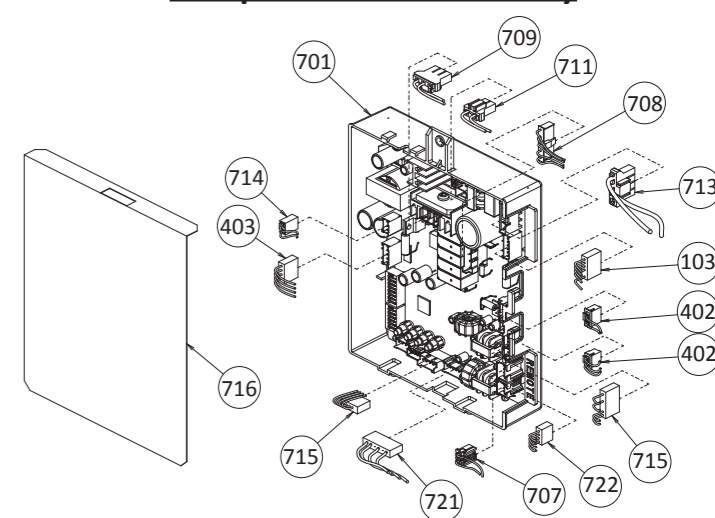

Bypass section

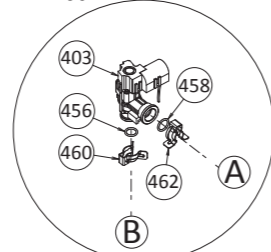

Temperature controller Indoor model

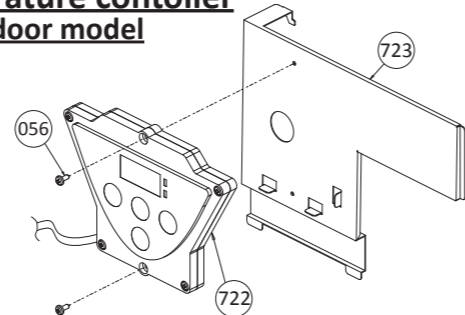

Item #	Part #		Description
	540 model	T-H3 model	
001	N/A	EK159	Case assembly for Indoor models
	N/A	EK164	Case assembly for Outdoor models
002	319143-507	EK158	Front cover for Indoor models
	319143-508	EK174	Front cover for Outdoor models
003	319143-509	EK170	Intake air port assembly
004	N/A	EK162	Bracket
005	319143-510	EK190	Junction box
006	319143-511	EK171	Power supply cord assembly
007	319143-512	EK161	Back guard panel
008	319143-513	EK160	Chamber fixing plate
009	319143-018	EKH23	Condensate drain port
050	319143-025	EW000	Screw M4x12 (W/Washer)
051	319143-325	EW001	Screw M4x10 (W/Washer)
052	319143-026	EW002	Screw M4x10 (Coated)
053	319143-060	EW003	Screw M4x10
054	319143-326	EW004	Hex head screw M4x12 (W/Washer)
055	319143-063	EW005	Hex head screw M4x8
056	N/A	EW018	Pan screw M4x20
057	319143-201	EKK31	Tap tight screw M4x12 FEZN
058	319143-087	EW00A	Screw M3x6
059	319143-328	EW009	Screw M4x6
060	319143-438	EKK37	Screw M4x12
061	N/A	EK191	Screw M3x6
062	319143-059	EW00D	Pan screw M4x8
063	319143-048	EM167	Wire clamp 60
064	N/A	EK230	Screw M4x10
065	319143-330	EW00B	Screw M3x6 SUS3

Item #	Part #		Description
	540 model	T-H3 model	
101	319143-514	EK192	Burner assembly
102	319143-515	EK181	Manifold with gas valve assembly LP
	319143-516	EK182	Manifold with gas valve assembly NA
103	319143-443	EK109	Fan motor for Indoor models
	319143-043	EKK25	Fan motor for Outdoor models
104	319143-031	EKK2X	Burner gasket
105	319143-282	EM381	Fan damper for Indoor models
106	319143-033	EKK2V	Burner window
107	319143-034	EKK2W	Rubber gasket
108	319143-517	EK193	Flame rod
109	319143-037	EKK0F	Igniter rod
110	319143-036	EKK32	Rod holder
111	319143-038	EKN61	Rod cap
112	319143-518	EK183	Burner damper LP
	319143-519	EK169	Burner damper NA
113	319143-044	EKK2Y	Manifold gasket A
114	319143-045	EKK2K	Manifold gasket B
115	319143-032	EKK0G	Burner holder gasket
116	319143-042	EKK2D	Pressure port
117	319143-520	EX019	Combustion chamber tube
118	319143-455	EK117	Gas inlet
119	319143-342	EX00D	Gas inlet ring
121	319143-522	EK163	Surge box plate
150	319143-350	EZP18	O-ring P18 NBR (Black)
151	319143-057	EK042	O-ring P20 NBR (Black)
152	319143-523	EK157	Silicon ring for Outdoor models
153	319143-524	EK177	Exhaust port for Outdoor models
401	319143-548	EK250	Primary heat exchanger assembly
402	319143-463	EK129	Flow adjustment valve / Flow sensor
403	319143-464	EKD58	Bypass valve
404	319143-193	EKK1U	Water inlet

Item #	Part #		Description
	540 model	T-H3 model	
405	319143-197	EKK2B	Inlet drain plug
406	319143-198	EKK2C	Inlet water filter
407	319143-465	EK137	Inlet thermistor
408	319143-190	EKK1A	Outlet thermistor
409	319143-530	EK208	Water outlet
410	319143-199	EKK2E	Outlet drain plug
411	319143-096	EKK2T	Heat exchanger thermistor
412	319143-095	EKN34	Hi-Limit switch
413	319143-149	EK333	Overheat-cut-off fuse
414	319143-531	EK209	Pipe heater
415	319143-532	EK210	Inlet heater for Indoor models
	319143-533	EK211	Inlet heater for Outdoor models
416	319143-534	EK231	Drain tube
417	319143-468	EK105	Inlet heater
418	319143-549	EK251	Secondary heat exchanger for Indoor models
	319143-550	EK256	Secondary heat exchanger for Outdoor models
450	319143-088	EKK27	Pipe heater fixing plate
451	319143-125	EK031	Heater fixing plate 16
452	319143-066	EKK26	Fuse fixing plate 18
453	319143-146	EK029	Fuse fixing plate 14
454	319143-082	EZM04	O-ring P4 FKM
455	319143-080	EZM06	O-ring P6 FKM
456	319143-100	EZM14	O-ring P14 FKM
457	319143-091	EZM15	O-ring P15 FKM
458	319143-083	EZM16	O-ring P16 FKM
459	319143-097	EKH30	Fastener "4-11"
460	319143-105	EKK24	Fastener "14-22"
461	319143-226	EM192	Fastener "16A"
462	319143-205	EKK39	Fastener "16-25A"
463	319143-112	EX12K	Fastener "6-15"
464	319143-535	EK217	Flat heater
465	319143-536	EK218	Drain pipe
466	319143-538	EK220	Cold pipe
467	319143-539	EK222	Stainless heat exchanger out pipe
468	319143-540	EK226	Header connection
469	319143-541	EK228	Drain port
470	319143-106	EX13H	Thermistor fixing plate
471	319143-111	EX13L	Exhaust thermistor gasket
472	319143-104	EKH6G	Hi-limit switch for exhaust
473	319143-542	EK229	Gasket
701	319143-545	EK176	Computer board
702	319143-334	EX00B	Rubber grommet
703	320273-128	EK280	Surge box
704	319143-427	EK146	120 VAC wire for Indoor models
	319143-546	EK143	120 VAC wire for Outdoor models
706	319143-141	EKK4V	120 VAC Power ON-OFF switch
707	319143-491	EK165	Remote controller wire
708	319143-492	EK168	Gas valve wire
709	319143-493	EK166	Flame rod wire
711	319143-479	EK153	Igniter assembly
713	319143-496	EK184	Switch wire with thermostat for Indoor models
	319143-497	EK185	Switch wire with thermostat for Outdoor models
714	319143-498	EK167	Proportional gas valve wire
715	319143-499	EK179	24V cables
716	319143-191	EKK1M	Computer board cover
717	319143-500	EX13C	Cable clamp for Indoor models
718	319143-131	EKH6E	Exhaust thermistor for Indoor models
719	319143-484	EK152	Remote fixing plate
721	319143-501	EK180	Exhaust Hi-limit switch wire
722	319143-502	EK173	Temperature controller for Indoor models
723	319143-503	EK178	Fixing plate
724	9009069005	TM-RE42	Temperature remote controller (Standard)
	9008172005	TM-RE40	Temperature remote controller (for high temperature mode)