

SERVICE GUIDE FOR STANDARD RESIDENTIAL FVIR GAS WATER HEATERS

MODELS: G/LORT, G/LORS, G/LBRT,
G/LBRS, G/LBCT, G/LBCS, G/LKRT, G/LKRS,
G/LKCT, G/LART, G/LARS, G/LXRT, G/LQRT –
SERIES 200/201 and SERIES 202/203

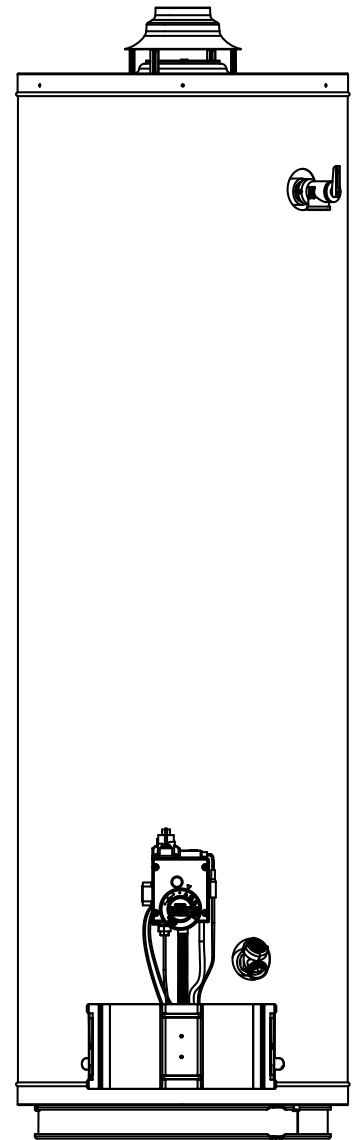

Water Heaters
Reliance[®]

SERVICE HANDBOOK

Your safety and the safety of others is extremely important in the servicing of this water heater. Many safety-related messages and instructions have been provided in this handbook and on your water heater to warn you and others of a potential hazard. Read and obey all safety messages and instructions throughout this handbook. It is very important that the meaning of each safety message is understood by you and others who service this water heater.

The information contained in this handbook is designed to answer commonly faced situations encountered in the operation of the standard Residential Gas product line and is not meant to be all-inclusive. If you are experiencing a problem not covered in this handbook, please contact the Technical Information Center listed on the cover of this handbook for further assistance. Additional information is also available on the web site listed on the cover of this handbook. This handbook is intended for use by licensed plumbing professionals and reference should be made to the Installation Instructions and Use & Care Guide accompanying the product. This handbook contains supplemental information to the Installation Instructions and Use & Care Guide.

When servicing residential water heaters, it is essential that you return the unit to a safe condition before you leave the site. All original components must be re-installed and all safety measures must be implemented. In addition, the recommended water temperature setting is 120° F.

IMPORTANT: It is recommend that on every service call an inspection & cleaning of the base ring filter and flame arrestor be performed. See page 19.

Tools Required (for servicing gas models):

- Phillips head screw driver
- 3/8, 7/16, & 3/4 inch open end wrenches
- 3/16 inch Allen wrench
- 11/16 inch – 6 point – socket – for anode removal
- electrical multimeter (with alligator leads)
- digital or analog manometer
- gas pressure gauge
- water pressure gauge
- thermometer
- tubing cutter if pilot tube is to be replaced
- hose – to drain tank
- container – to measure gallons per minute flow



Digital manometer shown.

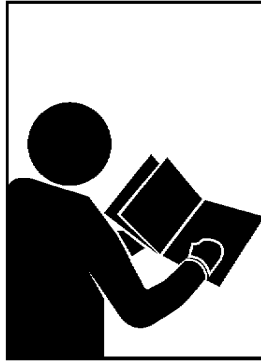

⚠️ WARNING

Read and understand instruction manual and safety messages before installing, operating or servicing this water heater.

Failure to follow instructions and safety messages could result in death or serious injury.

Instruction manual must remain with water heater.

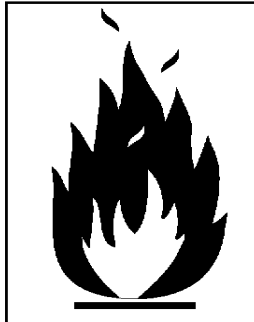

⚠️ WARNING

Fire Hazard

For continued protection against risk of fire:

- Do not install water heater on carpeted floor.
- Do not operate water heater if flood damaged.

⚠️ DANGER

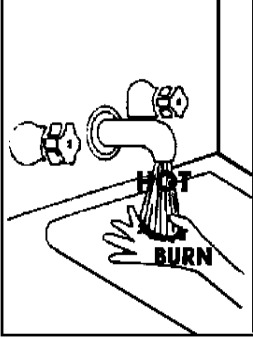

Water temperature over 125°F (52°C) can cause severe burns instantly resulting in severe injury or death.

Children, the elderly, and the physically or mentally disabled are at highest risk for scald injury.

Feel water before bathing or showering.

Temperature limiting valves are available.

Read instruction manual for safe temperature setting.

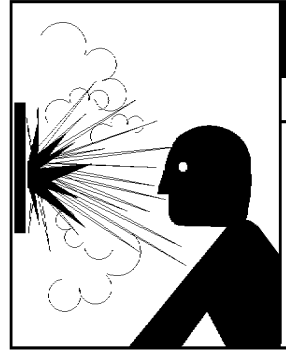

⚠️ WARNING

Explosion Hazard

- Overheated water can cause watertank explosion.
- Properly sized temperature and pressure relief valve must be installed in opening provided.

⚠️ WARNING

Fire or Explosion Harzard

- Do not store or use gasoline or other flammable vapors and liquids in the vicinity of this or any other appliance.
- Avoid all ignition sources if you smell Natural or LP gas.
- Do not expose water heater control to excessive gas pressure.
- Use only gas shown on rating plate.
- Maintain required clearances to combustibles.
- Keep ignition sources away from faucets after extended period of non-use.



Read instruction manual before installing, using or servicing water heater.



⚠️ WARNING

Breathing Hazard - Carbon Monoxide Gas



- Install vent system in accordance with codes.
- Do not operate water heater if flood damaged.
- High altitude orifice must be installed for operation above 7,700 feet (2,347m).
- Do not operate if soot is present.
- Do not obstruct water heater air intake with insulating jacket.
- Do not place chemical vapor emitting products near water heater.
- Gas and carbon monoxide detectors are available.

Breathing carbon monoxide can cause brain damage or death. Always read and understand instruction manual.

CAUTION

Improper installation and use may result in property damage.

- Do not operate water heater if flood damaged.
- Inspect and replace anode.
- Install in location with drainage.
- Fill tank with water before operation.
- Be alert for thermal expansion.

Refer to instruction manual for installation and service.

TROUBLESHOOTING QUICK REFERENCE

IMPORTANT: Before performing any test, check the area around the water heater for any source of a flammable vapor (i.e gasoline, paint thinners, etc.) If any sources are found do not proceed until they are removed.

PROBLEM	POSSIBLE CAUSE	TEST / CORRECTIVE ACTION
----------------	-----------------------	---------------------------------

NO HOT WATER:

Insufficient Combustion Air or Venting Issues – combustion chamber thermal cut off tripped.

Follow the steps on pp 18 – 19. Always check and clean the base ring filter and the flame arrestor.

Pilot will not light

Check gas supply/Bleed air from gas line/turn gas on.

Pilot will not remain lit when top gas control knob is released

Test thermocouple and gas control valve/ thermostat as described on pp 20-21.

Burner will not light or remain lit.

Low gas pressure – check as described on p 18. Insufficient combustion air – follow steps on pp 18 -19.

INSUFFICIENT HOT WATER:

Water heater improperly sized to meet hot water demands

Compare hot water requirements with the capacity of the water heater. See sizing guide on p. 25. You may also use the volume test on page 34 to analyze your hot water needs. If necessary, install a water heater with greater capacity.

Gas Control Valve/Thermostat set too low

Turn temperature dial to desired temperature as described on p. 24

Sediment or lime in the tank

Drain (p. 17). Determine if water treatment is needed (p. 29).

WATER LEAKAGE:

Condensation

Adjust the thermostat setting (p 24).

Dripping Temperature & Pressure Relief Valve

Check water supply pressure.

In closed systems, the supply pressure should not exceed 80 psi (in a 24 hour cycle). If the pressure exceeds 80 psi, install a pressure reducing valve in combination with a properly sized thermal expansion tank (pp. 35-36 & 37).

PROBLEM	POSSIBLE CAUSE	TEST / CORRECTIVE ACTION
----------------	-----------------------	---------------------------------

WATER LEAKAGE:

Thermostat does not shut-off

Check the Gas Control Valve/Thermostat as described on p. 20-21.

Drain valve dripping/leaking

Back flush to clean- out sediment, replace if necessary

Tank Leak

Check Leakage Checkpoints described on p. 25.

TABLE OF CONTENTS

BASIC INSTALLATION	8-16
DRAINING AND FILLING THE WATER HEATER.....	17
Draining the Water Heater	17
Filling the Water Heater	17
CHECKING THE GAS SUPPLY FOR PRESSURE.....	18
CHECKING FOR SUFFICIENT COMBUSTION AIR OR VENTING ISSUES	18-19
Combustion Air Test.....	18
Draft Test.....	19
External Inspection & Cleaning of the Base Ring Filter	19
Cleaning the Combustion Chamber and Flame Arrestor	19
TESTING THE THERMOCOUPLE AND GAS CONTROL VALVE/THERMOSTAT	20
Thermocouple Output Test.....	20
Gas Control Valve/Thermostat (Thermal Switch Models)	20
REPLACING THE THERMOCOUPLE AND GAS CONTROL VALVE/THERMOSTAT	21-23
Removing the Manifold/Burner Assembly	21
Removing the Burner from the Manifold/Burner Assembly	21
Replacing the Thermocouple	21
Replacing the Manifold/Burner Assembly	22
Removing and Replacing the Gas Control Valve/Thermostat.....	23
ADJUSTING THE TEMPERATURE ON THE GAS CONTROL VALVE/THERMOSTAT	24
GAS WATER HEATER SIZING GUIDE	25
LEAKAGE CHECKPOINTS.....	25
TECHNICAL SERVICE BULLETINS.....	26-38
Water Hammer.....	27
Mineral Buildup	28
Aluminum Hydroxide.....	29
Condensation.....	30
Discolored Water.....	31
Smelly Water.....	32
Chlorination Procedure	33
Not Enough Hot Water	34
Thermal Expansion	35-36
Leaking Temperature and Pressure Relief Valve.....	37
Insulation Blanket.....	38
GENERAL INFORMATION.....	39-40

BASIC INSTALLATION & OPERATION

INSTALLATION OF RESIDENTIAL GAS WATER HEATER

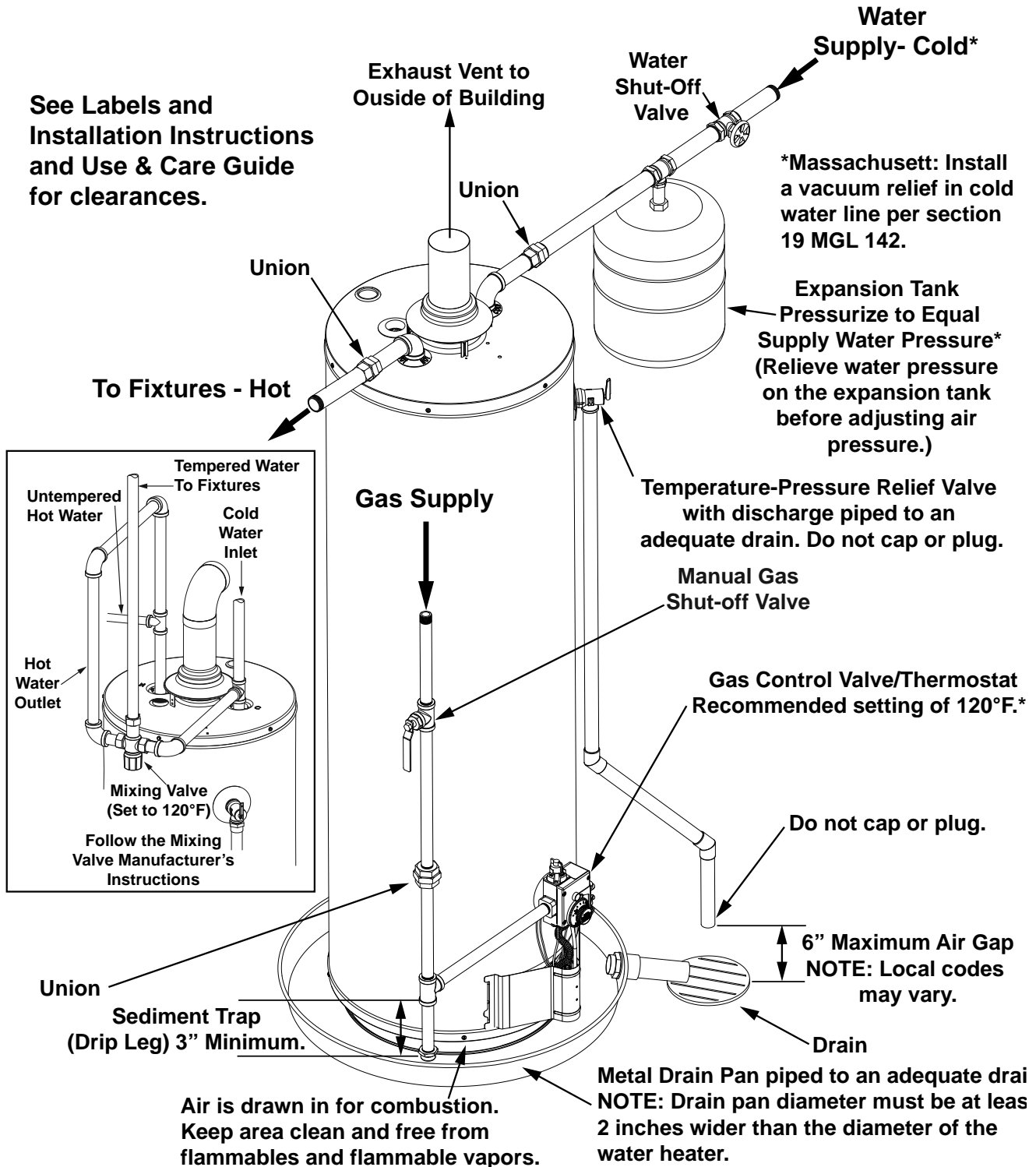

The water heater must be installed according to all local and state codes or in the absence of local and state codes, the "National Fuel Gas Code" ANSI Z223.1(NFPA 54)- current edition.

* NOTE: If on a well system the expansion tank should be set to the maximum pressure of the pump tank.

** White-Rodgers® gas control valve/thermostat shown in this figure. The valve may vary according to model and year.

Figure 1

BASIC INSTALLATION & OPERATION

This portion of this handbook applies to the Operations and Servicing of Residential Gas, Tank Type, Water Heaters, which are vented atmospherically and use a thermocouple as their electrical source.

Control: There are two gas control valve/thermostat configurations available. Both valves have similar control elements such as the Gas Control Knob & Water Temperature Dial. Both valves have high water temperature limit safety. Please note the location of the control elements on the following figures.

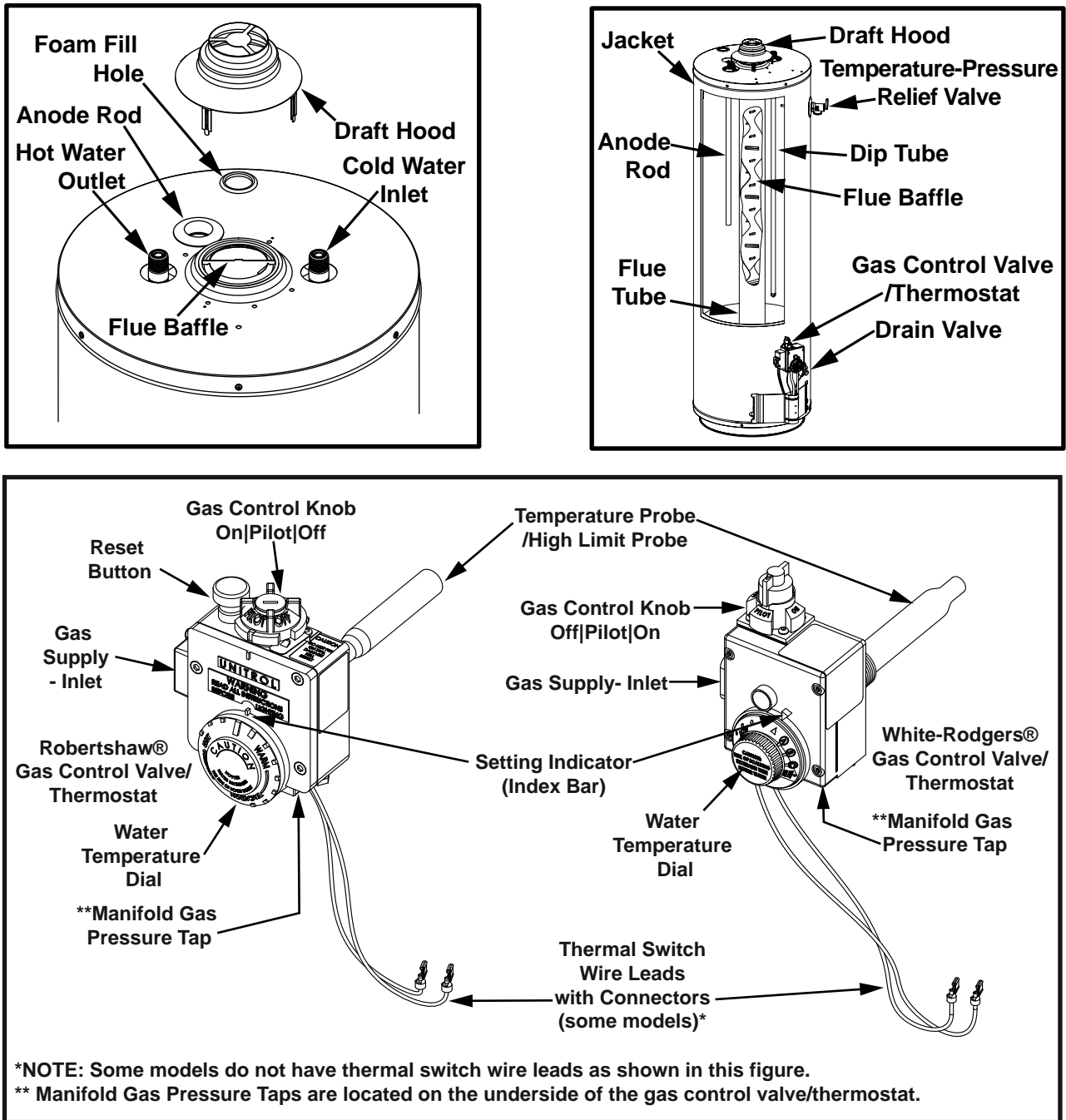
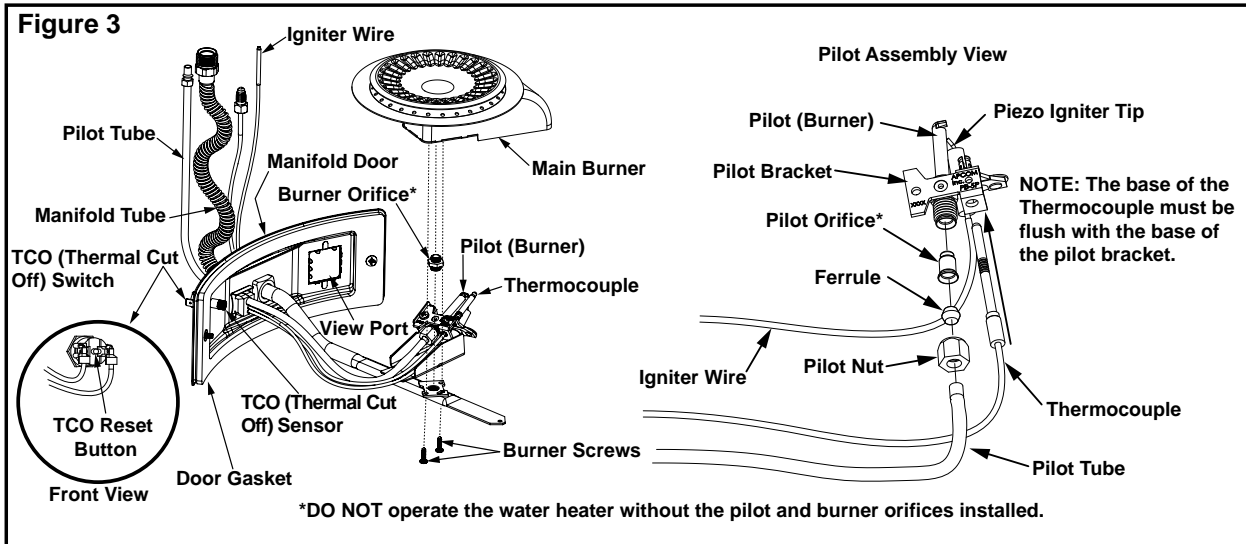

Figure 2

BASIC INSTALLATION & OPERATION

Burner/Manifold Door Assembly: The burner/manifold assembly consists of several components such as: main burner, burner orifice, manifold tube, pilot burner, pilot orifice, pilot tube, igniter, and thermocouple. See the figure below for the complete list of components.

The pilot burner remains on once it is manually lit. When incoming cold water activates the thermostat, gas flows to the main burner. The pilot flame ignites this gas. The main flame burns until the tank reaches set temperature then the thermostat interrupts this main gas flow.



Normal Operation

Pilot: The pilot flame heats the end of a thermocouple. As the thermocouple gets hotter, it generates a small (cannot be detected without an electrical meter) electrical current to the bottom of the gas control valve/thermostat. This current powers the electromagnet and holds open the main gas interrupter as long as the pilot flame is heating the thermocouple. The normal voltage for a properly working thermocouple is between 20 and 30 mv. **DANGER!** If the pilot is extinguished, it can take up to 180 seconds for the thermocouple to cool sufficiently to close the safety valve.

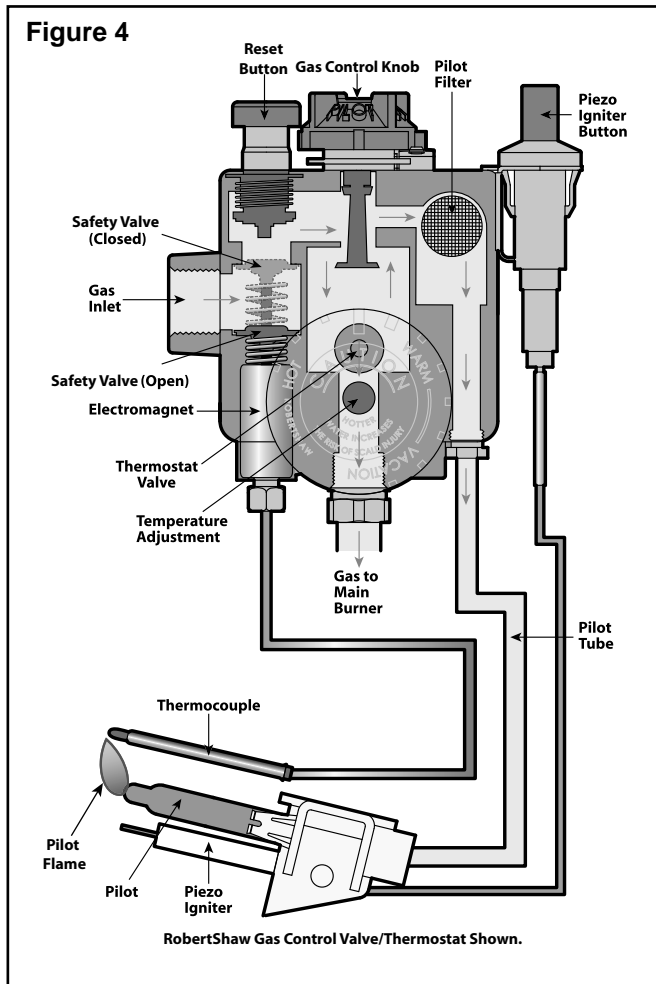

BASIC INSTALLATION & OPERATION

Energy Cut Off (ECO): A metal tube (Temperature Probe) mounted onto the back of the gas control valve/thermostat is immersed inside the tank water. The probe acts as a temperature high limit. If water gets excessively hot, an Energy Cut Off (ECO) switch within the probe opens, interrupting the small electrical current to the gas valve, and gas flow through the control is interrupted. NOTE: If this safety sensor opens, the entire control must be replaced. The ECO is NOT resettable.

Thermal Cut Off Switch (TCO): The water heater is also equipped with a resettable thermal switch, designed to shut off the gas supply in the event the water heater has been exposed to high combustion chamber temperatures caused by flammable vapors (e.g. spilled gasoline), poor combustion caused by a blocked vent or insufficient combustion air.

Gas: When you prepare to light the pilot, you are instructed to turn the gas control knob to the pilot position and depress the gas control knob (Reset button on Robertshaw Gas Valves). When depressed gas will flow to the pilot burner only. You then have to (manually) ignite this pilot gas using the piezo igniter button. When the pilot is lit, the flame must heat the thermocouple until it generates sufficient voltage to the gas valve to allow you to release the knob while gas continues to flow to the pilot. When the gas control knob is turned to the "ON" position, gas is also available to the main burner if the thermostat calls for heat.

Water Flow: When a hot water faucet is opened, water pressure from the well tank or street main forces cold water into the water heater through the dip tube. This pushes hot water out of the tank.

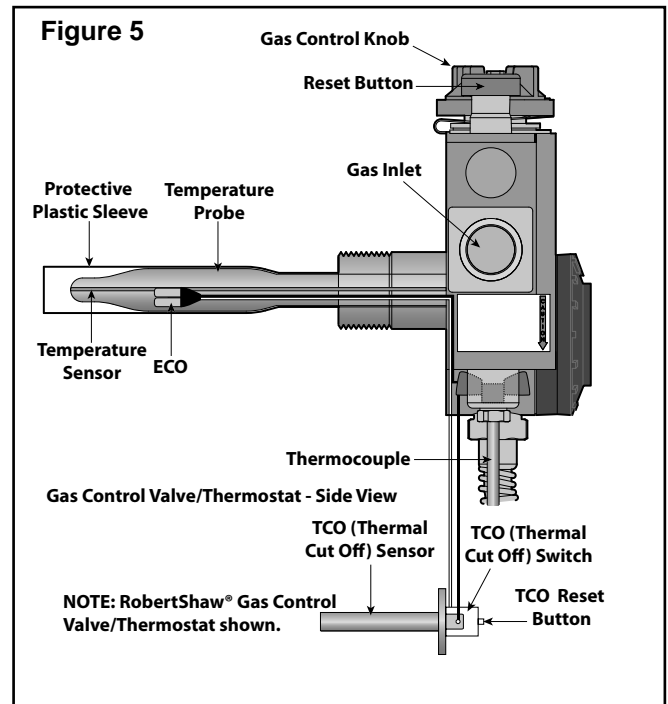

BASIC INSTALLATION & OPERATION

Thermostat Operation: Standard residential water heaters use mechanical thermostats. With a mechanical thermostat, a dial setting of 120° F may shut the burner down at a tank temperature between 110° and 130° F. The heater will consistently shut off at this same temperature. For this same reason, water temperature may drop 15° F - 25° F, around the temperature probe, before the main burner is activated. Keep in mind that hot water in the upper part of the tank will probably be very near the “shut off” temperature of the control while incoming cold water drops the water temperature around the thermostat probe. Also short, repeating heating cycles caused by small hot water uses can cause temperatures at the point of use to exceed the thermostat setting by up to 30° F.

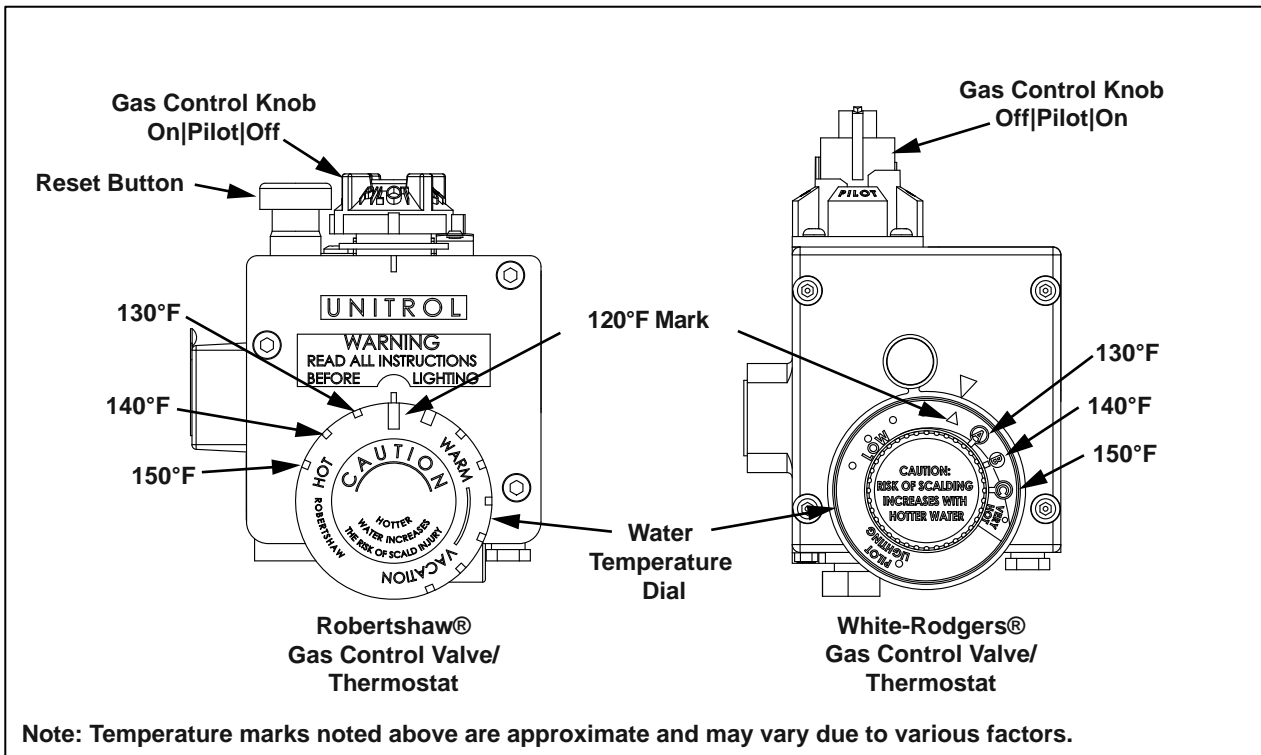

Water Temperature	Time to Produce 2nd & 3rd Degree Burns on Adult Skin
160°F (71°C)	About 1/2 second
150°F (66°C)	About 1-1/2 seconds
140°F (60°C)	Less than 5 seconds
130°F (54°C)	About 30 seconds
120°F (49°C)	More than 5 minutes
80°F (27°C)	-----

Figure 6

BASIC INSTALLATION & OPERATION

Combustion Air Requirements:

⚠ WARNING

Carbon Monoxide Warning

Water heater must be vented to outdoors.

Vent must be installed by a qualified technician using the local and state codes or, in the absence of local and state codes, the National Fuel Gas Code, ANSI Z223.1 (NFPA 54) - current edition, and/or the installation instructions.

Examples of a qualified technician include: gas technicians, authorized gas company personnel, and authorized service persons.

Failure to so do can result in death or carbon monoxide poisoning.

IMPORTANT: Air for combustion and ventilation must not come from a flammable or corrosive atmosphere. Any failure due to flammable or corrosive elements in the atmosphere is excluded from warranty coverage.

The following types of installation (not limited to the following) will require outdoor air for combustion due to chemical exposure and may reduce but not eliminate the presence of corrosive chemicals in the air:

- beauty shops
- photo processing labs
- buildings with indoor pools
- water heaters installed in laundry, hobby, or craft rooms
- water heaters installed near chemical storage areas
- water softeners

Combustion air must be free of acid-forming chemicals such as sulfur, fluorine, and chlorine. These elements are found in aerosol sprays, detergents, bleaches, cleaning solvents, air fresheners, paint, and varnish removers, refrigerants, and many other commercial and household products. When burned, vapors from these products form highly corrosive acid compounds. These products should not be stored or used near the water heater, air inlet, or air intake path.

Combustion and ventilation air requirements are determined by the location of the water heater. The water heater may be located in either an open (unconfined) area or in a confined area or small enclosure such as a closet or small room. Confined spaces are areas with less than 50 cubic feet for each 1,000 BTUH of the total input for all gas-using appliances.

Unconfined Space: A water heater in an unconfined space uses indoor air for combustion and requires at least 50 cubic feet for each 1,000 BTUH of the total input for all gas appliances. The table below shows a few examples of the minimum square footage (area) required for various BTUH inputs.

BTUH Input	Minimum Square Feet with 8' Ceiling	Typical Room with 8' Ceiling
30,000	188	9 x 21
45,000	281	14 x 20
60,000	375	15 x 25
75,000	469	15 x 31
90,000	563	20 x 28
105,000	657	20 x 33
120,000	750	25 x 30
135,000	844	28 x 30

IMPORTANT:

- The area must be open and be able to provide the proper air requirements to the water heater. Areas that are being used for storage or contain large objects may not be suitable for water heater installation.
- Water heaters installed in open spaces in buildings with unusually tight construction may still require outdoor air to function properly. In this situation, outside air openings should be sized the same as for a confined space.
- Modern home construction usually requires supplying outside air into the water heater area.
- Room exhaust fans may effect air requirements.

Confined Space: For the correct and proper operation of this water heater, ample air must be supplied for the combustion, ventilation, and dilution of flue gases. Small enclosures and confined areas must have two permanent openings so that sufficient fresh air can be drawn from outside of the enclosure. One opening shall be within 12 inches of the top and one within 12 inches of the bottom of the enclosure.

The size of each opening (free area) is determined by the total BTUH input of all gas utilization equipment (i.e., water heaters, furnaces, clothes dryers, etc.) and the method by which the air is provided. The BTUH input can be found on the water heater rating plate. Additional air can be provided by two methods:

1. All air from inside the building.
2. All air from outdoors.

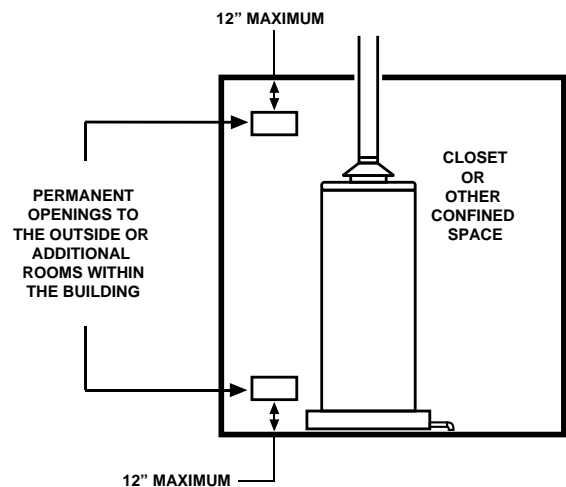

Figure 7

BASIC INSTALLATION & OPERATION

All Air from Inside the Building: When additional air is to be provided to the confined area from additional room(s) within the building, the total volume of the room(s) must be of sufficient size to properly provide the necessary amount of fresh air to the water heater and other gas utilization equipment in the area. Each of the two openings shall have a minimum free area of 1 square inch per 1,000 BTUH of the total input rating of all gas utilization equipment in the confined area, but not less than 100 square inches for each opening.

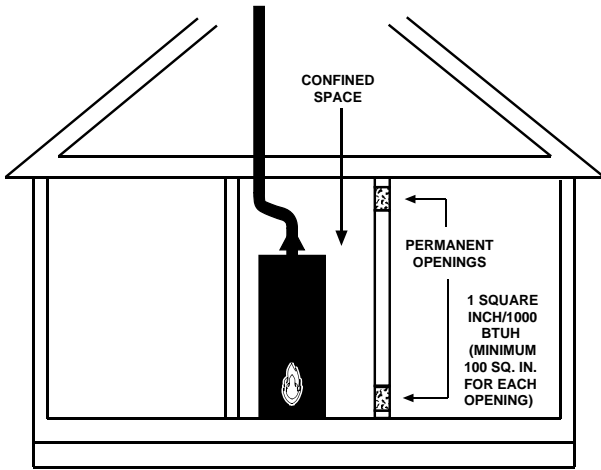

Figure 8

All Air from Outdoors: Outdoor fresh air can be provided to a confined area either directly or by the use of vertical and horizontal ducts. The fresh air can be taken from the outdoors or from crawl or attic spaces that freely communicate with the outdoors. Attic or crawl spaces cannot be closed and must be properly ventilated to the outside.

Ductwork must be of the same cross-sectional area as the free area of the opening to which they connect. The minimum dimension of rectangular air ducts cannot be less than three inches.

The size of each of the two openings is determined by the method in which the air is to be provided. Refer to the table below to calculate the minimum free area for each opening.

Louvers and Grilles: In calculating free area for ventilation and combustion air supply openings, consideration must be given to the blocking effect of protection louvers, grilles, and screens. These devices can reduce airflow, which in turn may require larger openings to achieve the required minimum free area. Screens must not be smaller than 1/4" mesh. If the free area through a particular design of louver or grille is known, it should be used in calculating the specified free area of the opening. If the design and free area are not known, it can be assumed that most wood louvers will allow 20 - 25% of free area while metal louvers and grilles will allow 60 - 75% of free area. Louvers and grilles must be locked open or interconnected with the equipment so that they are opened automatically during equipment operation. Keep louvers and grilles clean and free of debris or other obstructions.

Minimum Free Area of Permanent Openings for Ventilation and Combustion Air Supply - All Air from Outdoors Only.

Based on total BTUH input rating for all utilizing equipment within the confined space.

Opening Source	Minimum Free Area Per Opening (sq. in.)	Reference Drawing
*Direct to outdoors	1 sq. in. per 4000 BTUH	Figure 9
Vertical Ducts	1 sq. in. per 4000 BTUH	Figure 10
Horizontal Ducts	1 sq. in. per 2000 BTUH	Figure 11
Single Opening	1 sq. in. per 3000 BTUH	Figure 12

Example: A water heater with an input rating of 50,000 BTUH using horizontal ducts would require each opening to have a minimum free area of 25 square inches.

Minimum free area = 50,000 BTUH x 1 sq. in. / 2000 BTUH = 25 sq. in.

* These openings connect directly with the outdoors through a ventilated attic, a ventilated crawl space, or through an outside wall.

Consult the local codes of your area for specific ventilation and combustion air requirements

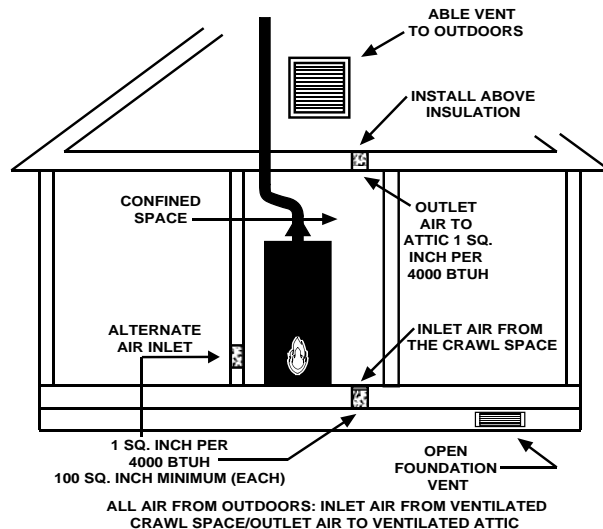

Figure 9

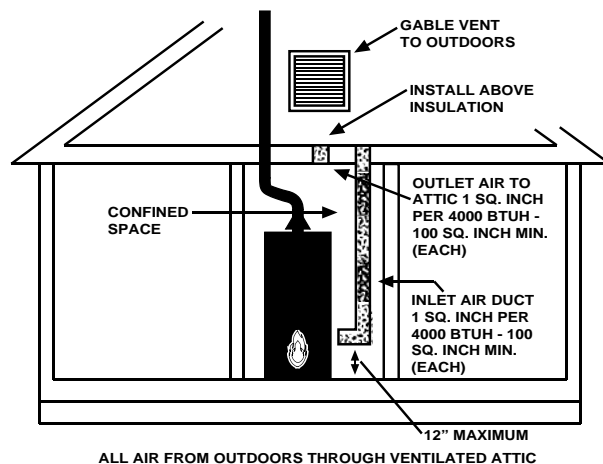

Figure 10

BASIC INSTALLATION & OPERATION

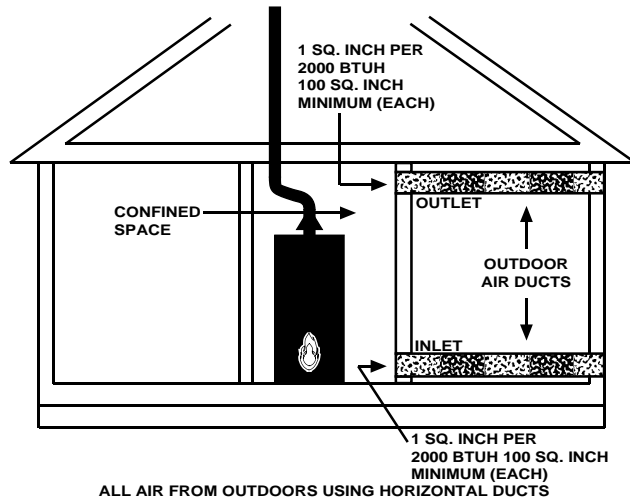

Figure 11

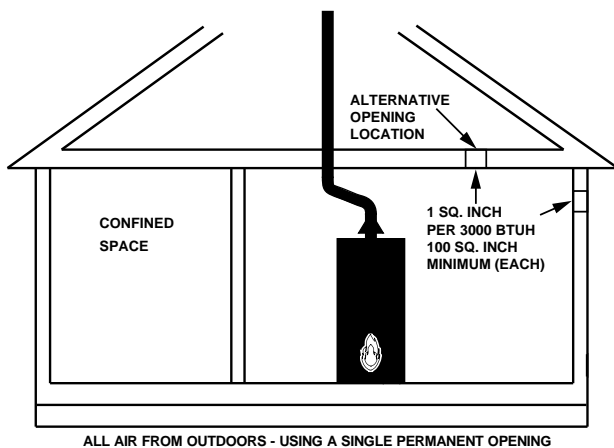

Figure 12

Vent Pipe System: This water heater must be properly vented for the removal of exhaust gases to the outside atmosphere. Correct installation of the vent pipe system is mandatory for the proper and efficient operation of this water heater and is an important factor in the life of the unit.

The vent pipe must be installed according to all local and state codes or, in the absence of local and state codes, the "National Fuel Gas Code", ANSI Z223.1(NFPA 54)-current edition. The vent pipe installation must not be obstructed so as to prevent the removal of exhaust gases to the outside atmosphere.

U.L. recognized fuel gas and carbon monoxide (CO) detectors are recommended in all applications and should be installed using the manufacturer's instructions and local codes, rules, or regulations.

Vent Pipe Size: It is important that you follow the guidelines in these instructions for sizing a vent pipe system. If a transition to a larger vent size is required, the vent transition connection must be made at the draft hood outlet. DO NOT reduce the vent size to less than the draft hood outlet diameter.

Vent Connectors:

1. Type B, Double wall, U.L. Listed Vent Pipe.
2. Single wall Vent Pipe.

Maintain the manufacturer's specified minimum clearance from combustible materials when using type B double wall vent pipe.

Vent connectors made of type B, double wall vent pipe material may pass through walls or partitions constructed of combustible material if the minimum listed clearance is maintained.

Maintain a one inch minimum clearance from all combustible materials when using single wall vent pipe.

IMPORTANT: Single wall vent pipe cannot be used for water heaters located in attics and may not pass through attic spaces, crawl spaces or any confined or inaccessible location. A single wall metal vent connector cannot pass through any interior wall.

When installing a vent connector, please note the following

- Install the vent connector avoiding unnecessary bends, which create resistance to the flow of vent gases.
- Install without dips or sags with an upward slope of at least 1/4-inch per foot.
- Joints must be fastened by sheet metal screws or other approved means. It must be supported to maintain clearances and prevent separation of joints and damage.
- The length of the vent connector cannot exceed 75% of the vertical vent height.
- The vent connector must be accessible for cleaning, inspection, and replacement.
- Vent connectors cannot pass through any ceiling, floor, firewall, or fire partition.
- It is recommended (but not mandatory) that a minimum 12 inches of vertical vent pipe be installed on the draft hood prior to any elbow in the vent system.

IMPORTANT: Existing vent systems must be inspected for obstructions, corrosion, and proper installation.

Chimney Connection: IMPORTANT: Before connecting a gas vent to a chimney, make sure the chimney passageway is clear and free of obstructions. The chimney must be cleaned if previously used for venting solid fuel appliances or fireplaces. Also consult local and state codes for proper chimney sizing and application or, in the absence of local and state codes, the "National Fuel Gas Code", ANSI Z223.1(NFPA 54)-current edition.

- The connector must be installed above the extreme bottom of the chimney to prevent potentially blocking the flue gases.

DRAINING AND FILLING THE WATER HEATER

Draining the Water Heater

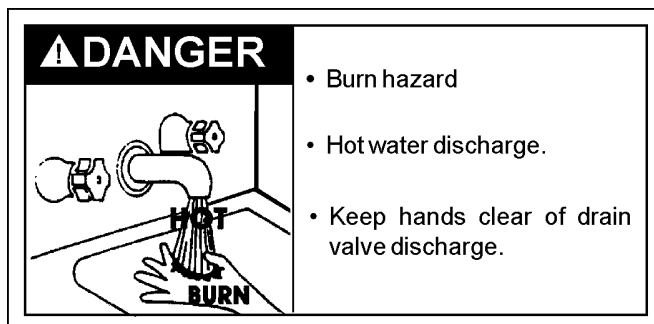

The water heater should be drained if being shut down during freezing temperatures. Also, periodic draining and cleaning of sediment from the tank may be necessary.

1. Turn off the gas to the water heater at the manual gas shut-off valve.
2. Open a nearby hot water faucet until the water is no longer hot.
3. Close the cold water inlet valve.
4. Connect a hose to the drain valve and terminate it to an adequate drain or external to the building. (Make sure all connections are tight and that the water flow is directed away from people.)
5. Open the water heater drain valve and allow all the water to drain from the tank. Flush the tank with water as needed to remove sediment.
6. Close the drain valve, refill the tank, and restart the heater as directed by the lighting instructions on the front of the water heater.

If the water heater is going to be shut down for an extended period, the drain valve should be left open.

IMPORTANT: Condensation may occur when the cold tank is first heated and should not be confused with a tank leak.

Filling the Water Heater



Never use this water heater unless it is completely full of water. To prevent damage, the tank must be filled with water. Water must flow from the hot water faucet before lighting the water heater. **NOTE:** The hot water faucet used should be the one furthest from the water heater.

To fill the water heater with water:

1. Close the water heater drain valve.
2. Open the cold water supply shut off valve to the water heater.
3. To ensure complete filling of the tank, allow air to exit by opening the furthest hot water faucet. Allow water to run until a constant flow is obtained. This will let air out of the water heater and the piping.
4. Check all new water piping for leaks. Repair as needed.

CHECKING THE GAS SUPPLY PRESSURE

Checking the Gas Supply Pressure

Gas pressure checks are done with flowing gas using a gas pressure gauge capable of reading pressure in inches of water column.

- Supply gas pressure checks are measured before the gas control valve/thermostat and as close to the water heater as possible.
- Manifold (main burner) gas pressure is measured at the pressure tap on the bottom of the gas control valve/thermostat. Use an Allen wrench to remove the plug then attach the gas gauge.

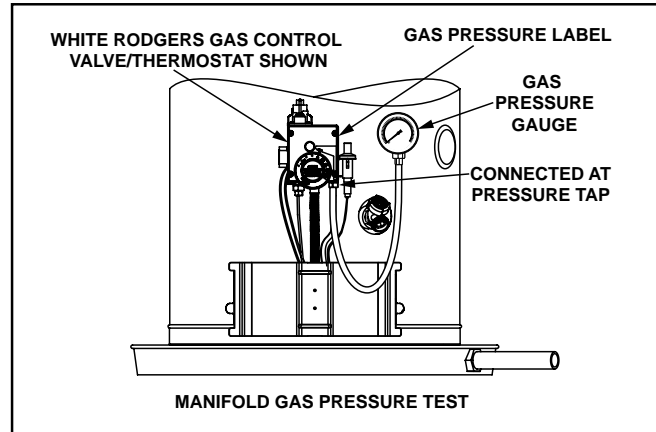

Figure 16

NOTE: Desired gas pressures will be noted on the gas valve label located on the gas control valve/thermostat.

IF THEN
supply gas pressure is under desired pressure requirement	<ul style="list-style-type: none"> • increase supply gas pressure regulator setting and, • increase supply gas piping size.
supply gas pressure is over desired pressure	<ul style="list-style-type: none"> • add gas pressure regulator. • reduce setting on existing regulator.
manifold gas pressure is more than +/- .3 inch W.C. from values indicated on gas valve	<ul style="list-style-type: none"> • ensure there is adequate supply gas pressure • ensure the main burner orifice is the correct size for the water heater model being tested. • if the above tests have been performed and the results were correct replace the gas control valve.

CHECKING FOR SUFFICIENT COMBUSTION AIR OR VENTING ISSUES

Combustion Air Test

The Installation Instructions and Use & Care Guide gives guidelines under "Air Requirements" and "Unconfined " or "Confined Space" sections. If you want to test for a lack of air:

1. Turn on every appliance and fan that exhausts air from the utility room and/or house. Make sure all windows and doors are closed, as well as chimney dampers.
2. Open a hot water faucet so that the main burner will ignite
3. Remove the outer door of the water heater – not the inner door
4. Monitor the flame characteristics for several minutes

If the flame begins to "yellow" open a door or window, to the outdoors, to see if additional air corrects this back to blue. If it does, the room needs more air supply.

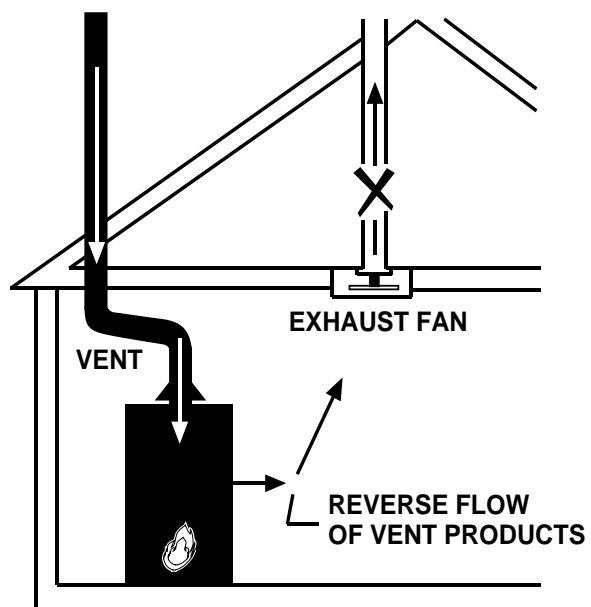

Figure 17

CHECKING FOR SUFFICIENT COMBUSTION AIR OR VENTING ISSUES

Draft Test

After successfully lighting the water heater, allow the unit to operate for 15 minutes and check the draft hood relief opening for proper draft. Make sure all other appliances in the area are operating and all doors/windows are closed when performing the draft test. Pass a match flame or smoke around the relief opening of the draft hood. A steady flame or smoke drawn into the opening indicates proper draft.

If the flame flutters or is blown out, combustion products are escaping from the relief opening. If this occurs, do not operate the water heater until proper adjustments or repairs are made to the vent pipe system and/or air supply requirements.

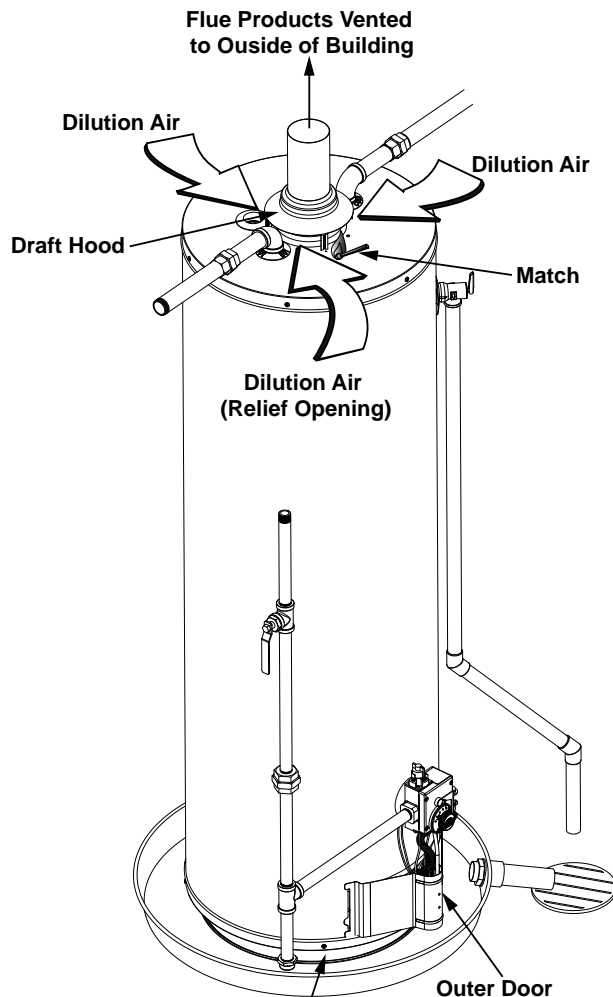

Air is drawn in for combustion.
Keep area clean and free from
combustibles and flammable vapors.

Figure 18

External Inspection & Cleaning of the Base-Ring Filter

1. At least annually check the base-ring filter for any dust or debris that may have accumulated on the filter screen. NOTE: If the water heater is located in an area that is subjected to lint and dirt, it may be necessary to check the base-ring filter more frequently.
2. Follow the Lighting Instructions to turn off the water heater and allow it to cool for 10 minutes before attempting to clean the base-ring filter.
3. Use a vacuum cleaner with a hose attachment to remove any dust or debris that may have accumulated on the filter. NOTE: If unable to inspect or clean the base-ring filter, follow the "Cleaning the Combustion Chamber and Flame-arrestor" instructions below.
4. After the base-ring filter has been cleaned, follow the Lighting Instructions to return the water heater to service.

Cleaning the Combustion Chamber and Flame-arrestor

1. Follow procedure outlined in "Removing the Manifold/Burner Assembly" (See page 22).
2. Use a vacuum cleaner/shop vac to remove all loose debris in the combustion chamber. Use compressed air to clear any dust or debris that may have accumulated in the flame-arrestor.

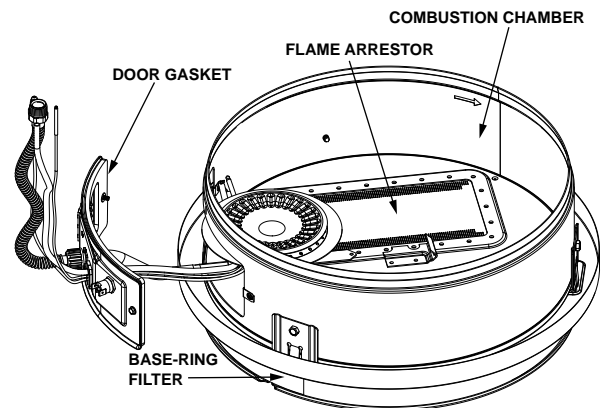

Figure 19

3. Reassemble following the procedure under "Replacing the Manifold/Burner Assembly" (See page 21).

TESTING THE THERMOCOUPLE AND GAS CONTROL VALVE/THERMOSTAT

IMPORTANT: Before performing any test, check the area around the water heater for any source of a Flammable Vapor (i.e gasoline, paint thinners, etc.) If any sources are found do not proceed until they are removed.

Thermocouple Output Test

The following test will check the DC voltage generated by the thermocouple when the pilot light is lit.

1. Disconnect the thermocouple from the gas control valve/thermostat as shown in the adjacent figure.
2. Using a multimeter with alligator clips leads, attach the red lead to the body (copper part) of the thermocouple. Attach the black lead to the end (silver part) of the thermocouple. Reference the adjacent image for placement of the leads.
3. Follow the lighting instructions on the front of the water heater to light the pilot and watch the voltage readings on the multimeter. NOTE: You will have to hold the button down to keep the pilot lit for the duration of the test. After 45 seconds the meter should read 20-30 millivolts DC or more.

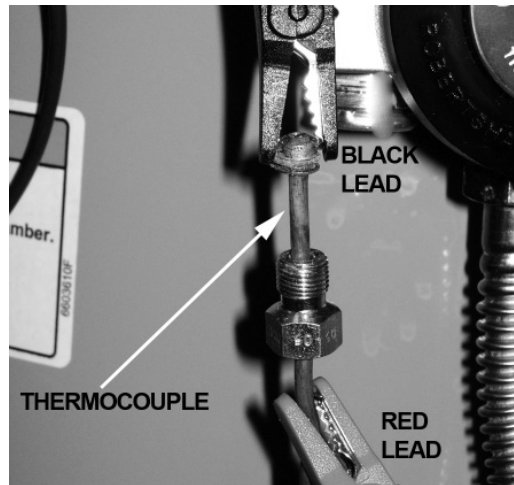

Figure 20

IF THEN
the multimeter voltage reads at least 20-30 millivolts DC	<ul style="list-style-type: none"> • check the positioning of the thermocouple tip to the pilot flame. If necessary position the thermocouple to ensure the flame contacts the thermocouple's tip. Re-test the thermocouple, and if it fails replace the thermocouple. (See p. 22)
the multimeter voltage reads more than 20-30 millivolts DC	<ul style="list-style-type: none"> • the thermocouple is working properly. Proceed to the gas control valve/thermostat test.

Gas Control Valve/Thermostat Test

(Thermal Switch Models)

The following test will check the gas control valve/thermostat's ECO & TCO (Energy Cut Off & Thermal Cut Off). NOTE: This test applies to gas valves with wire leads that attach to the thermal switch on the manifold door.

1. Remove both wire leads from the TCO (thermal cut off switch) and jumper the two leads to complete the circuit. Once the test is complete, remove the jumper and reconnect the wire leads.
2. Follow the lighting instructions on the front of the water heater to light the pilot.
3. Release the knob and check to see if the pilot remains lit.

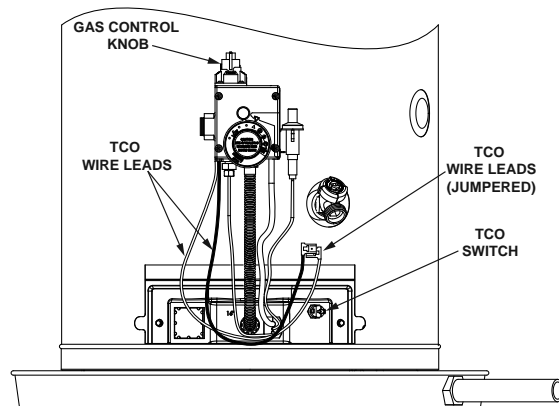

Figure 21

IF THEN
the pilot lights and remains lit	<ul style="list-style-type: none"> • the TCO (thermal switch sensor) has tripped OR the TCO is not working (OPEN). Reattach the wire leads and press the TCO reset button. Relight the water heater. If the pilot will not remain lit, replace the TCO. If the pilot does remain lit, the TCO was tripped-possibly due to a lack of combustion air (see pp 13-16 & 18-19) OR because of a Flammable Vapor event. Check around the water heater for any source of flammable vapors (i.e. gasoline, paint thinner, etc.).
the pilot will not light or remain lit with the wire leads jumpered	<ul style="list-style-type: none"> • replace the gas control valve/thermostat. (See p. 24)

REPLACING THE THERMOCOUPLE AND GAS CONTROL VALVE/THERMOSTAT

Removing the Manifold/Burner Assembly

1. Turn off the gas supply to the water heater at the manual gas shut-off valve. This valve is typically located beside the water heater. Note the position of the shut-off valve in the open/on position then proceed to turn it off.
2. On the lower front of the water heater locate the gas control valve/thermostat. Before performing any maintenance, it is important to turn the temperature dial on the gas control valve/thermostat to its lowest setting.
3. On top of the gas control valve/thermostat turn the gas control knob to the "OFF" position. NOTE: On the White-Rodgers® gas control valve/thermostat the knob stop must first be depressed before turning the gas control knob. See Lighting Instructions on the water heater.

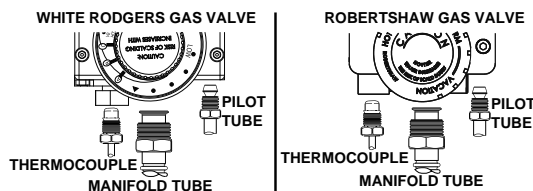

Figure 22

4. Remove the outer door.
5. Remove the two screws securing the manifold door assembly to the combustion chamber.

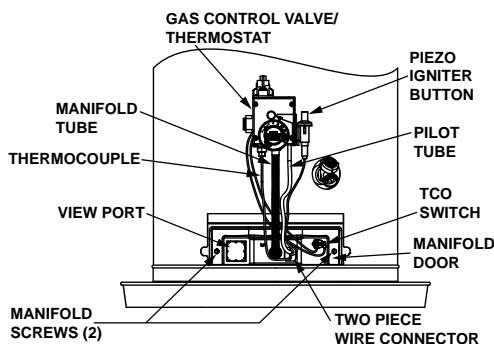

Figure 23

6. Disconnect the thermocouple (right-hand thread), pilot tube, the igniter wire from the igniter button, the two connectors attached to the TCO switch, and manifold tube at the gas control valve/thermostat. NOTE: L.P. Gas systems use reverse (left-hand) threads on the manifold tube.
7. Grasp the manifold tube and push down slightly to free the manifold, pilot tube, and thermocouple.
8. Carefully remove the manifold/burner assembly from the burner compartment. NOTE: Be sure not to damage internal parts.

Removing the Burner from the Manifold/Burner Assembly

Natural Gas (Low Nox) & L.P. Gas Burner

1. Take off the burner by removing the two (2) screws located underneath the burner.
2. Check the burner to see if it is dirty or clogged. The burner may be cleaned with soap and hot water.

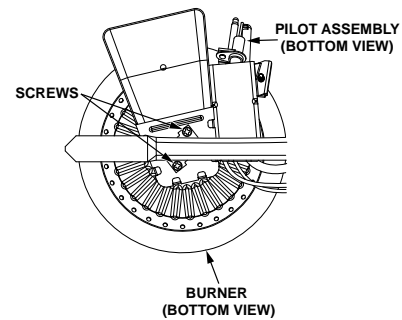

Figure 24

Replacing the Thermocouple

1. Remove the manifold/burner assembly as directed previously.
2. Lift the retainer clip straight up from the back of the two piece wire connector (using a flat-blade screwdriver), then remove the two piece wire connector from the manifold door.
3. Remove the burner, see Removing the Burner from the Manifold/Burner Assembly.
4. Pull the thermocouple from the pilot assembly.

IMPORTANT: Be careful not to bend or alter the position of the pilot assembly components.

5. Insert the thermocouple tip into the holes provided in the pilot bracket until it clicks into place. NOTE: The base of the thermocouple must be flush with the base of the pilot bracket.
6. Position the new thermocouple through the bottom opening of the two piece wire connector. Be sure igniter wire is positioned through the middle opening of the two piece wire connector.
7. Re-attach the burner. Note the orientation of the burner.
8. See Replacing the Manifold/Burner Assembly.

REPLACING THE THERMOCOUPLE AND GAS CONTROL VALVE/THERMOSTAT

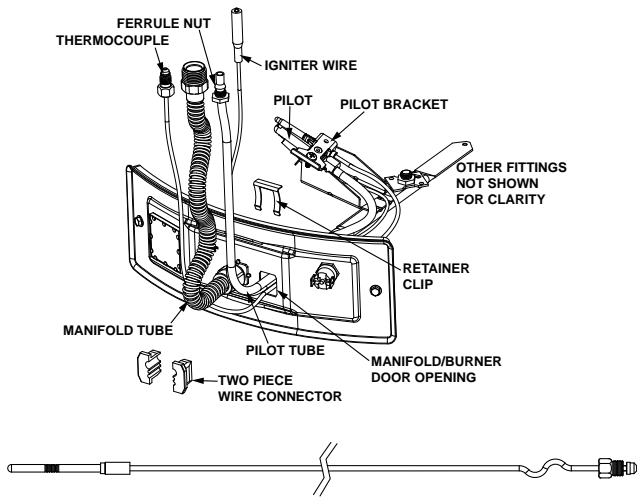

Figure 25

Replacing the Manifold/Burner Assembly

⚠ WARNING



Explosion Hazard

- Tighten both manifold door screws securely.
- Remove any fiberglass between gasket and combustion chamber.
- Replace viewport if glass is missing or damaged.
- Replace two piece wire tube connector if missing or removed.
- Replace door gasket if damaged.
- Failure to follow these instructions can result in death, explosion, or fire.

1. Check the door gasket for damage or imbedded debris prior to installation.
2. Inspect the view port for damage and replace as required.
3. Insert the manifold/burner assembly into the burner compartment making sure that the tip of the manifold tube engages in the slot of the bracket inside the combustion chamber (Figures 32 & 33).
4. Inspect the door gasket and make sure there is no fiberglass insulation between the gasket and the combustion chamber.

5. Replace the two screws, which secure the manifold/burner assembly door to the combustion chamber and tighten securely. Once the manifold/burner assembly door is tightened, visually inspect the door gasket between the manifold/burner assembly door and the combustion chamber for spaces or gaps that would prevent a seal. **IMPORTANT:** Do not operate the water heater if the door gasket does not create a seal between the manifold door and the combustion chamber.
6. During the following procedure, do not cross-thread or apply any thread sealant to any of the fittings listed below. First, reconnect the manifold tubing to the gas control valve/thermostat. **NOTE:** L.P. gas systems use reverse (left-hand) threads on the manifold tube.

NOTE: If a ferrule nut needs to be installed for the pilot tube, locate the one provided with your parts kit. Install it in the gas control valve/thermostat at the pilot location, hand tight only. Next, insert the pilot tube into the ferrule nut until it bottoms out. **NOTE:** Hold the tube in this position. Tighten the ferrule nut with a wrench until the crimp connection seals to the pilot tube. Continue to tighten until the nut is tight in the gas control valve/thermostat. Finally, start the thermocouple nut and turn it all the way in by hand. An additional quarter turn with a 3/8" open-end wrench will then be sufficient to seat the lockwasher. When you are finished, connect the two wire leads that go to the thermal switch.

7. Reconnect the igniter wire.
8. Turn gas supply on and refer to the Lighting Instructions.
9. With the burner lit, check the gas control valve/thermostat supply line, two piece wire connector, manifold tube, and pilot tube connections for leaks. Check for leaks by brushing on an approved noncorrosive leak detection solution. Bubbles forming indicate a leak. Correct any leak found. **IMPORTANT:** All leaks must be fixed immediately.
10. Replace the outer door.

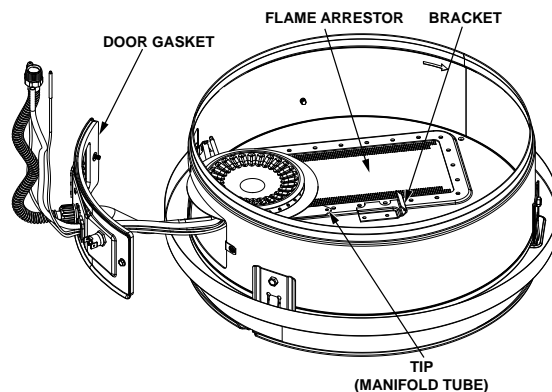

Figure 26

REPLACING THE THERMOCOUPLE AND GAS CONTROL VALVE/THERMOSTAT

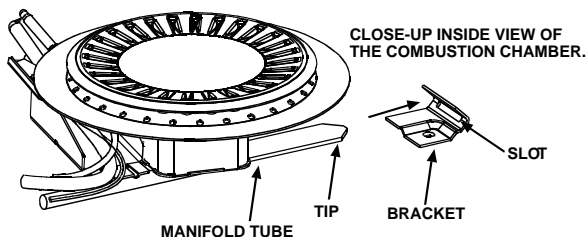

Figure 27

Removing and Replacing the Gas Control Valve/Thermostat

IMPORTANT: This water heater has a resettable thermal switch installed. Do not attempt to disable or modify this feature in any way. Use only factory authorized replacement parts.

Removing the Gas Valve:

1. Turn off the gas supply to the water heater at the manual gas shut-off valve. This valve is typically located beside the water heater. Note the position of the shut-off valve in the open/on position then proceed to turn it off.
2. On the lower front of the water heater locate the gas control valve/thermostat. Before performing any maintenance, it is important to turn the temperature dial on the gas control valve/thermostat to its lowest setting.
3. On top of the gas control valve/thermostat turn the gas control knob to the "OFF" position. NOTE: On the White-Rodgers® gas control valve/thermostat the knob stop must first be depressed before turning the gas control knob. See Lighting Instructions on the water heater.
4. Drain the water heater. Refer to the section of "Draining and Flushing" section and follow the procedure.
5. Disconnect the piezo igniter wire from the piezo igniter button. NOTE: There are two types of igniters. If you have the square igniter, slide the igniter bracket backwards away from the gas valve to remove it. If you have the round igniter, first remove the igniter from the bracket by depressing front and rear holding tabs and lift. Next remove igniter bracket from the gas valve. Disconnect the thermocouple, pilot tube, the two connectors attached to the thermal switch, and manifold tube at the gas control valve/thermostat. NOTE: L.P. gas systems use reverse (left-hand) threads on the manifold tube.
6. Refer to "Gas Piping" section and disconnect the ground joint union in the gas piping. Disconnect the remaining pipe from the gas control valve/thermostat.
7. To remove the gas control valve/thermostat, thread a correctly sized pipe into the inlet and use it to turn the gas control valve/thermostat (counterclockwise.) Do not use pipe wrench or equivalent to grip body. Damage may result, causing leaks.

Do not insert any sharp objects into the inlet or outlet connections. Damage to the gas control valve/thermostat may result.

Replacing the Gas Valve:

1. To replace the gas control valve/thermostat, reassemble in reverse order. When replacing the gas control valve/ thermostat, thread a correctly sized pipe into the inlet and use it to turn the gas valve (clockwise.) DO NOT OVER TIGHTEN or damage may result. NOTE: Use an approved TEFLON® tape or pipe compound only on the threaded section of the gas control valve/thermostat that screws into the tank.
2. Reconnect the gas piping to the gas control valve/thermostat. NOTE: Use an approved Teflon tape or pipe compound on the gas piping connections.
3. Attach the igniter and bracket to the new gas control valve/thermostat, clipping it at the back edge of thermostat and snapping it into place. NOTE: Do not use the (pilot) ferrule nut supplied with the new gas control valve/thermostat, unless the existing nut is not usable. Reconnect the pilot tube, manifold tube, igniter wire, and thermal switch wires. NOTE: L.P. gas systems use reverse (left-hand) threads on the manifold tube.
4. Fill the tank completely with water. NOTE: To purge the lines of any excess air, keep the hot water faucet open for 3 minutes after a constant flow of water is obtained.
5. Turn on the gas supply and test the gas supply connections by brushing on an approved noncorrosive leak detection solution. Bubbles forming indicate a leak. Correct any leak found.
6. Check the operation of the burner by following the lighting instructions on the front of the water heater. With the burner lit, check the gas control valve/thermostat supply line, manifold tube and pilot tube connections for leaks.
7. Verify proper operation and then replace the outer door.
8. If additional information is required, contact Residential Technical Assistance by referencing the phone number on the water heater.

TEFLON® is a registered trademark of E.I. Du Pont De Nemours and Company

ADJUSTING THE TEMPERATURE ON THE GAS CONTROL VALVE THERMOSTAT

⚠ DANGER

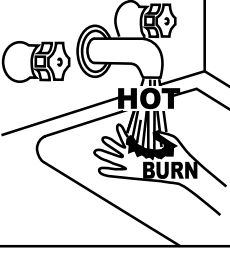

Water temperature over 125°F (52°C) can cause severe burns instantly resulting in severe injury or death.

Children, the elderly, and the physically or mentally disabled are at highest risk for scald injury.

Feel water before bathing or showering.

Temperature limiting valves are available.

Read instruction manual for safe temperature setting.

Due to the nature of the typical gas water heater, the water temperature in certain situations may vary up to 30°F (16.7 °C) higher or lower at the point of use such as, bathtubs, showers, sink, etc.

HOTTER WATER CAN SCALD: Water heaters are intended to produce hot water. Water heated to a temperature which will satisfy space heating, clothes washing, dish washing, and other sanitizing needs can scald and permanently injure you upon contact. Some people are more likely to be permanently injured by hot water than others. These include the elderly, children, the infirm, or physically/mentally handicapped. If anyone using hot water in your home fits into one of these groups or if there is a local code or state law requiring a certain temperature water at the hot water tap, then you must take special precautions. In addition to using the lowest possible temperature setting that satisfies your hot water needs, a means such as a mixing valve should be used at the hot water taps used by these people or at the water heater. Mixing valves are available at plumbing supply or hardware stores. Follow manufacturer's instructions for installation of the valves. Before changing the factory setting on the thermostat see following figure. Using the lowest hot water temperature that meets your needs will also provide the most energy efficient operation of the water heater.

Never allow small children to use a hot water tap, or to draw their own bath water. Never leave a child or handicapped person unattended in a bathtub or shower.

NOTE: A water temperature range of 120°F-140°F (49°C-60°C) is recommended by most dishwasher manufacturers.

The thermostat of this water heater has been factory set at its lowest position. It is adjustable and must be

reset to the desired temperature setting to reduce the risk of scald injury. The index bar (Robertshaw) and ▲ mark (White-Rodgers®) are indicative of approximately 120°F (49°C) and are the preferred starting points, see the figure below. Some states have a requirement for a lower setting.

White-Rodgers® Valves:

Turn the water temperature dial clockwise (↻) to decrease the temperature, or counterclockwise (↺) to increase the temperature.

Robertshaw® Valves:

Turn the water temperature dial clockwise (↻) to increase the temperature, or counterclockwise (↺) to decrease the temperature.

Should overheating occur or the gas supply fail to shut off, turn off the manual gas control valve to the appliance.

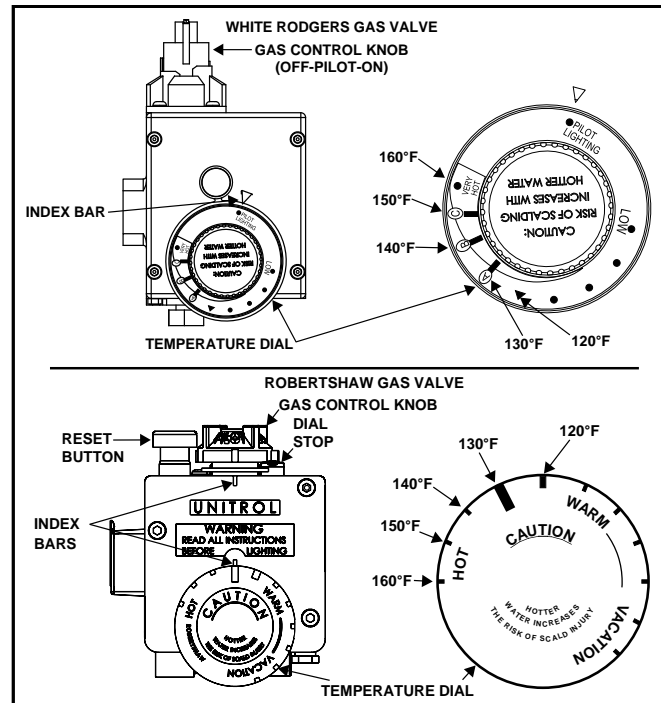

Water Temperature	Time to Produce 2nd & 3rd Degree Burns on Adult Skin
160°F (71°C)	About 1/2 second
150°F (66°C)	About 1-1/2 seconds
140°F (60°C)	Less than 5 seconds
130°F (54°C)	About 30 seconds
120°F (49°C)	More than 5 minutes
80°F (27°C)	-----

Figure 28

GAS WATER HEATER SIZING GUIDE

Use the following information as a guide to approximate the correct size water heater for the residence:

- 30 gallon size (21 gallon draw) for one bath residence.
- 40 gallon size (28 gallon draw) for two bath residence -or one bath with an automatic clothes washer.
- 50 gallon size (35 gallon draw) for three bath residence - or two baths with an automatic clothes washer.
- When a whirlpool tub is part of the home equipment, it is suggested that the water heater storage tank capacity be selected based on the needs of the whirlpool tub. This method of tank sizing, will in most cases, cancel all statements above concerning tank sizing.
- High flow or multiple shower head installations must be sized for at least a 20 minute draw.

Table 2:								
Tub Capacity to Overflow Outlet at:	80 gal.	90 gal.	100 gal.	110 gal.	120 gal.	130 gal.	140 gal.	150 gal.
(120°F Water) Min. Stored Water Capacity**	80 gal.	90 gal.	100 gal.	110 gal.	120 gal.	130 gal.	140 gal.	150 gal.
(140°F Water*) Min. Stored Water Capacity**	65 gal.	71 gal.	80 gal.	89 gal.	98 gal.	108 gal.	117 gal.	125 gal.
(@ 160°F Water*) Min. Stored Water Capacity**	54 gal.	59 gal.	66 gal.	74 gal.	82 gal.	90 gal.	97 gal.	104 gal.
*A thermostatic mixing valve set for a maximum temperature of 120° F is recommended to be installed to prevent a scalding hazard.								
**Based on tub water temperature of 105°								
Note: Because the desired fill time is normally 10 minutes, recovery capacity is not used for this calculation. All water used is supplied by storage.								
NOTE: The draw efficiency of a gas or electric water heater storage tank is considered to be 70%.								

LEAKAGE CHECKPOINTS

- A. Water at the draft hood is water vapor which has condensed out of the combustion products. This is caused by a problem in the vent.
 - B. *Condensation may be seen on pipes in humid weather or pipe connections may be leaking.
 - C. *The anode rod fitting may be leaking.
 - D. Small amounts of water from temperature-pressure relief valve may be due to thermal expansion or high water pressure in your area.
 - E. *The temperature-pressure relief valve may be leaking at the tank fitting.
 - F. Water from a drain valve may be due to the valve being slightly opened.
 - G. *The drain valve may be leaking at the tank fitting.
 - H. Combustion products contain water vapor which can condense on the cooler surfaces of the tank. Droplets form and drip onto the burner or run on the floor. This is common at the time of start-up after installation and when incoming water is cold.
 - I. Water in the water heater bottom or on the floor may be from condensation, loose connections, or the relief valve. DO NOT replace the water heater until a full inspection of all possible water sources is made and necessary corrective steps taken.
- * To check where threaded portion enters tank, insert cotton swab between jacket opening and fitting. If cotton is wet, follow draining instructions in the "Draining the Water Heater" section and then remove fitting. Put pipe dope or Teflon® tape on the threads and replace. When you are finished, follow the steps in "Filling the Water Heater" section.

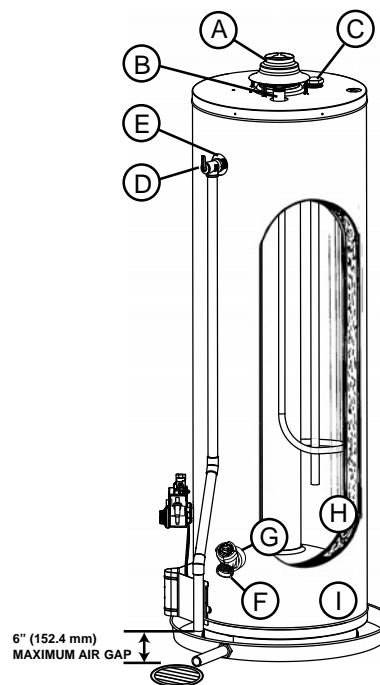

Figure 29

Leakage from other appliances, water lines, or ground seepage should also be checked.

TECHNICAL BULLETINS

WATER HAMMER	27
MINERAL BUILD-UP	28
ALUMINUM HYDROXIDE	29
CONDENSATION	30
DISCOLORED WATER.....	31
SMELLY WATER	32
CHLORINATION PROCEDURE	33
NOT ENOUGH HOT WATER	34
THERMAL EXPANSION.....	35-36
LEAKING TEMPERATURE AND PRESSURE RELIEF VALVE	37
INSULATION BLANKETS	38

BULLETIN 11

<h3>WATER HAMMER</h3>

GENERAL	<p>Water hammer is the destructive force, pounding noise and vibration in a piping system when water flowing through a pipeline is stopped abruptly. When water hammer occurs, a high intensity pressure wave travels back through the piping system until it reaches a point of some relief. The shock wave will then surge back and forth between the point of relief and the point of stoppage until the destructive energy is dissipated in the piping system. The violent action accounts for “banging”, “thumping”, and/or intense vibration in the pipe line. Although noise is generally associated with the occurrence of water hammer, it can occur without audible sound or noise. Quick closure of valves always causes some degree of shock with or without noise. The common cause of water hammer is single lever faucets (sinks/lavatories) or automatic solenoid valves dishwashers, washing machines, etc.). The speed of the valve closure time is directly related to the intensity of the surge pressure.</p>
EFFECTS	<p>The damage from water hammer can manifest itself in a number of ways. The most common are:</p> <ul style="list-style-type: none">• Expanded Tank Shell - This can be demonstrated by measuring the circumference at various locations along the shell. Pressures in excess of the maximum design working pressure can cause permanent deformation of the shell. NOTE: The continuous expansion of the tank shell may cause the tank to rupture at a welded seam.• Collapsed Flue Tube - This will choke off the ability to vent the products of combustion causing the flame and/or combustion to spill out from the combustion chamber. Often this will occur where thinning of the flue tube walls has occurred due to contamination of the combustion air or because of excessive condensation.• Inverted or Deformed Tank Heads - Often this accompanies collapsed flues, but one or both heads can be deformed.
THE FIX	<p>The only effective means of control is to install water hammer arrestors. These devices have diaphragms which separate an air chamber from the water in the piping system. As the shock wave reaches this device, the air chamber absorbs the shock. Arrestors should be located as close as possible to the source of the shock wave.</p>
NOTES	<p>Since water hammer exposes the equipment to pressures in excess of its design limits, failures caused by water hammer are not eligible for warranty consideration.</p>

BULLETIN 13

MINERAL BUILD-UP

SYMPTOMS	• Rumbling	• Crackling	• Popping
-----------------	------------	-------------	-----------

CAUSE	<p>With the increase in fuel costs and hot water consumption, deliming has become a necessity of modern maintenance. Lime (CaCO_3), is the most notable factor when discussing water hardness. Lime is present in every water system to some degree. Since lime is inversely soluble [the more you heat, the more lime comes out], higher usage, excessive hardness, and increased heating surface can lead to a high incidence of “limed-up” heaters.</p> <p>Symptoms often include a popping of water trapped under lime deposits or the sizzling of water trapped next to elements, boiling it to steam.</p>
--------------	---

THE FIX	<p>Treatment of a “limed-up” heater is relatively simple. Since CaCO_3 is a base, the easiest way to dissolve it so it can be flushed from the heater is with an acid. The most commonly used is phosphoric acid at a food-grade level.</p> <p>Two available treatments are Mag-Erad® and Un-Lime®. Any well stocked plumbing supply house should have a deliming solution available.</p> <p>The directions on the product should be followed explicitly.</p>
----------------	---

NOTES	<p>For additional information and instructions in deliming water heaters and boilers, please refer to the following pamphlets available from the Technical Information Center listed on the cover of this handbook:</p> <ul style="list-style-type: none">• Why? When & How: To Remove Water Scale from Tank Type Water Heaters• The Mag-Erad® Method of Cleaning Gas Fired Water Heaters• Up-N-Down Transfer Kit
--------------	---

BULLETIN 14

ALUMINUM HYDROXIDE

SYMPTOMS	“Crackling”, “gurgling”, or “popping” noises from new water heaters (installed less than six months).
-----------------	---

CAUSE	In a few isolated parts of the United States where the water supply has a relatively high pH (8+), water conditions will react with the aluminum anode to form excessive amounts of aluminum hydroxide on the anode and in the bottom of the tank. Aluminum hydroxide looks like “jelly beads” or a green, blue or gray gel like substance in the heater drain or at faucet aerators.
--------------	---

THE FIX	This procedure should only be performed by someone with abilities equal to a licensed tradesman. Aluminum hydroxide can be removed by using one of the methods outlined.
	If tank is new with <u>no</u> lime build-up to any degree:
	1 Turn off the heater.
	2 Remove the anode.
	3 Flush the tank thoroughly with water.
	4 Replace the aluminum anode (identifiable by smooth surface on plug) with magnesium anode (identifiable by weld bead on plug).
	If tank is new with lime build-up to any degree:
	1 Turn off the heater.
	2 Drain the heater.
	3 Remove the anode.
	4 Add UN-LIME to the tank. 20-40 gallon models (use 3 gallons of UN-LIME) 41-65 gallon models (use 5 gallons of UN-LIME) 66-100 gallon models (use 7 gallons of UN-LIME)
	5 Heat the UN-LIME to a temperature between 140°F to 160°F. • GAS - Heat for 7 to 10 minutes.
	6 Shut off the water heater.
	7 Allow the heated UN-LIME to stand for up to 12 minutes.
	8 Drain and flush the tank. Caution: UN-LIME will still be hot.
	9 Replace the original aluminum anode with a magnesium anode.
	10 Fill the system with water.
	11 Turn heater fuel “ON”.

NOTES	Since aluminum hydroxide is a product of a chemical reaction dependent on the water condition, any treatment is not considered warranty related.
--------------	--

BULLETIN 15

<h3>CONDENSATION</h3>

SYMPTOMS	The water heater appears to be releasing water while the main burner is on or water is found surrounding the heater shortly after the water heater has been used. This bulletin explains why flue gases condense and how you can differentiate between condensation and leaking.
CAUSES	<p>Condensate is the result of air borne water vapor being chilled below the dew point. The dew point is the temperature at which water vapor turns into liquid. Low incoming water temperatures cool the piping and the heat transfer surfaces of the water heater. When the main burner comes on, the hot flue gases turn into condensate upon contact with these surfaces. The typical home water heater will produce about one-half gallon of water vapor during every hour of operation. Condensate is often mistaken for leaking.</p> <p>Newer heaters will condensate more than older heaters because modern water heaters are much more efficient than their predecessors. The newer heaters utilize as much of the energy out of the main burner flame as possible. This lowers the flue gas and tank storage temperature and closer to the dew point temperature.</p>
DIAGNOSIS	<p>To distinguish between a condensating water heater and a leaking water heater:</p> <ol style="list-style-type: none">1. Wipe up any water under the heater.2. Turn the knob on the thermostat to the pilot position.3. Wait 8 hours, check for water accumulation under the heater.4. Condensation should stop when the entire tank water is heated above approximately 115 degrees.<ul style="list-style-type: none">• If no water is under the heater, the water heater was condensating.• If water is under the heater, check further for a loose fitting. If all fittings are tight and the tank is leaking, replace the water heater. Leaking heaters cannot be "repaired".

BULLETIN 21

DISCOLORED WATER

SYMPTOMS	Rusty, brown, black, or yellow water appearing in the hot water.
-----------------	--

CAUSES	<p>Complaints of discolored water are commonly blamed on water heaters and storage tanks, but in fact, it is a rare occurrence for today's high quality glass lined tanks to have a lining failure significant enough to allow water to contact enough bare metal to discolor the contents of even a small tank.</p> <p>The most common cause of "rusty" water is a non-toxic iron reducing bacteria, scientifically termed Crenothrix, Leptothrix, and Gallionella. Iron bacteria is commonly found in soil, water wells, water treatment plants and water distribution piping systems where soluble iron exceeds 0.2 ppm, higher levels make conditions even more favorable. Soluble iron in the water provides food for the bacteria. Rusty discolored water is the end result of the bacteria feeding process. Water heaters and storage tanks usually require new anode rods as presence of iron bacteria contributes to premature anode failure.</p> <p>The requirements for the bacteria to thrive are:</p> <ul style="list-style-type: none">• Elevated levels of iron and manganese in the water• Water with little or no dissolved oxygen• Temperatures below 138°F <p>Items that can increase the potential for this bacteria are:</p> <ul style="list-style-type: none">• Water softeners• Well water• Long periods of no water movement
---------------	--

TREATMENT	The simplest treatment available is shock-chlorination of the system. This is a surface treatment, and often requires repeated trials in heavily infected systems. The chlorination of a system requires that you follow each step explicitly to avoid an untreated portion of the piping system from reinfesting another part. See Bulletin 23 for the chlorination procedure.
------------------	---

NOTES	Since rusty water is caused by a bacteria presence and is not caused by the water heater, any treatment would not be considered warranty related.
--------------	---

BULLETIN 22

SMELLY WATER

CAUSES	<p>The most common cause of “smelly water” is a non-toxic sulfate reducing bacteria, scientifically termed <i>Divibrio Sulfurcans</i>. This bacteria often enters the water system through construction or a break in ground piping. The bacteria creates the energy it needs to survive by converting sulfate (SO₄) to hydrogen sulfide(H₂S) gas you smell in the water.</p> <p>Hydrogen sulfide gas is distinctive because of its rotten egg-like stench. Its presence can severely affect the taste as well as the odor of the water. Occasionally this bacteria can be accompanied by black deposits, the result of pipe and fitting corrosion. In extremely high concentrations, hydrogen sulfide gas can be toxic though the gas is detectable long before harmful levels are reached.</p> <p>The requirements for the bacteria to thrive are: a) an elevated level of sulfur in the water, b) activated hydrogen from cathodic reactions within the tank, c) water with little or no dissolved oxygen, d) and temperatures below 138°F.</p> <p>Items that can increase the potential for this bacteria are: a) water softeners, b) well water, c) and long periods of no water movement.</p> <p>Other factors that may contribute to smelly water:</p> <ul style="list-style-type: none">• Chlorides of Magnesium and Calcium leave a bitter taste.• Chloride of Sodium produces a salty taste.• Sulfates (50 ppm) gives a medicinal taste.• Carbon Dioxide in a low pH water gives fizzy water.• Iron and tannic waters also give a bad taste and odor.
TREATMENT	<p>The simplest treatment available is the shock-chlorination of the system. This is a surface treatment, and often requires repeated trials in heavily infected systems. The chlorination of a system requires that you follow each step explicitly to avoid an un-treated portion of the piping system from re-infecting another part. See Bulletin 23 for the chlorination procedure. Longer lasting solutions include chlorination or aeration of the water supply.</p>
NOTES	<p>Since rusty water is caused by a bacteria presence and is not caused by the water heater, any treatment would not be considered warranty related.</p>

BULLETIN 23

CHLORINATION PROCEDURE

CAUSES	The chlorination procedure is used to eliminate various bacteria that accumulate and grow in water heaters. These bacteria often cause odorous or discolored water conditions.
---------------	--

PROCEDURE	Please read the steps of the chlorination procedure prior to beginning. If you feel uncomfortable performing any of these steps, contact a service person to perform this procedure for you.
STEP 1	Turn off the gas or electric supply to the tank.
STEP 2	Turn off the cold water supply valve to the tank.
STEP 3	Open a nearby hot water faucet to relieve the vacuum.
STEP 4	Drain all the water from the tank (a water-hose may be needed).
STEP 5	Remove the anode rod(s), and close the drain valve.
STEP 6	Using a funnel in the anode opening add one gallon of household chlorine bleach for every 25 gallons of tank capacity.
STEP 7	Reinstall anode rod(s) after inspecting and replacing as needed.
STEP 8	Open cold water supply valve and refill the system. Then draw the water to every hot water fixture, until the smell of chlorine is detected. Operate dish and clothes washers until a noticeable amount of the chlorine is detected as well. All hot water lines must receive treatment.
STEP 9	Leave the chlorine solution undisturbed for one hour or more.
STEP 10	After the contact time has elapsed, drain the tank according to steps #2, #3, & #4.
STEP 11	Close the drain valve and refill the tank. Allow the tank to sit for 15 minutes. Repeat steps #2, #3, and #4. Continue to flush the tank if the water is discolored or contains a chlorine odor.
STEP 12	Close the drain valve and refill the tank. Flush all chlorine from the piping by opening every hot water outlet/ appliance.
STEP 13	Return hot water heating system to service by following the recommended start-up procedure posted on the unit or in the manual.

BULLETIN 35

NOT ENOUGH HOT WATER - GAS

CAUSES	Complaints regarding an insufficient supply of hot water are typically the result of a water heater that cannot meet the demands of the residence (both people and appliances). The demand for sufficient hot water may also be exceeded if additional people and/or appliances are added to the residence. Another factor that may reduce the hot water output is mineral build-up. Reference Bulletin 13 to determine if mineral build-up may be effecting your hot water output. The following test will help determine if a water heater is supplying the intended amount of hot water.
---------------	---

TEST	Please read all the steps of the test prior to beginning. NOTE: This test is based on 140° F storage temperature and these amounts are approximate.																																																																																										
STEP 1	<p>Do not use any hot water for two hours to ensure the accuracy of this test. Turn on the cold water at full flow using a double handle faucet and time how long it takes to fill a one-gallon jug. Calculate the Gallons Per Minute (GPM) flow rate as follows.</p> <p>One-gallon Jug filled in:</p> <p style="margin-left: 40px;">5 seconds = 12 gallons per minute 10 seconds = 6 gallons per minute 15 seconds = 4 gallons per minute 20 seconds = 3 gallons per minute 30 seconds = 2 gallons per minute</p>																																																																																										
STEP 2	<p>Using a thermometer, turn on the hot water and time how long it takes for the water temperature to drop 30 degrees.</p> <table border="1" style="margin-left: auto; margin-right: auto; border-collapse: collapse; text-align: center;"> <thead> <tr style="background-color: #cccccc;"> <th colspan="9">Gallons Per Minute (GPM) Flow Rate</th> </tr> <tr style="background-color: #cccccc;"> <th></th> <th>1.5</th> <th>2</th> <th>2.5</th> <th>3</th> <th>3.5</th> <th>4</th> <th>5</th> <th>6</th> </tr> </thead> <tbody> <tr> <td style="text-align: left;">30 Gallon Tank</td> <td>14 min.</td> <td>10 min.</td> <td>8 min.</td> <td>7 min.</td> <td>6 min.</td> <td>5 min.</td> <td>4 min.</td> <td>3 min.</td> </tr> <tr> <td style="text-align: left;">40 Gallon Tank</td> <td>18 min.</td> <td>14 min.</td> <td>11 min.</td> <td>9 min.</td> <td>8 min.</td> <td>7 min.</td> <td>5 min.</td> <td>4 min.</td> </tr> <tr> <td style="text-align: left;">50 Gallon Tank</td> <td>23 min.</td> <td>17 min.</td> <td>14 min.</td> <td>12 min.</td> <td>10 min.</td> <td>9 min.</td> <td>8 min.</td> <td>6 min.</td> </tr> <tr> <td style="text-align: left;">65 Gallon Tank</td> <td>30 min.</td> <td>22 min.</td> <td>18 min.</td> <td>15 min.</td> <td>13 min.</td> <td>11 min.</td> <td>9 min.</td> <td>8 min.</td> </tr> <tr> <td style="text-align: left;">75 Gallon Tank</td> <td>35 min.</td> <td>26 min.</td> <td>21 min.</td> <td>17 min.</td> <td>15 min.</td> <td>13 min.</td> <td>10 min.</td> <td>8 min.</td> </tr> <tr> <td style="text-align: left;">100 Gallon Tank</td> <td>47 min.</td> <td>35 min.</td> <td>28 min.</td> <td>23 min.</td> <td>20 min.</td> <td>17 min.</td> <td>14 min.</td> <td>11 min.</td> </tr> <tr> <td style="text-align: left;">119 Gallon Tank</td> <td>56 min.</td> <td>42 min.</td> <td>33 min.</td> <td>28 min.</td> <td>24 min.</td> <td>21 min.</td> <td>17 min.</td> <td>14 min.</td> </tr> <tr style="background-color: #cccccc;"> <th colspan="9">Minutes to drop 30° F</th> </tr> </tbody> </table> <p>Example: 10 seconds to fill the one-gallon jug equals 6 gallons per minute flow rate. If the temperature drops 30 degrees in 6 minutes that equals 36 gallons of hot water. This is normal for a 50 gallon water heater. The amount will be about 70% of the capacity of the heater.</p>	Gallons Per Minute (GPM) Flow Rate										1.5	2	2.5	3	3.5	4	5	6	30 Gallon Tank	14 min.	10 min.	8 min.	7 min.	6 min.	5 min.	4 min.	3 min.	40 Gallon Tank	18 min.	14 min.	11 min.	9 min.	8 min.	7 min.	5 min.	4 min.	50 Gallon Tank	23 min.	17 min.	14 min.	12 min.	10 min.	9 min.	8 min.	6 min.	65 Gallon Tank	30 min.	22 min.	18 min.	15 min.	13 min.	11 min.	9 min.	8 min.	75 Gallon Tank	35 min.	26 min.	21 min.	17 min.	15 min.	13 min.	10 min.	8 min.	100 Gallon Tank	47 min.	35 min.	28 min.	23 min.	20 min.	17 min.	14 min.	11 min.	119 Gallon Tank	56 min.	42 min.	33 min.	28 min.	24 min.	21 min.	17 min.	14 min.	Minutes to drop 30° F								
Gallons Per Minute (GPM) Flow Rate																																																																																											
	1.5	2	2.5	3	3.5	4	5	6																																																																																			
30 Gallon Tank	14 min.	10 min.	8 min.	7 min.	6 min.	5 min.	4 min.	3 min.																																																																																			
40 Gallon Tank	18 min.	14 min.	11 min.	9 min.	8 min.	7 min.	5 min.	4 min.																																																																																			
50 Gallon Tank	23 min.	17 min.	14 min.	12 min.	10 min.	9 min.	8 min.	6 min.																																																																																			
65 Gallon Tank	30 min.	22 min.	18 min.	15 min.	13 min.	11 min.	9 min.	8 min.																																																																																			
75 Gallon Tank	35 min.	26 min.	21 min.	17 min.	15 min.	13 min.	10 min.	8 min.																																																																																			
100 Gallon Tank	47 min.	35 min.	28 min.	23 min.	20 min.	17 min.	14 min.	11 min.																																																																																			
119 Gallon Tank	56 min.	42 min.	33 min.	28 min.	24 min.	21 min.	17 min.	14 min.																																																																																			
Minutes to drop 30° F																																																																																											

RESULTS	If the test performed above results in a 70% (+/- 10 %) capacity, then the heater is performing per specifications and a larger water heater should be considered in order to meet the demand.
----------------	--

BULLETIN 45

<h3>THERMAL EXPANSION</h3>

SYMPTOMS	<ul style="list-style-type: none">• Effects are only noticeable after hot water use followed by periods of no water use.• Relief valve drips during any recovery cycle when no hot or cold water is used.• Hot water pipes creak while heater is recovering and all valves are closed.• Tanks or other components of the water supply system fail prematurely.• A metallic creaking noise might actually be heard in the location of the heater as the pressure is relieved and the stretched tank returns to a natural shape.• Faucet drips during any recovery cycle when no hot or cold water is used.• Water surges when a faucet is first opened and then pressure drops.
-----------------	--

CAUSE	<p>The water in a water heating system expands when it is heated and increases in volume. Since water will not compress (like air), system designers must include provisions for thermal expansion. (Water in a closed tank at 50 psi, when heated just 10 degrees, will reach a pressure of 250 psi).</p> <p>Many water supply systems have check valves or backflow preventers at the water meter to prevent any possible contamination of the public water supply by the accidental back-flow of contaminated water into the supply mains. These check valves are often required by code, and some cities are even installing the check valves. They serve a useful purpose. Do not remove them!</p> <p>The use of pressure reducing valves (PRV) is another cause. PRVs are designed to conserve water and prolong fixture life. Many PRVs also act as very effective check valves. Again, do not remove them!</p> <p>Water softeners in the system may also act as back-flow preventers.</p>
--------------	---

TEST	<p>Follow these easy steps to diagnose thermal expansion:</p> <ul style="list-style-type: none">• Turn the heater thermostat all the way down, and install a water pressure gauge with dead hand on the drain valve. Open the drain valve, so the gauge reads system pressure.• Open a hot water tap and allow 15% to 20% of the tanks volume to run out. Shut off the drain valve and make sure that no other fixture in the system, hot or cold, is open. Make sure that outside fixtures, if they are on the same system, are turned off too. Any water leaks or use will make the test meaningless.• Check the water pressure gauge, and turn the pointer so it lines up with the pressure indicating needle. Turn the thermostat back up to its normal position, so the heater cycles on. Watch the pressure gauge.• If the system is closed, the pressure will start to climb steadily and rapidly. A small amount of thermal expansion control may be built into the system because of trapped air pockets or a water hammer arrestor. In that case the pressure will increase slightly, hold steady for a short time and then rapidly increase. The temperature and pressure relief valve (T&P) or PRV should open and release water once the pressure reaches the maximum setting on the valve. The valve will close once the pressure falls below the pressure setting of the valve.
-------------	---

THERMAL EXPANSION

THE FIX

The ideal fix involves the use of a pressure reducing valve if supply pressures are above 60 to 70 psi, and a properly sized expansion tank. The PRV reduces supply pressures to 40 to 60 psi allowing an economically priced and sized expansion tank to be used. The PRV also offers the benefit of saving water and prolonging the life of water flow valves. The PRV is not required if the system already has one or if high supply pressures are desired. A supply water pressure of 80 PSI is a maximum set by many local or state codes.

The PRV is installed between the check valve and the water heating system. The expansion tank is installed between the PRV and the water heating system. Follow the manufacturers instructions for installing the expansion tank.

Run the thermal expansion check again. The pressure should increase only slightly then hold steady throughout the recovery cycle. The expanded water is flowing back from the heater and into the pressurized storage bladder of the expansion tank. Air pressure will force this water out of the expansion tank into the supply once usage resumes.

DO NOT DEPEND ON THE TEMPERATURE & PRESSURE VALVE (T&P VALVE) TO HANDLE THERMAL EXPANSION! The T&P valve manufacturers designed the valve to be an emergency relief device only. The T&P Valve could be subject to reduced effectiveness or failure.

FIGURE

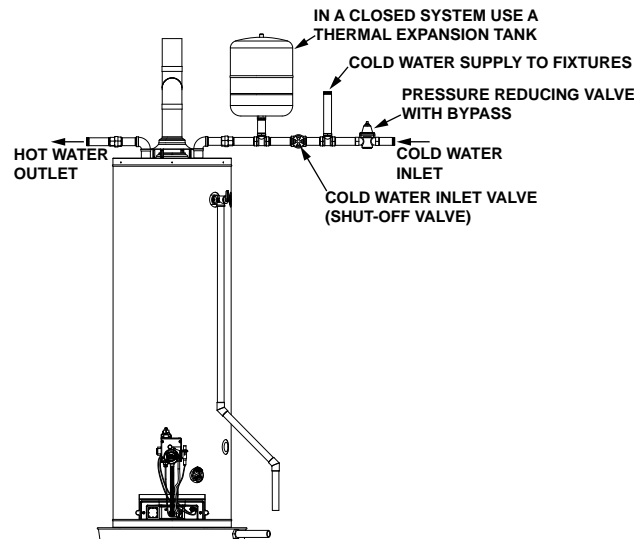

WARNING

Thermal expansion of water, if not compensated for in system design, will lead to the early failure of components. These failures are not covered by the manufacturer's warranty, so it is extremely important that everyone be aware of the causes, symptoms and solutions to thermal expansion in a closed water heating system.

BULLETIN 52

<h3>LEAKING TEMPERATURE AND PRESSURE RELIEF VALVE</h3>
--

SYMPTOMS	<ul style="list-style-type: none">• Water seeping around the relief valve tank connection• Leakage at the threaded portion of the relief valve connection• Intermittent weeping and/or dribbling from the relief valve• Large volume of hot water sporadically discharged from the relief valve
-----------------	--

GENERAL	<p>The temperature and pressure relief valve (T & P) is a safety device limiting temperature and pressure levels in a water heater. Each T & P has both a temperature and pressure rating.</p> <p>Normally, the temperature and pressure relief valve will have a temperature rating of 210°F. A probe (part of the relief valve) extends into the tank measuring the stored water temperature. This probe must be within the top six inches of the water heater. If the water heater's thermostat malfunctions, higher than normal water temperatures could be produced. Once the probe senses a temperature approaching its temperature rating, the relief valve will open to full capacity releasing "very hot" water until the temperature is below its reset temperature.</p> <p>The pressure rating on the relief valve should be the same or less than the certified working pressure of the tank (generally 150 psi) and be below the lowest maximum working pressure rating of any system components. Once the pressure in the tank reaches the valve's pressure rating, it will slightly open relieving the pressure. Relieving of pressure can be noted as "dribbling" or "weeping" water from the relief valve.</p> <p>If an incorrectly sized temperature and pressure relief valve is installed, the warranty will be void.</p>
----------------	---

THE FIX	<p>Follow these easy steps to diagnose thermal expansion:</p> <ul style="list-style-type: none">• Intermittent weeping and/or dribbling at the relief valve - The relief valve relieves water slowly when actuating on pressure. A closed system can cause pressure to increase in the system. This condition is called thermal expansion. For additional information regarding thermal expansion please see Bulletin 45.• Leaking at the spud of the water heater - Spuds are welded to the tank and are not repairable. The heater should be replaced.• Leakage at the threaded relief valve connection - Remove relief valve and reseal connection.• Large volume of hot water sporadically discharged from the relief valve - The relief valve relieves water quickly when actuating on temperature. The only cause of this problem is a malfunctioning thermostat.
----------------	--

BULLETIN 60

INSULATION BLANKETS	
----------------------------	--

GENERAL	<p>The purpose of an insulation blanket is to reduce the standby heat loss encountered with storage tank heaters.</p> <p>Most modern water heaters have adequate factory installed insulation, the use of an after market insulation blanket is no longer recommended by most experts. While the use of an external insulation blanket will not void the warranty, the water heater manufacturer explicitly disclaims any liability for problems associated with the use of insulation blankets.</p> <p>NOTE: A few local energy codes may still require the use of insulation blankets on water heaters. Be sure to follow all installation instructions, cautions, and warnings for the insulation blanket as well as the cautions and warning of the water heaters owners manual.</p>
----------------	--

NOTES	<p>Should you choose to apply an insulation blanket to this heater, you should follow these instructions. Failure to follow these instructions can restrict the air flow required for proper combustion, resulting in fire, asphyxiation, serious personal injury or death.</p> <ul style="list-style-type: none">• Do not cover the outer door, thermostat or temperature & pressure relief valve.• When installed the insulation blanket will cover important safety and operation labels. Obtain new warning and instruction labels from the Technical Information Center listed in the owners manual. The replacement labels must be placed on the blanket in the location of the original labels on the water heater jacket.• Do not cover the instruction manual. Keep it on the side of the water heater or nearby for future reference.• Do not apply insulation to the top of the water heater, as this will interfere with safe operation of the draft hood.• Do not allow insulation to come within 2" of the base of the water heater to prevent blockage of combustion air flow to the burner. The combustion air openings in the base of the water heater must NOT be obstructed.• Inspect the insulation blanket frequently to make certain it does not sag, thereby obstructing combustion air flow.
--------------	---

GENERAL INFORMATION

Draw efficiency is the quantity of hot water available to the consumer before the outlet water temperature decreases 25 degrees F. A 40 gallon water heater will typically provide 70% (28 gallons) of this “usable” hot water (60% is the minimum). The burner or elements are allowed to operate during this test. Incoming, cold water mixes the remaining stored water below this 25 degree limitation.

Energy Factor is an indicator of the combined thermal efficiency and standby efficiency of a water heater. The higher the energy factor, the more efficient the water heater will be.

Minerals and gases will separate from water as temperature increases.

“R” Value is a measure of the resistance of a substance to heat flow.

Recovery rate is the amount of water that is heated to a set temperature, per hour. An example might be that a water heater has a recovery rate of 30 gallons of water per hour at 80 degree F. (Fahrenheit) temperature rise.

Standby efficiency – the water heater’s ability to contain heat in the tank. A minimum of tank water heat loss per hour is desired.

$$\text{Sample: } \frac{\text{temperature change}}{\text{“R” value}} = \text{Btu/h loss/ square foot of tank surface}$$

Temperature rise is the increase in the temperature from its coldest “inlet” water temperature to the desired hot (outlet) setting. Typically this is assumed to be 40 degrees entering water, 120 degrees desired stored water or 80 degrees “temperature rise.”

Thermal efficiency is approximately the amount of generated BTU (British Thermal Units), which enters the water. A percentage of the total BTU passes out through the vent piping.

Water cannot (for all practical purposes) be compressed.

Water expands when it is heated.

Formulas and Conversions:

BTU (British Thermal Unit) is the heat required to raise 1 pound of water 1°F

$$1 \text{ BTU} = 252 \text{ cal} = 0.252 \text{ kcal}$$

$$1 \text{ cal} = 4.187 \text{ Joules}$$

$$\text{BTU} \times 1.055 = \text{Kilo Joules}$$

$$\text{BTU divided by } 3,413 = \text{Kilowatts}$$

To convert from Fahrenheit to Centigrade: ($^{\circ}\text{F} - 32$) times $5/9$, or $.556$, equals degrees C.

One gallon of (120°F , 49°C) water weighs approximately 8.25 pounds.

$$\text{Pounds} \times .45359 = \text{Kilogram}$$

$$\text{Gallons} \times 3.7854 = \text{Liters}$$

$$\% \text{ of Hot} = (\text{Mixed Temp.} - \text{Cold}) \text{ divided by } (\text{Hot Temp.} - \text{Cold})$$

$$\% \text{ Thermal Efficiency} = (\text{GPH} \times 8.25 \times \text{Temp. Rise} \times 1.0) \text{ divided by BTU/H Input}$$

$$\text{BTU Output} = \text{GPH} \times 8.25 \times \text{Temp. Rise} \times 1.0$$

$$\text{GPH} = (\text{BTU/H Input} \times \% \text{ Eff.}) \text{ divided by } (\text{Temp. Rise} \times 8.25)$$

One cubic foot of Natural Gas contains about 1000 BTU of heat.

One “therm” is equal to 100,000 BTU

One cubic foot of Propane Gas contains about 2500 BTU of heat.

One gallon of Propane gas contains about 91,250 BTU of heat.

One pound of Propane gas contains about 21,600 BTU of heat.

GENERAL INFORMATION

One pound of **gas pressure** is equal to 27.7 inches water column pressure

Inches of Water Column X .036091 = PSI

Inches of Water Column X .073483 = Inches of Mercury (Hg.)

Centimeters = Inches X 2.54

MM (millimeters) =Inches X 25.4

Meters = Inches X .0254

Doubling the diameter of a pipe will increase its flow capacity (approximately) 5.3 times.

Construction: **Tank** is constructed of steel.

The inside of the tank is constructed of a glass lining bonded to the steel. This prevents water to metal contact and rusting of the tank.

An **anode rod** will be installed within the tank. The hex-head plug end of the anode is visible on the top of the water heater. This metal rod offers secondary protection of the tank against corrosion where the application of glass is not possible (threaded tank openings). These areas will have small areas of water to metal contact.

All water heaters will contain at least **one thermostat** (to operate the heater) and **one high limit** (to prevent water temperatures approaching the "steam" level).