

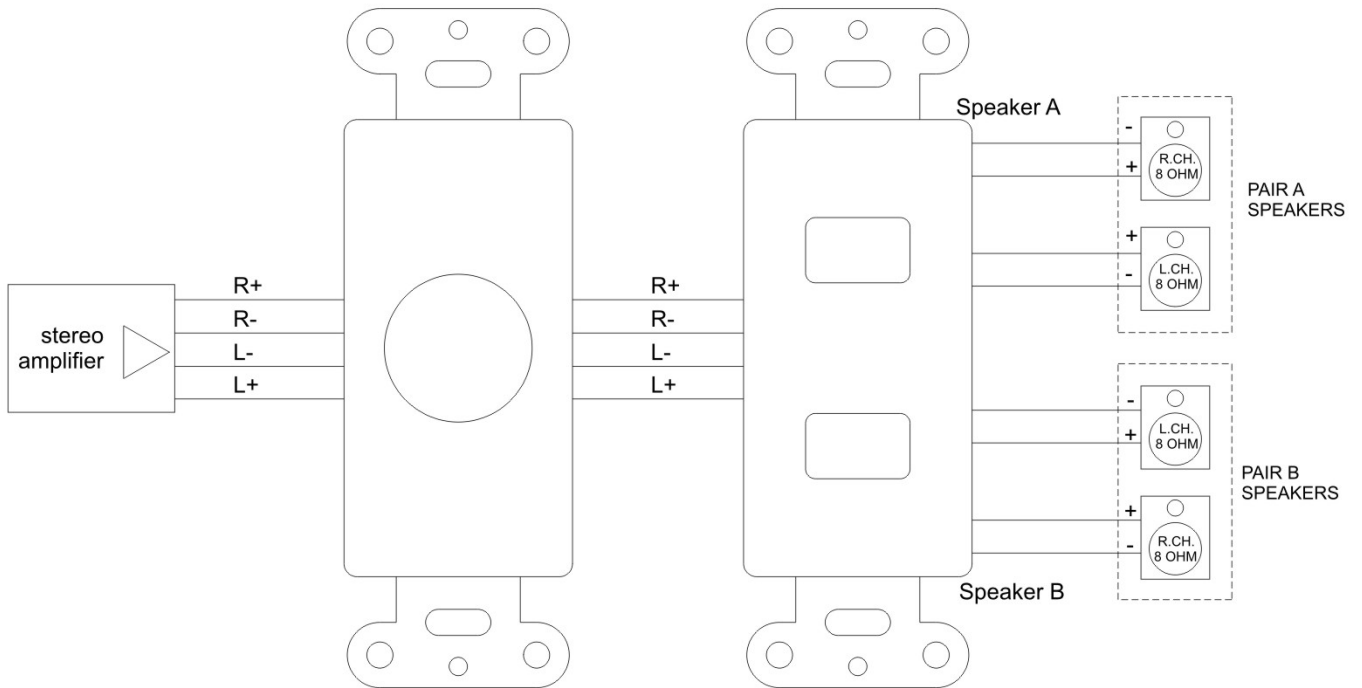

In-Wall A/B Speaker Switch

1. With volume control



2. Without volume control

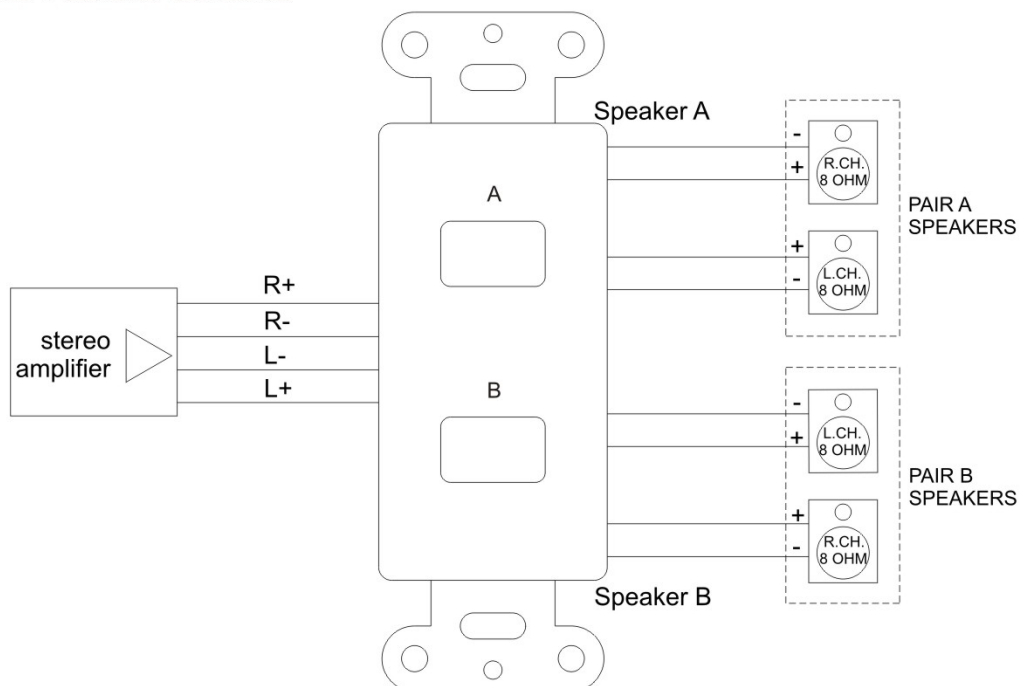

- Volume control should be auto transformer type control.
- The use of 8 ohm speakers is recommended. When A and B all selected, the net load to amplifier is 4