

Backset

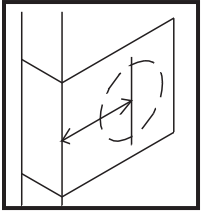

Backset is the distance from the door edge to the center of the hole on the door face. Master Lock door locks are supplied with an adjustable latch which can fit 2-3/8" (60mm) or 2-3/4" (70mm) backset.

L

Follow steps below to change backset.

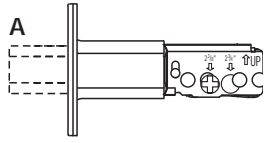

a. Rotate latch crank to retract the latchbolt to the unlock position.

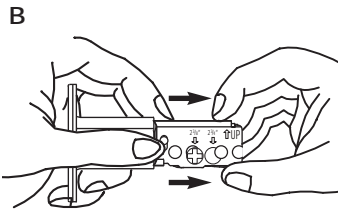

b. Push the change lever up against the top. Hold torque plate and torque spring then pull the extension plate all the way out. Be sure the 2-3/4" (70mm) screw hole is properly aligned and "change lever" jumps down to original position.

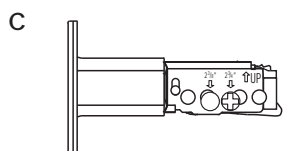

c. Your latch is now set for 2-3/4" (70mm) backset.

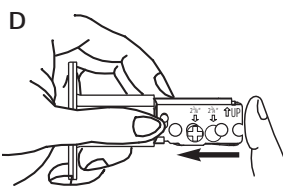

d. Latch may be adjusted back to 2-3/8" (60mm) backset by retracting the latchbolt, pushing up the "change lever" and moving the extension plate back to its original position.

(NOTE: Be sure the 2-3/8" (60mm) screw hole is properly aligned and "change lever" jumps down to original position after alignment.)

Attach the faceplate that matches the mortise in the edge of your door

To change faceplates:

1. Use a flat screwdriver to separate the faceplate.
2. Snap selected faceplate onto backplate.

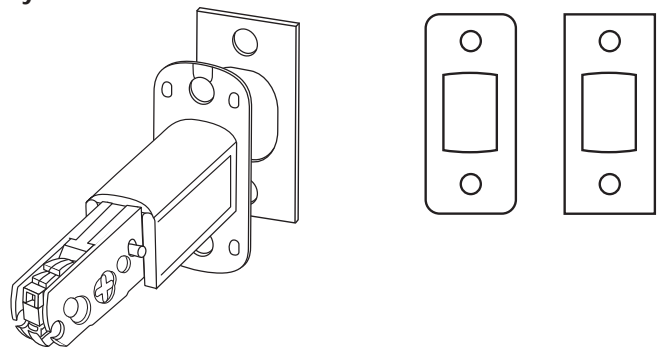

Mark door with template

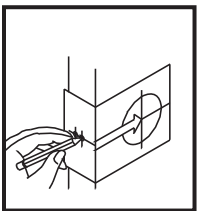

Select 2-3/8" or 2-3/4" (60mm or 70mm) backset as desired and mark center of hole on door face.

Drill holes

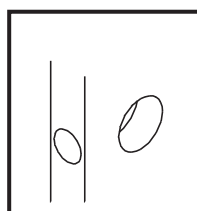

Drill 2-1/8" (54mm) hole on door face from both sides to avoid wood splitting. Drill 1" (25.4mm) hole for latch.

Install latch

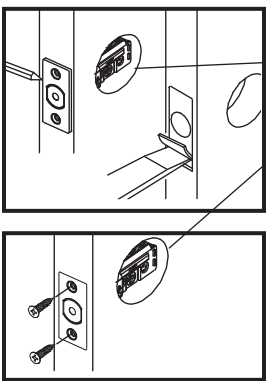

Insert latch in hole, mark outline of face plate and chisel 1/64" (4mm) deep.

Insert latch and tighten screws.

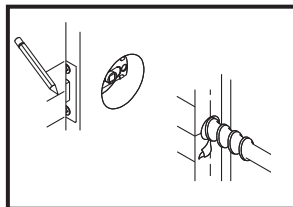

Close door to mark horizontal centerline of strike.

Measure one half of door thickness from doorstop and mark for the vertical centerline of strike. Drill 1" hole, 1/2" deep at the intersection of the horizontal and vertical centerlines.

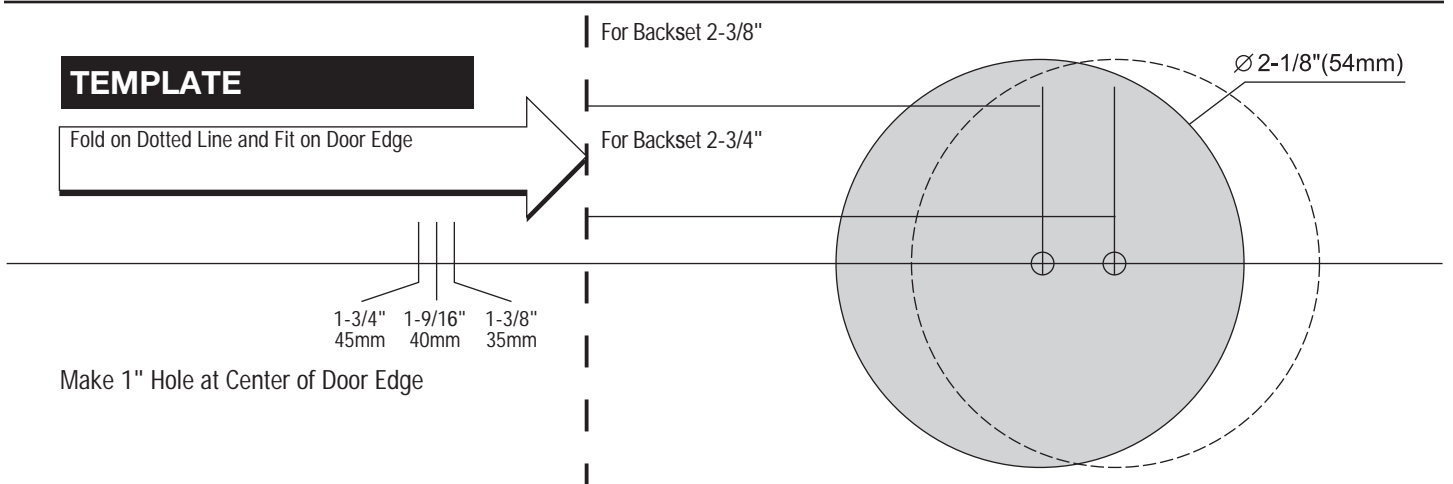

Install strike

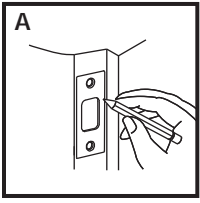

- Match screw holes on strike with vertical centerlines on jamb. Mark outline of strike plate and chisel out until strike is flush with jamb. (Approx. 1/8")
- Install strike and tighten screws.

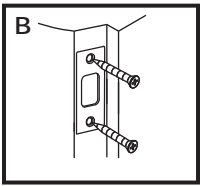

Install exterior mechanism – single cylinder

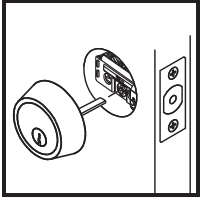

Press cylinder side flush against door making certain the torque blade is properly positioned in latch crank. Tapped holes in housing of exterior cylinder should be lined up with screwholes. Key hole should be in down position. TORQUE BLADE SHOULD HORIZONTALLY INSERTED INTO LATCH CRANK.

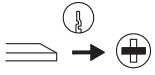

Install interior mechanism – single cylinder

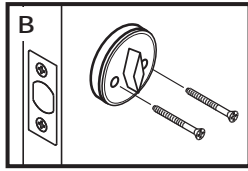
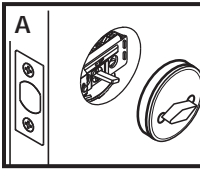

- Slide turnpiece and interior rosette onto torque blade.
- Insert machine screws through holes engaging holes in cylinder and tighten firmly.

Install exterior cylinder – double cylinder

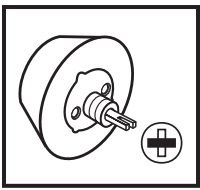

Press exterior cylinder flush against door. Exterior torque blade should be horizontally inserted into latch crank first.

Install interior cylinder – double cylinder

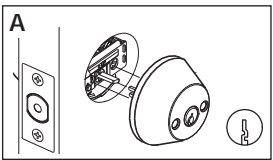

- Press interior assembly flush against door, making certain the torque blade is properly positioned in latch crank. Keyhole should be in down position.
- The interior torque blade is inserted into the exterior hole.
- Insert two screws through countersunk holes engaging holes in exterior cylinder and tighten firmly.

