



Super Slide II PowerSlide Installation Guide

Quantity Description

Quantity	Description
1	Power module
1	Power module drive channel
4	Limit switches
8	Slide switch spacers
8	Screw BHCS 4-40 x 1"
8	Nut Nylock 4-40
2	5/16"-18 x 1 HH GR.5 bolts
2	5/16-18 Nylock nuts
4	1/4"-20 x 3/4 HH GR.5 bolts
4	1/4 Split lock washers

CAUTION
Caution should be used when tightening the screws retaining the limit switches to prevent over tightening and fracture of the switch case.



Introduction

The **SuperSlide II Powerslide Assembly Instructions** are for adding the **power slide module** to an already installed manual slide or an unassembled version of the power slide.

For a fully assembled version, skip to the section titled **Assembly into Coach** beginning on Page 3.

For an unassembled version, begin by following the instructions provided in the kit for the manual slide, which are included in the rail slider kit. Once the manual slide is assembled, use the **SuperSlide II Powerslide Assembly Instructions** to install the power drive option. The power drive option comes fully assembled and requires only the addition of wiring.

Operating Safety Precautions

Begin SuperSlide II PowerSlide assembly by connecting the limit switches to the manual tray. See **Figure 1** for limit switch locations. A total of 4 switches will be placed on the tray.

The switches should be connected to the fixed rail that is on the **front** side of the coach. When the power module is finished, it will be located on the front side of the coach.

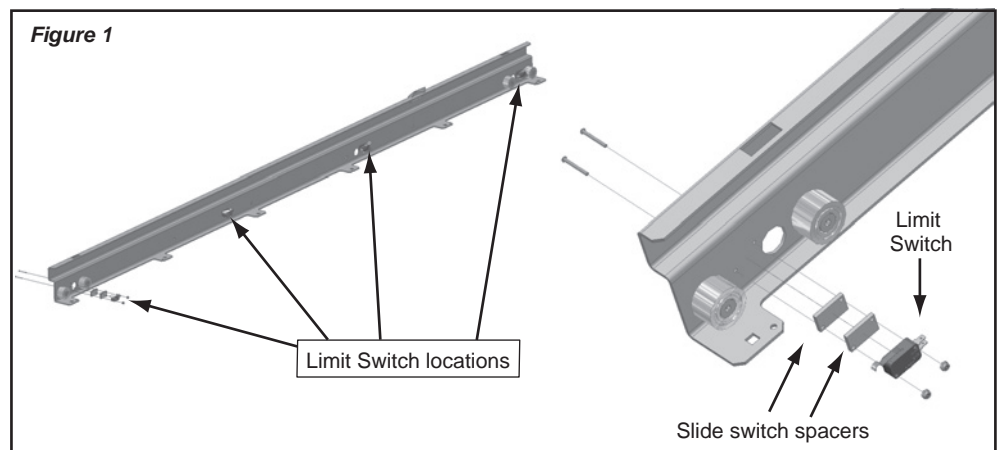

Extending Your Cargo Tray



CAUTION

See operating safety precautions before proceeding.

- To extend the tray from the stowed center position, use one of the following two options.
 - Push and hold the rocker switch provided by the coach manufacturer in the desired direction.
 - Momentarily press the arrow on the remote control in the desired direction.
- The tray will continue to travel to the full extension point or until either the rocker is released or any button on the remote control is pressed again.
- To extend the tray from one side to the other, the tray will need to be stowed first by either pressing "Stow" or the direction of travel arrow on the remote control. If the rocker switch is used, after the tray is centered, the rocker must be released before the tray can be further extended.

Note: To stop the tray, release the rocker switch or momentarily press any button on the remote control panel.



Stowing Your Cargo Tray



CAUTION

See operating safety precautions before proceeding.

- To stow the cargo tray, press the stow button on the remote control or the arrow in the desired direction required to stow the tray. The slide will stow automatically.
- If using the rocker switch to retract the cargo tray, press and hold the switch. The cargo tray will momentarily pause just before centering. Continue to hold the rocker switch down until all action stops.

Programming Your Remote

To program the power module to the RF remote transmitter, insert the eraser end of a pencil through the hole in the top of the ABS cover on the power slide, as shown in figure 1. The hole is located on the passenger top side of cover.

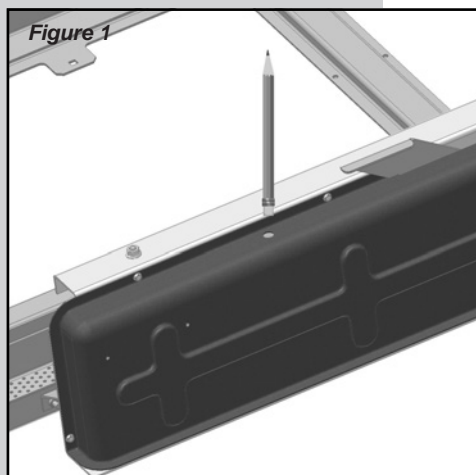

With the eraser end of the pencil, press the switch on the top of the control. When pressed, a red LED light will start to flash. The LED can be seen through the hole in the cover. Once flashing, select which set of buttons you would like to have correspond to this slide. Press any button on the remote that corresponds to Slide 1 or Slide 2. this will program the slide to that remote setting.

Troubleshooting

1. Unit fails to extend or retract using remote control.
 - Low battery.
 - Out of range, move closer to bay.
 - Potential radio interference.
2. My tray extended when my neighbor runs his tray.
 - Change your remote code (see section on setting code).
3. The unit pauses before centering then goes forward and stops.
 - This is normal, it is allowing time for the center latch to move.
4. Unit is not running correctly after working before.
 - May be caused by dead battery. Position tray in center, then reboot system by cycling power to tray.

Manually Retracting Your Cargo Tray



CAUTION

Release lever is spring loaded. Use caution when releasing to prevent injury.

In the event the cargo tray will not function, a manual release lever may be actuated to retract the tray for service.

The lever must be rotated toward the driverside of the coach about 90°. This will allow you to move the tray in for travel.

Once the tray is centered, return the release lever to its normal position to lock the tray in place.

The manual release is meant as a temporary override and service should be scheduled as soon as possible.

