



Omnidirectional Digital HDTV Over-the-Air Antenna



Installation and Operating Instructions

OA1000 • OA1000-OE • OA1010-OE (White)
OA1001 • OA1001-OE • OA1011-OE (Black)

Thank you for choosing a KING Antenna!

The KING OmniPro is an omnidirectional antenna.
It's *always* pointed in the right direction!

OPERATION

- 1** Turn on your TV.
Turn on the power injector.*

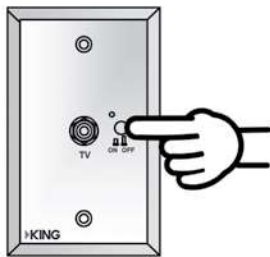

*You must have a properly installed KING wall mount power injector to operate the KING OmniPro.

KING Wall Mount Power Injector for models:

OA1000 • OA1001 (supplied with this product)
OA1000-OE • OA1001-OE (ordered separately)
OA1010-OE • OA1011-OE (ordered separately)

**See your TV or converter box owner's manual for instructions on performing a channel scan.

Installation instructions start on next page.

- 2** Perform a channel scan.**

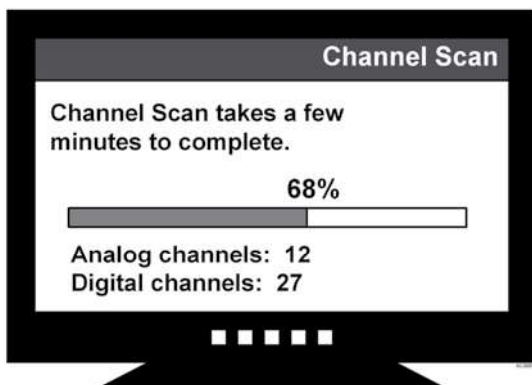

Sample screen: number of channels will vary

- 3** Start watching TV!



ANTENNA INSTALLATION

IMPORTANT! The installer is responsible for determining and supplying the most appropriate fasteners to secure the antenna to the roof, and for weatherproofing all holes with roof-compatible sealant.

All holes and fastener heads must be sealed so they are completely waterproof.

- Select an area on the roof for the base mount keeping in mind the following **IMPORTANT POINTS**:
 - The antenna must be mounted with the coax channel towards the rear of the vehicle.
 - The center of the roof hole must be at least 20" away from any object taller than 8" to provide clearance for the antenna head. The center of the roof hole must also be at least 8" from the edge of the roof.
- Connect the coax from the power injector's antenna input to the coax cable in the base mount. **(The coax may come up thru the roof or enter thru the coax channel.)**
- Apply sealant to the base mount, and fill the coax channel with sealant. Place the base mount in position.
- Fasten the base mount to the roof. Make sure the base mount is sealed all the way around. Make sure the coax channel and fastener heads are sealed as well.

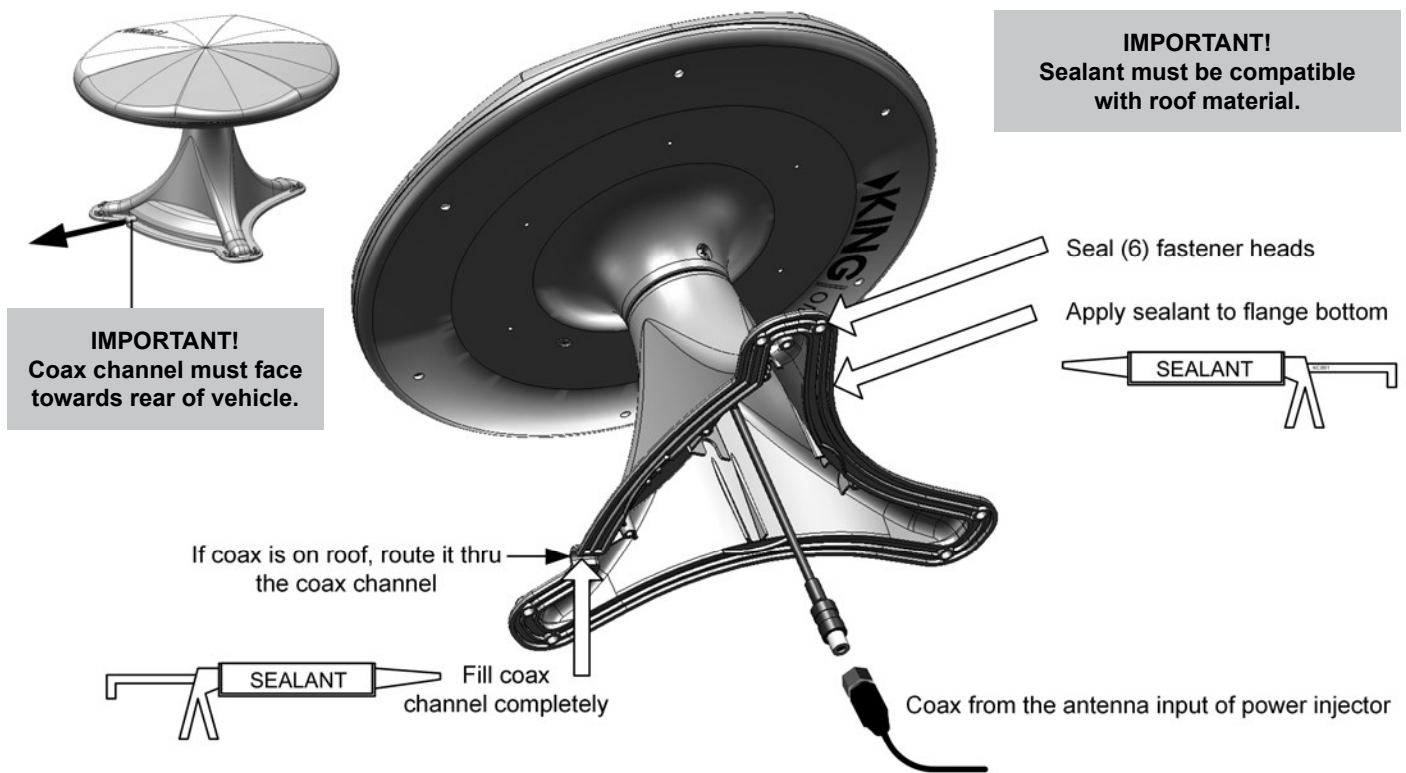

SPECIFICATIONS

SPECIFICATIONS	
Dimensions:	9" H x 13" W x 13" L
Weight:	2.2 lbs.
Frequency Bands:	VHF (54-216 MHz) UHF (470-698 MHz) FM (87.9-107.9 MHz) AM (530-1700 KHz) (OA1010-OE • OA1011-OE only)
Power requirement:	+12 Volt / 100 mA
Power supplied by:	KING Power Injector OA1000 • OA1001 (supplied with this product) OA1000-OE • OA1001-OE (ordered separately) OA1010-OE • OA1011-OE (ordered separately)
Enclosure/Mount:	ASA-Automotive grade

ABOUT THE POWER INJECTOR

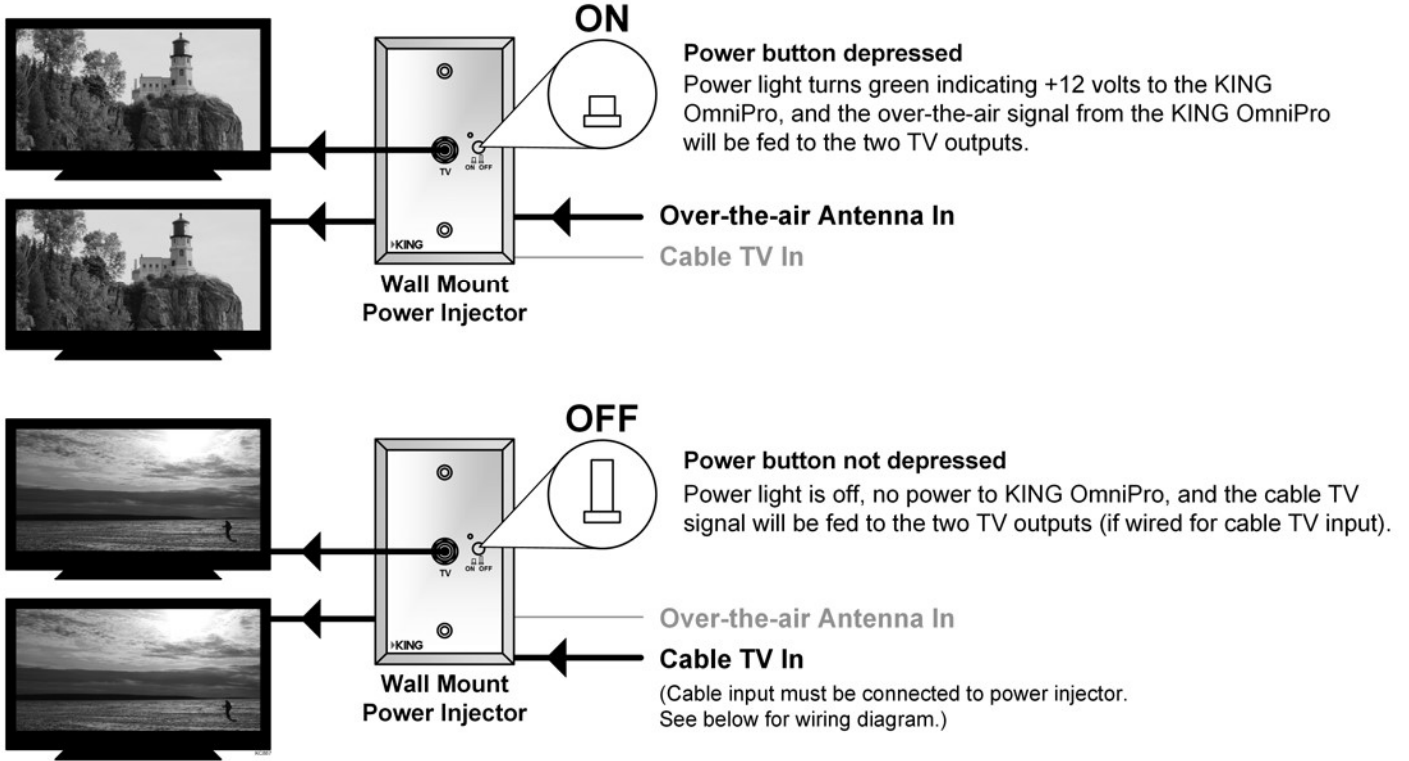

POWER INJECTOR INSTALLATION

Keep in mind the following when installing the Wall Mount Power Injector:

- Can be mounted in most standard electrical boxes.
- Requires a +12 Volt DC power source. (Inadequate voltage may cause the green LED to not illuminate and the unit to not function properly.
- Requires .25" female spade connectors for power and ground connections.
- Has an internal fuse rated @ 400 mA max. If tripped, the fuse will reset when the circuit cools.
- Is not an amplifier. No devices other than those shown below should be connected (unless approved by KING).

