



Read me
FIRST

KENYON®

Make any day a weekend

ALL SEASONS® ELECTRIC GRILL
MANUAL

Table of Contents

Section	Page
Important Safeguards	3
How to Use Grill	
Quick Start Tips	4
Stuffed French Toast	7
Product Specifications	8
Installation Instructions	
Package Contents	9
Electrical Requirements	10
Countertop Installation	10
Drain Connection	13
Outlet Location	13
Final Preparations Prior to Use	13
Operation of Grill	
Touch Control	15
Power Cord	18
Grill Parts	19
Lid Removal	20

IMPORTANT SAFEGUARDS

When using electrical appliances, basic safety precautions should always be followed including the following:

1. Read ALL instructions prior to using product.
2. Do not touch hot surfaces. Use handles or knobs.
3. To protect against electrical shock, do not immerse cord or plugs in water or other liquid.
4. Close supervision is necessary when any appliances are used near children.
5. Unplug from outlet when not in use and before cleaning. Allow to cool before putting on or taking off parts.
6. Do not operate appliance with a damaged power cord or plug. If the appliance malfunctions, discontinue use and contact the nearest authorized appliance dealer or the factory for examination, repair or adjustment.
7. The use of accessory attachments not supplied by the manufacturer of the appliance may cause injuries.
8. When used as a portable grill, store indoors when not in use. When used as a built-in grill, suitable shelter must be provided to prevent direct exposure to rain. Covers available.
9. Do not let cord hang over edge of table or counter, or touch hot surfaces.
10. Do not place on or near a hot gas or electric burner, or in a heated oven.
11. Extreme caution must be used when moving an appliance containing hot oil or other hot liquids.
12. Always attach plug to appliance first, then plug cord into the wall outlet. To disconnect, turn any control to "off", then remove plug from wall outlet.
13. Do not use appliance for other than intended use.
14. Always place a minimum of one (1) cup of water in disposable drip tray prior to grilling.
15. Never leave children alone - children should not be left unattended around the grill at any time.
16. Allow the grill to cool before taking off cooking grates, disposable drip tray or lids.
17. Fuel, such as charcoal briquettes, are not to be used with this appliance.
18. Ensure grill is installed per instructions and properly grounded by a qualified electrician.
19. Do not replace or attempt to repair any part of the grill, unless otherwise noted in this manual. All other service is to be performed by a factory authorized technician.
20. Do not use water to extinguish a grease fire, use dry chemical fire extinguisher.
21. Do not store flammable materials near the grill.
22. Do not wear loose fitting or hanging apparel when using the grill.
23. The appliance is not to be used by persons (including children) with reduced physical, sensory or mental capabilities, or lack of experience and knowledge, unless they have been given supervision or instruction.

WARNING:

Charcoal or similar combustible fuels must be not be used with this appliance.

**PLEASE READ THESE INSTRUCTIONS IN THEIR ENTIRETY
BEFORE INSTALLATION AND USE. SAVE THESE INSTRUCTIONS**

HOW TO USE GRILL

QUICK START TIPS

Thank you for purchasing the World's Finest All Seasons® Electric Grill! There are a few simple steps you can take to ensure your good decision will lead to years of World-Class Grilling:

1. Remove grate(s) and drip tray(s), clean both.
2. Insert the drip tray(s) into the bottom of grill. Make sure the burner brackets are not resting on the drip tray(s).
3. Always fill the drip tray(s) with 16 oz. of liquid. Water will work, but why not try beer or wine to add flavor to your favorite food. Then re-install cooking grate.
4. Depending on model, either hardwire your Kenyon All Seasons® Grill or plug it directly into an outlet, do not use extension cords.
5. Preheat grill for 5 to 9 minutes on high (8 bars). Adjust heat setting for type of food, for example:
 - Vegetables 3-4 bars
 - Pork and fish 4-5 bars
 - Burgers 6-7 bars
 - Steak 7-8 bars
6. Close lid and cook. Enjoy the best grilled food you have ever tasted!
7. Once your grilling session is complete, grab a wet paper towel and wipe down your grate. Once cool, place in the dishwasher along with the dirty dishes so that it's ready for its next tour of duty!
8. While the grate is in the wash, don't forget to clean out the drip tray contents. You don't want your previous juices to flavor your next meal.

VISIT OUR WEBSITE
to purchase recipe books, cooking utensils, griddles, grill covers, and more!



REMOVE & READ PRIOR TO GRILLING

THE ABOVE INSERT IS LOCATED UNDERNEATH YOUR GRILL LID. PLEASE READ INSERT AND REMOVE PRIOR TO GRILL USE.

1. Before using your grill, remove the cooking grate and drip tray from the grill. Wash the grill with warm soapy water using a non-abrasive cloth. **USE ONLY HIGH TEMP PLASTIC UTENSILS WHEN GRILLING.**

2. Make sure the drip tray is inserted all the way into the bottom of grill and electric element brackets are resting on the element support bracket.

3. Cover the bottom of the drip tray with a liquid. Water is fine. **PLEASE**



DO NOT USE A FLAMMABLE LIQUID! Doing so would ruin your cookout. Using apple juice if you are grilling pork adds a nice flavor to the meat. A can of lime soda is wonderful if you are grilling fish. Try any kind of liquid that you enjoy drinking. ***Just remember always add liquid to the drip tray prior to grilling.***



4. To keep your grill smoke free, always clean the grilling surface after each use. Simply wash with warm soapy water using a non-abrasive cloth or place in your dishwasher. Empty the drip tray and wipe with a damp paper towel. The drip tray can be used multiple times before replacement is necessary.



5. Place your cooking grate or optional griddle (part #B96000) onto the element with drip tray installed. Use the griddle for foods such as eggs, pancakes or my favorite - stuffed french toast!

6. Preheat grill for 5 to 9 minutes on high (8 bars illuminated). Adjust heat setting for type of food.
- Steak 7-8 bars
 - Hamburgers 6-7 bars
 - Pork and fish 4-5 bars
 - Vegetables 3-4 bars

7. Close the lid and cook. Enjoy the best grilled food you have ever tasted!

8. Clean up. This is easy to do as you will soon learn. After the grill has cooled to the touch, take a few pieces of paper towel and place on the grilling surface. Pour about one ounce of water on the towel and then using your high temperature nylon tongs, swab the paper toweling back and forth to loosen up the residue from your grilling. Throw the paper towel away and wipe the grate off with a dry paper towel.

9. Once the grate has cooled sufficiently, remove the grate and place in your dishwasher for a thorough cleaning.

10. With the grate removed, lift up the electric element and remove the drip tray. Empty the contents of the drip tray in an appropriate place, please don't pour it on your neighbors lawn. Wipe the tray out with a dry paper towel and reuse the tray. The tray can last for many uses.

11. Every 7-8 uses, you may want to wash the lid. They can be placed in your dishwasher and run on the pots & pans cycle. This will restore your grill to its original pristine look.

12. To clean the grill, first be sure the cooking surface has cooled enough to handle. Then remove the grate, lift up the electric element until it locks in the up position, then the drip tray.

13. Wipe the stainless steel surfaces with a damp cloth to remove any residue from previous grilling sessions.

14. Your Kenyon grill comes with a sample bottle of stainless steel cleaner. Use this cleaner once a month to keep your grill looking like new.



15. The touch control area is ceramic glass which is sealed from the effects of rain, snow and ice. To clean the glass, use a glass cleaner and soft towel. If stains appear, use a ceramic glass cleaner which can be found in your local grocery store.

Stuffed French Toast

16 slices Thin Sliced Bread “any kind but not the white stuff”
1 lb. Cream Cheese (softened)
½ cup Peach Preserves (or your favorite)
4 T. Butter

French Toast Batter:

5 Large eggs thoroughly beaten
1 cup Milk
1 T. Cinnamon, ground
½ t. Allspice, ground
½ t. Coriander, ground
2 oz. Water (Dark Rum, Optional)

In a large bowl, place the eggs and beat with a wire whisk. Add the milk and beat again until incorporated. In a separate smaller bowl pour water or Rum (if you prefer) and add dry ingredients, mix thoroughly. Once the dry ingredients have been mixed, add to the egg and milk mixture and beat again until mixed. By doing this you avoid the clumps that come with making batter.

Method of Preparation:

This will require the use of your griddle. Preheat your ‘All Seasons® Grill’ on medium high heat (6 bars) for approximately ten minutes.

Once the cream cheese has softened, mix with the peach preserves. Divide equally onto eight slices of bread and spread evenly. Place the remaining eight slices on top to make a sandwich. When your griddle has been preheated, add two tablespoons of butter and move around to coat the griddle. Reserve the rest of the butter for the remaining pieces of French Toast. Take the sandwich and dip into the mixture and flip it over to coat both sides of your bread.

Quickly do this to three more “sandwiches”. You will now have four pieces of stuffed French Toast on your griddle.

Be careful not to burn. Flip the sandwiches over and continue cooking until both sides are browned nicely.

At this point you either serve with some nicely warmed maple syrup and butter, or you can keep warm in a low oven until you finish the remaining pieces of French Toast.

PRODUCT SPECIFICATION

This is a general manual for all touch control grills. Your model number may not be listed but the operation and functions are the same.

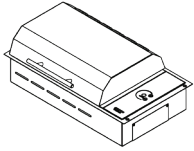

Frontier

Model B70050 - UL Listed - 120V AC - 1300 WATTS - 11 AMPS

Model B70051 - 240V AC - 1300 WATTS - 6 AMPS

Overall dimensions: 21" x 12" x 4" (7 3/8" with lid)
533mm x 305mm x 102mm (187mm with lid)

Depth does not include drain fitting

Cutout dimensions: 19 3/4" x 11 5/8" with 1/4" radius corners
501.6mm x 296mm with 6mm radius corners

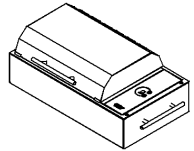

Portable

Model B70090 - UL Listed- 120V AC - 1300 WATTS - 11 AMPS

Overall dimensions: 21" x 12" x 8 5/8"
533mm x 305mm x 219mm

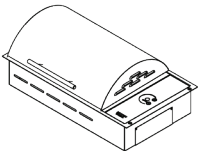

Floridian

Model B70080 - UL Listed- 120V AC - 1300 WATTS - 11 AMPS

Model B70081 - 240V AC - 1300 WATTS - 6 AMPS

Overall dimensions: 21" x 12" x 4" (8 1/8" with lid)
533mm x 305mm x 102mm (206mm with lid)

Depth does not include drain fitting

Cutout dimensions: 19 3/4" x 11 5/8" with 1/4" radius corners
501.6mm x 296mm with 6mm radius corners

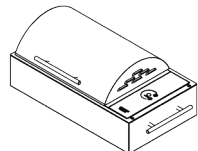

Portable

Model B70082 - UL Listed- 120V AC - 1300 WATTS - 11 AMPS

Overall dimensions: 21" x 12" x 9 3/8"
533mm x 305mm x 238mm

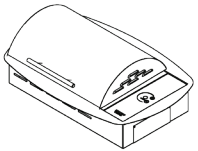

Rio

Model B70085 - UL Listed - 120V AC - 1300 WATTS - 11 AMPS

Model B70086 - 240V AC - 1300 WATTS - 6 AMPS

Overall dimensions: 23" x 15 5/8" x 4" (8 1/8" with lid)
584mm x 397mm x 102mm (206mm with lid)

Depth does not include drain fitting

Cutout dimensions: 19 3/4" x 11 5/8" with 1/4" radius corners
501.6mm x 296mm with 6mm radius corners

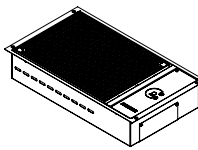

No Lid

Model B70060 - UL Listed - 120V AC - 1300 WATTS - 11 AMPS

Model B70061 - UL Listed - 240V AC - 1300 WATTS - 6 AMPS

Model B70062 - UL Listed - 120V AC - 1300 WATTS - 11 AMPS

Model B70067 - 240V AC - 1300 WATTS - 6 AMPS

Overall dimensions: 21" x 12" x 4"
533mm x 305mm x 102mm

Depth does not include drain fitting

Cutout dimensions: 19 3/4" x 11 5/8" with 1/4" radius corners
501.6mm x 296mm with 6mm radius corners

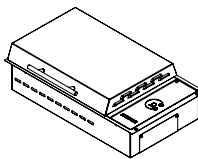

Half Height Lid

Model B70056 - UL Listed - 120V AC - 1300 WATTS - 11 AMPS

Model B70057 - 240V AC - 1300 WATTS - 6 AMPS

Overall dimensions: 21" x 12" x 4" (6 1/4" with lid)
533mm x 305mm x 102mm (159mm with lid)

Depth does not include drain fitting

Cutout dimensions: 19 3/4" x 11 5/8" with 1/4" radius corners
501.6mm x 296mm with 6mm radius corners

INSTALLATION

Package Contents

Your All Seasons® Grill is assembled and ready for use. Before you use the grill write your unit's serial number here for future reference: _____. The serial number can be found on the short side of the grill at the end with the glass control panel. The serial number consists of six digits.

Included in the shipping container is the All Seasons® Grill, four (4) mounting screws, three (3) feet of drain hose, elbow fitting and drain hose for built-in only, manual and stainless steel cleaner. Portable grill drain fitting comes with a plug. If portable grill owners would like to install elbow fitting and hose instead of plug please contact KENYON. If any components are missing or damaged, call KENYON immediately.

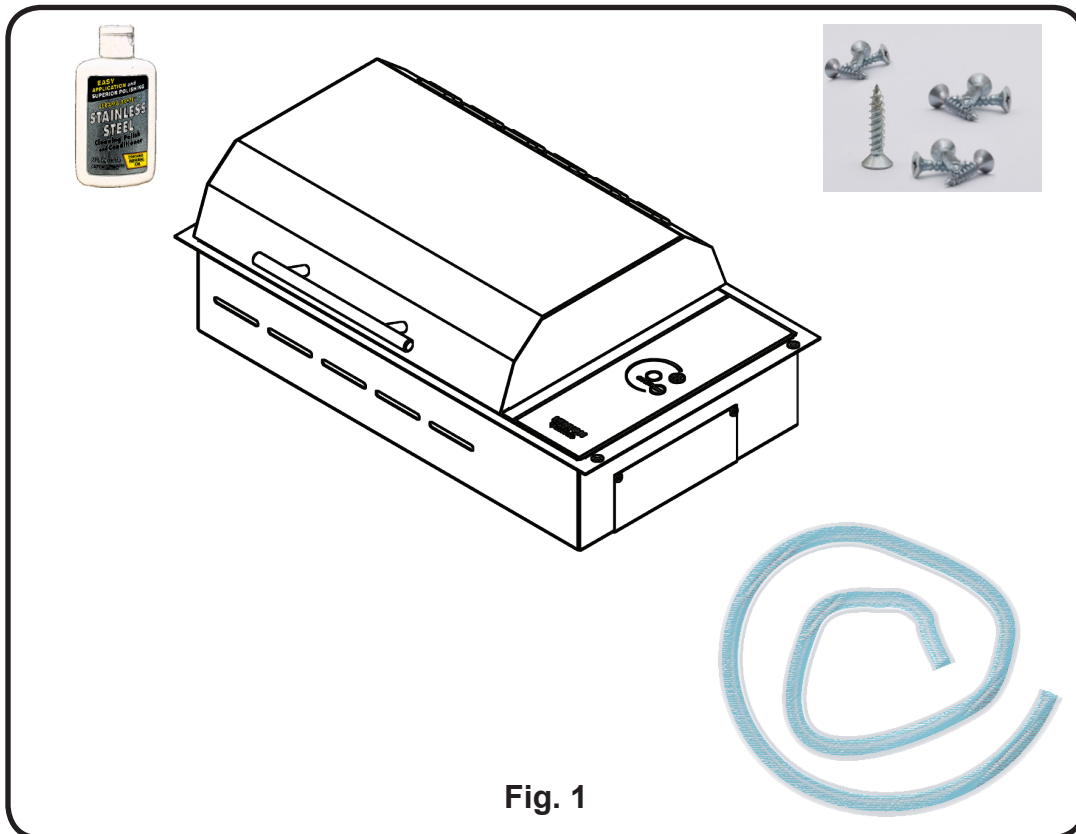

Fig. 1

Electrical Requirements

Check the Electrical Supply Requirements

This product must be installed in accordance with national, state and local electric codes. The following table provides the correct voltage, amperage and frequency that must be supplied to the grill.

The supply must be from an individual grounded circuit that is protected by a circuit breaker and rated per the specifications for the model as shown in the table below.

KENYON Part #	Max Load	Power Supply	Plug Type
B70050 B70056 B70060 B70062 B70080 B70082 B70085 B70090	1300 Watts	120V AC 11A 60Hz	3 prong grounded cord with GFCI
B70051 B70057 B70061 B70067 B70081 B70086	1300 Watts	240V AC 6A 60Hz	3 wire cord no plug

WARNING:

If the electrical supply does not meet the product specifications, consult with a licensed electrician before proceeding with installation!

Do not remove the GFCI device from the supplied power cord under any circumstances.

Countertop Installation

Your All Seasons® Grill is supplied with a factory installed polished stainless steel flange that accepts four oval head wood screws for mounting. The trim flange of the grill is designed to hold the unit firmly in place in the countertop. If desired, you may seal the edge of the countertop beneath the trim flange. **Use a soft bedding compound that will prevent damage if later removal for service is necessary. We recommend a nonadhesive type of sealant, such as plumber's putty, maximum compressed thickness of 1/16".** Silicone may be used to seal the glass edge only, if desired.

WARNING:

Allow a 2 inch (2") minimum clearance between the bottom of the grill and combustible surface located below, ie: the upper edge of a drawer installed below the grill (Fig. 3, page 12). Failure to provide proper clearances and ventilation may result in a fire hazard.

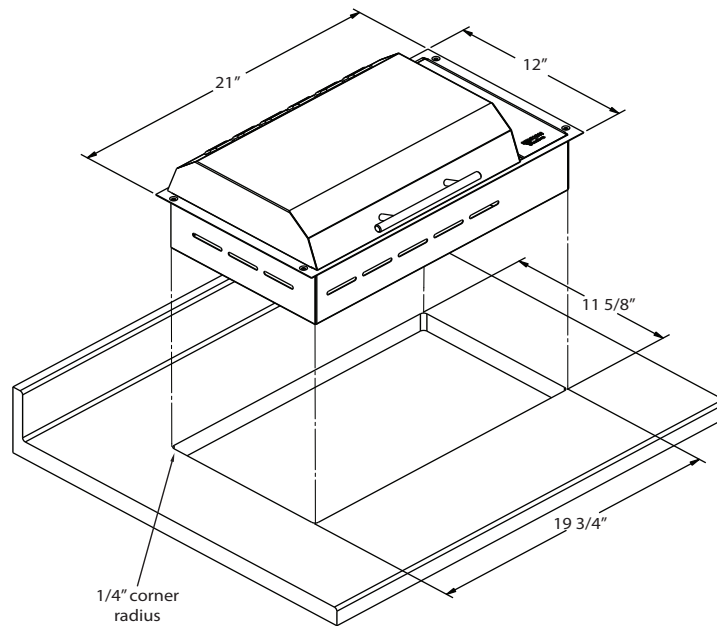

Countertop Cutout DIMENSIONS

B70050 GRILL

Please read this section prior to making cutout for the grill.

It is important to plan ahead for installation of the grill, keeping the following dimensions in mind (please refer to Fig. 2 below).

- A** - 13 inches maximum depth of overhead cabinets
- B** - 36 inches is minimum height of counter top above floor
- C** - The minimum flat countertop surface that the grill will rest upon must be equal to or greater than the overall grill dimensions (refer to the page 8 for overall grill dimensions).
- D** - 30 inches minimum clearance between the top of the grill and the bottom of an unprotected wood or metal cabinet or 24 inch minimum clearance when the bottom of wood or metal cabinet is protected by not less than 1/4 inch thick flame retardant mill board covered with not less than No. 28 MSG sheet steel, 0.015 inch thick stainless steel, 0.024 inch thick aluminum or 0.020 inch thick copper.
- E** - 4 inches minimum from backsplash of countertop to edge of grill (refer to the page 8 for overall grill dimensions).
1-1/2 inches minimum from front of counter to grill.

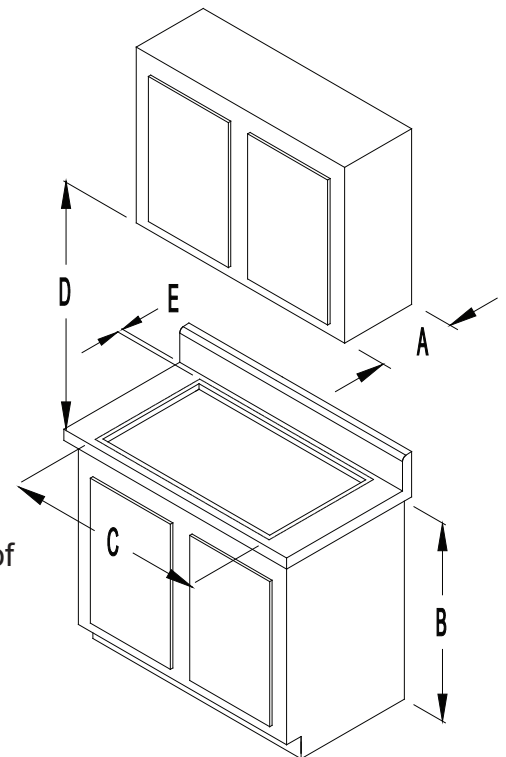

Fig. 2

FOR INSTALLATIONS IN CANADA: “Do Not Install Closer Than 1/2 Inch (12 mm) From Any Adjacent Surface”, and **NE PAS INSTALLER A’MDINS DE 12MM DETOUTE SURFACE ADJACENTE.**

WARNING:

To eliminate the risk of burns from reaching over heated grill, cabinet storage space located above the grill should be avoided. If cabinet storage is to be provided, the risk can be reduced by installing a range hood that projects horizontally a minimum of 5 inches beyond the bottom of the cabinets.

Before making the countertop cutout, check for clearance. Check to see that the grill will clear the front and side walls of the base cabinet. Also check for proper clearance to the back splash so that the lid can open fully.

Adequate ventilation of the space below the countertop must be provided to ensure proper operation of the grill. Heat transferred from the grill bottom pan during operation will overheat an improperly ventilated area.

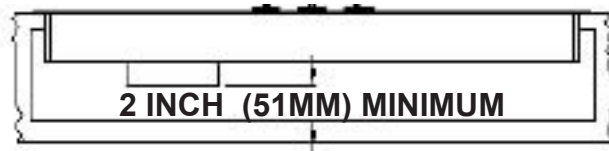

Fig. 3

When making countertop cutout, radius the corner to help prevent cracking of the countertop material. A 1/4 inch radius is typical, but follow the countertop manufacturer's instructions regarding the minimum radius and any reinforcements required to prevent damage to the countertop over time.

If your countertop is made of solid surface material you will need to check with the manufacturer for specific recommendations for cooktop & grill installation instructions. Most solid surface countertop manufacturers require additional corner supports to prevent damage to the countertop. Use the included screws to secure the grill to the countertop. Be careful not to over-tighten the screws. Use an acrylic caulk to seal the flange to the countertop.

If your countertop is made of stone you will need to use an acrylic latex to mount the grill in place. Put a large bead of caulk around the cutout opening and put the grill in place. Wipe away any excess caulk, use water to remove the excess caulk. Allow the caulk to dry for a minimum of 24 hours without any moisture being allowed to come in contact with the caulk. Do not use the screws that came with your grill. The caulk will hold the grill securely. Do not use a caulk which contains silicone as this will stain the stone.

Drain Connection

For your convenience, the grill is equipped with a 1/8" NPT brass pipe fitting and 90° brass elbow which you can attach the 1/4" ID flexible hose that came with your grill. The portable version of the grill comes with a brass pipe plug installed in the drain fitting. If you are using your grill as a portable unit, save the hose and 90° brass fitting for possible installation in the future.

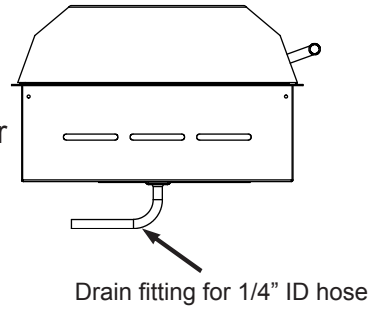
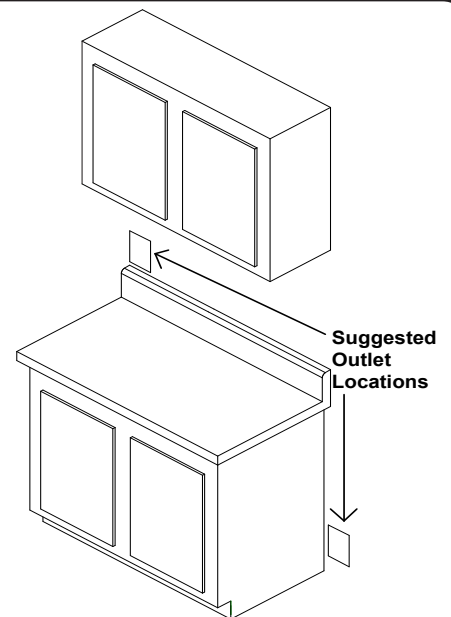

Fig. 4

Outlet Location

Be sure the electrical outlet intended for the grill is in an easily accessible location. This allows the user to easily plug and unplug the grill. This is necessary to ensure safe cleaning and storage of the grill.



Final Preparations Prior to Use

Remove the protective plastic film from the lid, trim flange and glass panel. Clean the grill before you use it for the first time. A thorough cleaning with a stainless steel or glass cleaner will remove any traces of plastic film adhesives and manufacturing oils.

Wash the nonstick coated grates in warm soapy water before using the grill.

OPERATION OF GRILL

DO NOT USE WATER ON GREASE FIRES

Smother fire or flame or use dry chemical or foam-type extinguisher.

USE ONLY DRY POT HOLDERS

Moist or damp pot holders on hot surfaces may result in burns from steam. Do not let pot holder touch the grate or element of the grill. Do not use a towel or other bulky cloth in place of a pot holder.

DO NOT COOK ON BROKEN GRILL GRATE OR GRIDDLE

If the grate should break, grease and oils may come into direct contact with the electric element and create a risk of electric shock or fire. Contact an authorized service center or KENYON Customer Care immediately at (860) 664-4906.

CLEAN GRILL WITH CAUTION

If a wet sponge or cloth is used to wipe spills on a hot cooking surface, be careful to avoid steam burns. Some cleaners produce noxious fumes if applied to a hot surface. Read the cleaner label for details prior to using.

DO NOT TOUCH HEATING ELEMENT OR GRATE

The heating element and grate will be hot for some time after cooking. These components should be allowed to cool and then be handled with care and caution while cleaning, as they may be hot enough to cause severe burns.

CLEAN GRILL AFTER EACH USE

This appliance is equipped with a removable, disposable drip pan. This pan **MUST** be removed and cleaned after each and EVERY use. Do not allow grease to accumulate between cooking. The grease pan and baffle tray **MUST** be used when cooking on the grill. Excessive grease may spill over into the interior of the grill, voiding your warranty and posing a fire hazard.

NEVER LEAVE GRILL UNATTENDED AT HIGH HEAT SETTINGS

High heat setting may cause heavy smoking and ignite grease.

DO NOT CLEAN UNIT WITH PRESSURIZED WATER

Never clean the grill with any form of pressurized water or other types of cleaners. Doing so will void the warranty and may pose a serious risk of electric shock. Always clean the grill with a cloth and a stainless steel or glass surface cleaner.

STORAGE

When used as a portable grill, store indoors when not in use. When used as a built-in grill, suitable shelter must be provided to prevent direct exposure to rain. Covers available.

TO PREVENT SMOKE

To prevent the contents of the grease pan from smoking, place 1 cup of water (or enough to cover the bottom of the pan) in the grease pan before cooking.

DO NOT USE POTS OR OTHER BAKEWARE ON THE GRILL

KEEP THESE INSTRUCTIONS WITH THE GRILL FOR FUTURE REFERENCE

Touch Control

POWER ON INDICATOR

This display indicates whether the grill is ON or OFF.

POWER LEVEL DISPLAY

Digital display indicates heat output of grill. The indicator lamps follow the sweep of the screened graphic. There are eight possible heat levels.

(+) POWER SENSOR

Touching this sensor will increase the heat output of the grill in increments of one.

(-) POWER SENSOR

Touching this sensor will decrease the heat output of the grill in increments of one.

POWER LEVEL GRAPHIC

Depicts the level of heat output by the element. The line sweeps from thin to thick, indicating low to high power.

MASTER POWER SENSOR

This is the main power control for the grill. Touching this with the grill OFF will activate the controller and turn the grill ON. Touching this sensor with the grill on will shut the grill OFF.

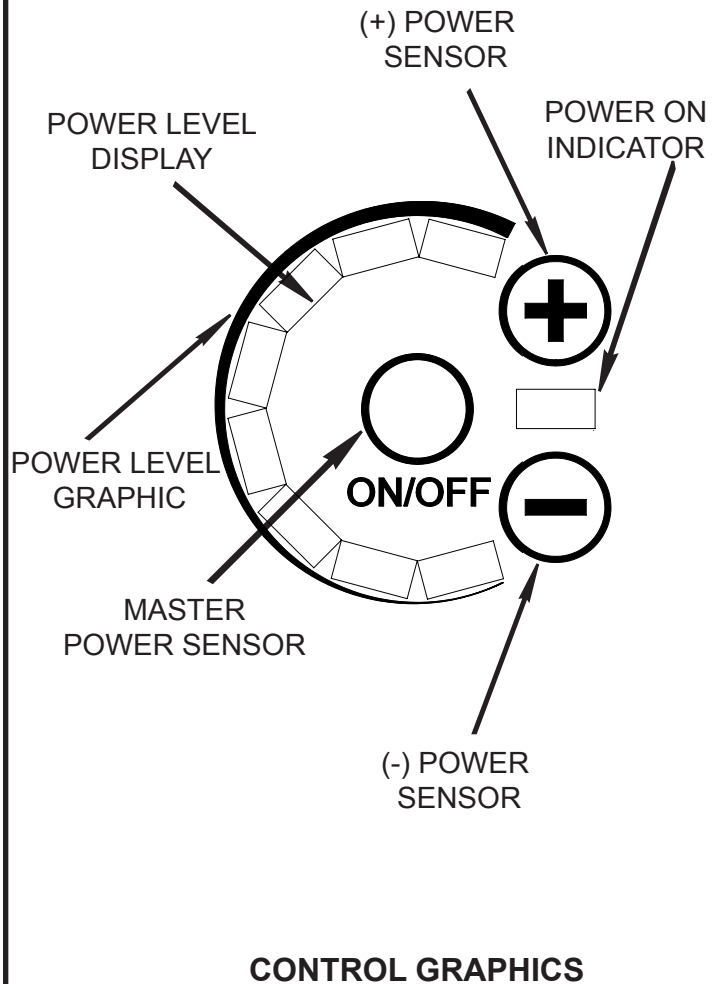

CALIBRATION

Upon application of electrical power to the grill, the controller will run a self-calibration process. The controller will then sound an audible confirmation tone and the display will briefly illuminate. The grill is now ready to be used.

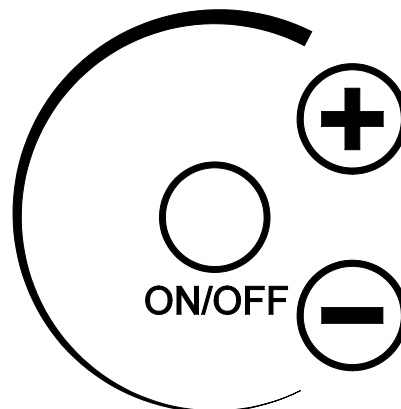

ENERGIZING THE GRILL

To turn the grill ON, touch and hold the Master Power Sensor for two seconds. The controller will then beep and the Power On Indicator will illuminate.

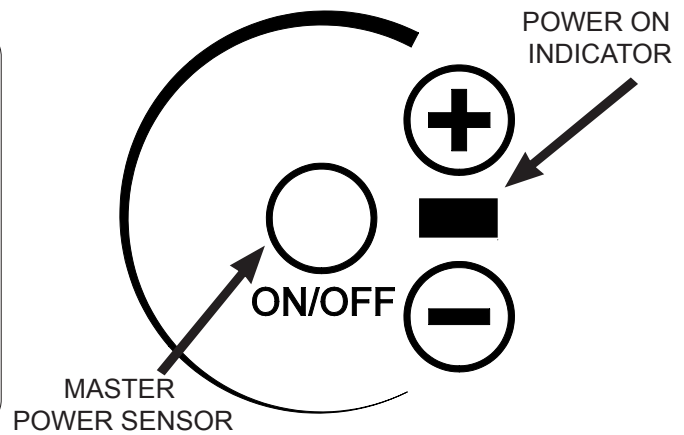

HEAT SETTINGS

Your KENYON grill has 8 different heat settings, from 1 through 8, selected using the (-) and (+) sensors. The heat setting is displayed as shown at the right. The heating element cycles at different time intervals to vary the heat level. As the setting is increased, the heating element will remain on for a longer period, increasing the cooking temperature of the grill.

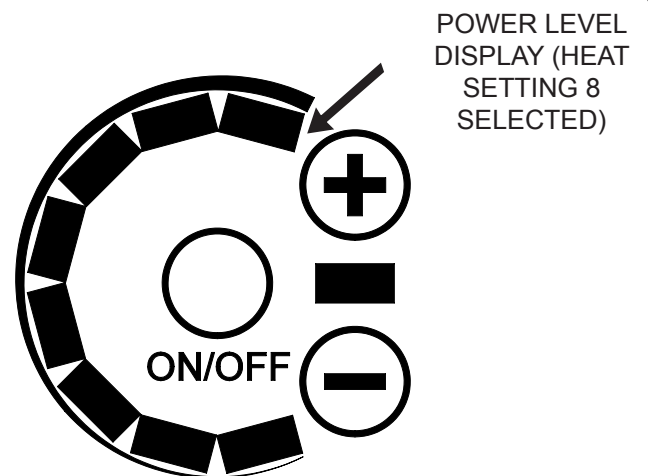

TURNING "OFF" THE GRILL

To turn off the grill, simply **touch and hold** the Master Power Sensor for **two seconds**. The controller will de-energize and shut off the heating element.

IN AN EMERGENCY THE 120V GRILL CAN BE TURNED OFF BY PRESSING THE "TEST" BUTTON ON THE GFCI. REFER TO FIG. 5.

AUTOMATIC SHUT-OFF

The electronic control of your KENYON grill has been programmed with safety in mind and features an automatic shut-off. The grill is programmed to shut down after a predetermined time after being energized (see table below). The control will also shut off if it reaches a preset temperature limit. If this occurs, allow the grill to cool down for 20-30 minutes.

PREHEAT AND AUTO SHUT-OFF TIME

The grill control has a preheat function which applies full power for a set amount of time for each power setting selected. This preheat function brings the grate/griddle to the desired grilling temperature quicker thus allowing you to begin grilling quicker. The table below provides the preheat time and auto shut-off time for each power setting.

SETTING	PREHEAT TIME (min)	AUTO SHUT-OFF (min)
1	1	90
2	3	90
3	5	90
4	5	60
5	7	60
6	7	60
7	7	60
8	8	60

TEMPERATURE GUIDE

The following is meant to be a guideline. Factors such as wind, and outside temperatures, food temperature when placed on grill can affect cooking times. The grill is designed and engineered for optimal cooking performance with the lid down or closed.

SETTING	FOOD TYPES
1	Fried eggs on griddle
2	Pancakes - French toast on griddle
3	Vegetables
4	Vegetables - Fish
5	Fish - Chicken
6	Chicken - Hamburgers
7	Hamburgers - Steaks
8	Steaks

Power Cord

THIS PERTAINS TO 120V MODELS ONLY

GROUND FAULT CIRCUIT INTERRUPTER (GFCI)

The GFCI is a safety device designed to protect the user from any electrical shock hazard.

INDICATOR LIGHT

The indicator light will stay illuminated when electrical power is applied and indicates that the GFCI is working properly.

TEST/EMERGENCY OFF BUTTON

Pressing this button will test the GFCI. The indicator light will go out and electrical power will not be supplied to the grill. The GFCI should be tested monthly.

RESET BUTTON

Pressing this button will reset the GFCI to its normal function. The indicator lamp will illuminate and electrical power will be supplied to the grill. If the indicator lamp does not illuminate, the GFCI has detected a malfunction. Unplug the GFCI from the receptacle and do not use the grill.

GROUNDING 3-PRONG PLUG

CAUTION - To ensure continued protection against risk of electric shock, the GFCI must be plugged into a properly grounded receptacle.

DO NOT USE AN EXTENSION CORD

240V MODELS

GROUND FAULT CIRCUIT

The supply voltage circuit (240V) should be equipped with a ground fault circuit interrupter. Check local codes for compliance.

GROUNDING 3-PRONG PLUG

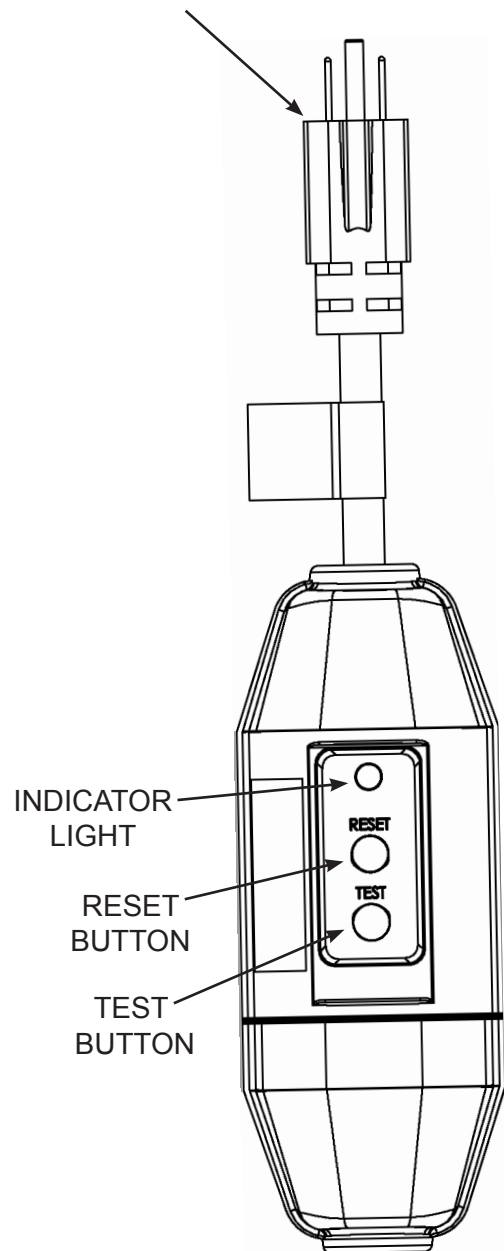

GROUND FAULT
CIRCUIT INTERRUPTER
GFCI

Fig. 5

Grill Parts

HEATING ELEMENT

The heating element is designed to pivot as shown to remove/replace the baffle tray and drip tray. It will stay in the up position. To put down apply slight downward pressure.

BAFFLE TRAY

The baffle tray supports the drip tray, heating element and grate and must always be used when operating the grill.

DRIP TRAY

The disposable drip tray collects all the fat and juices created during the cooking process. The drip tray must be emptied after each use. When replacing the drip tray, position the drip tray so that it is completely contained inside the baffle tray and insuring that the side or the rim of the drip tray does not protrude outside of the baffle tray. (see Fig. 6)

To prevent the contents of the drip tray from smoking, place 1 cup of water (or enough to cover the bottom of the pan) in the drip tray before cooking. The replacement for the disposable drip tray is Kenyon part #B96001.

GRATE

The grate must be cleaned after every use. The grate has a nonstick coating for ease of cleaning. Wash the grate after each use in warm soapy water.

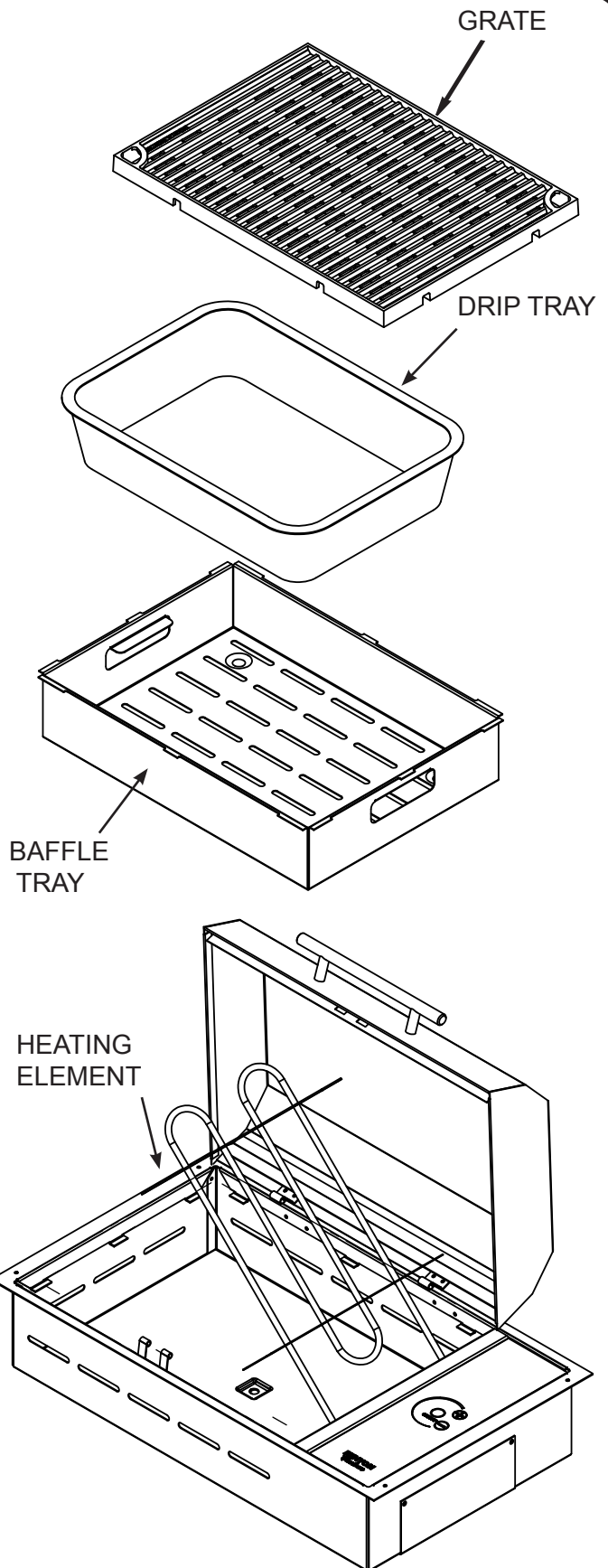
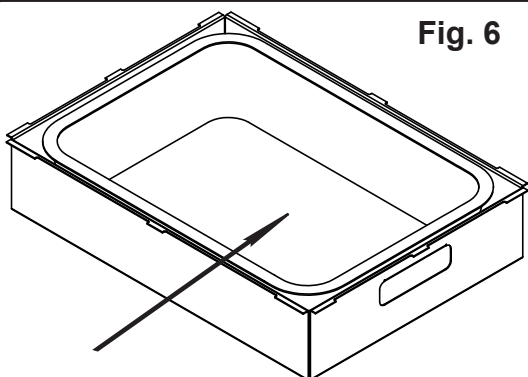

Fig. 6



DRIP TRAY MUST BE CONTAINED INSIDE OF BAFFLE TRAY AS SHOWN

Lid Removal

LID REMOVAL

The grill lid is removable for cleaning. To remove the lid, slide the quick release pin out of the hinge. (see Fig. 7)

With the quick release pin removed, grasp the lid, lifting on the left side to clear the hinge and slide it the left until clear of the hinge pin on the right. (see Fig. 8) Once the lid is removed, it can be washed in warm, soapy water.

Fig. 7

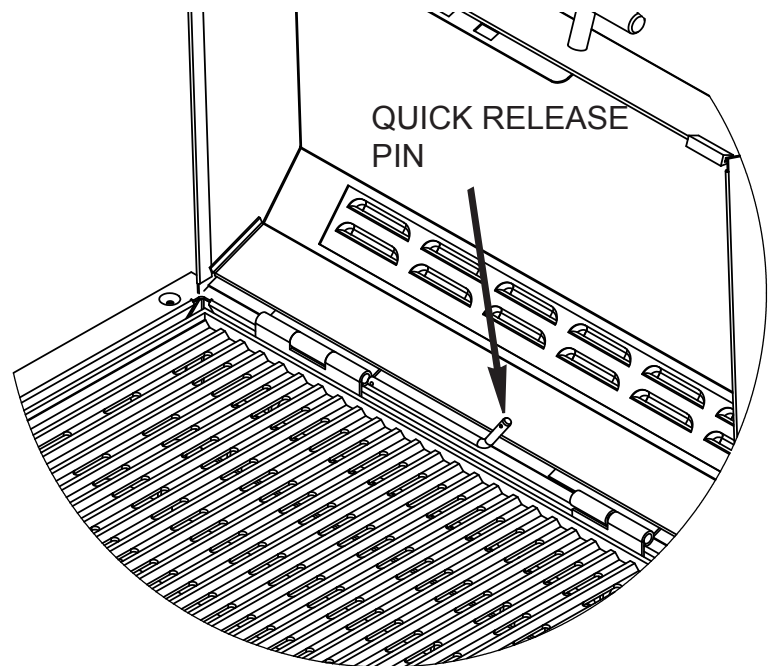

Fig. 8

