

Thank you for purchasing IOTA's SDC1 Solid-DC Series [Power Converter/Battery Charger](#). When utilized properly, your SDC1 Power Converter/Battery Charger will provide years of dependable service. This Owner's Manual contains important safety and operating instructions. **READ ALL INSTRUCTIONS AND SAFETY PRECAUTIONS CAREFULLY BEFORE IN-STALLING AND OPERATING THE UNIT.**

WARNING

Risk of SERIOUS INJURY OR DEATH

This unit is an electrical device. When working with this, or any electrical device, there exists the potential for **ELECTRICAL SHOCK, EXPLOSION and FIRE hazards.**

Before using this equipment, **READ AND UNDERSTAND** the instructions, warnings, and safety precautions in this Owner's Manual. Failure to read and understand these instructions could result in **SERIOUS INJURY** or **DEATH**.

SAVE THESE INSTRUCTIONS

CAUTION

When working with the SDC1 unit, always observe the following guidelines:

- The SDC1 is designed for indoor use. Do not use outdoors.
- **DO NOT** expose the SDC1 unit to rain, snow, or other inclement weather.
- Do not mount the SDC1 in a zero clearance compartment or in compartments with flammable items such as gasoline or batteries.
- Do not mount the SDC1 in an area with the potential of dust, debris, or other foreign materials entering the vents of the SDC1.
- Use of an attachment or device with the SDC1 not recommended by IOTA Engineering will void the warranty and may result in a risk of fire, electrical shock, or injury to persons.
- To reduce the risk of damage to the electric plug and cord, always pull by the plug and not the cord when disconnecting the unit.
- **DO NOT** operate the SDC1 with a damaged cord or plug.
- **DO NOT** operate the SDC1 if it has been dropped, received a sharp blow, or has been otherwise damaged in any way.
- **DO NOT** disassemble the SDC1 unit.
- To reduce the risk of electric shock, **DISCONNECT** the SDC1 charger from **ALL** power sources before attempting any maintenance or cleaning. Turning off any electrical supply or load to the unit is not sufficient and will not reduce this risk.
- **DO NOT** use extension cords. Using an improper extension cord could result in a risk of fire and electric shock, and may result in property damage, personal injury or death.

DANGER

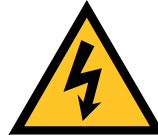

ELECTRICAL SHOCK HAZARD

THIS CHARGER IS AN ELECTRICAL DEVICE THAT CAN SHOCK AND CAUSE SERIOUS INJURY.

DO NOT CUT POWER CORDS.

DO NOT SUBMERGE IN WATER OR GET THE CHARGER WET.



EXPLOSION HAZARD

UNSUPERVISED, INCOMPATIBLE, OR DAMAGED BATTERIES CAN EXPLODE IF USED WITH A CHARGER.

DO NOT ATTEMPT TO CHARGE DAMAGED OR FROZEN BATTERIES.

USE THE CHARGER ONLY WITH BATTERIES OF RECOMMENDED VOLTAGE.

OPERATE THE CHARGER IN WELL-VENTILATED AREAS ONLY.

WARNING



FIRE HAZARD

A CHARGER IS AN ELECTRICAL DEVICE THAT EMITS HEAT AND CAN BURN.

DO NOT COVER THE CHARGER.

KEEP THE CHARGER AWAY FROM COMBUSTIBLE MATERIALS.

DO NOT SMOKE OR USE ANY OTHER SOURCE OF ELECTRICAL SPARK OR FIRE WHEN OPERATING THE CHARGER.



RISK OF EXPLOSIVE GASES

WORKING IN THE VICINITY OF LEAD-ACID BATTERIES IS DANGEROUS. BATTERIES GENERATE EXPLOSIVE GASES DURING NORMAL BATTERY OPERATION. FOR THIS REASON, IT IS OF UTMOST IMPORTANCE THAT YOU FOLLOW THE INSTRUCTIONS WHEN USING THE BATTERY CHARGER.

To reduce the risk of battery explosion, follow these instructions and those published by the battery manufacturer and review all Cautions and Warnings associated with these products.

PRODUCT DESCRIPTION

IOTA SDC1 Solid-DC Series Power Converter/Battery Chargers convert 120 volts nominal A.C. to 13.6 volts D.C. As a power supply, its tightly controlled regulation allows the user to operate any 12 volt nominal D.C. load up to the converter's rated output current. As a battery charger, the converter will maintain the battery, delivering its full-rated current when the battery capacity falls sufficiently low. The voltage is set to deliver its maximum current for the necessary period of time that minimizes undue stress to the battery caused by heating of its cells. This helps to ensure the longest possible life of the battery. Over time, as the battery nears its full capacity, the converter will float-charge the battery to prevent self-discharge of its cells.

PROTECTION FEATURES

The IOTA Power Converters/Battery Chargers are designed with high quality components to help ensure years of continuous use. The unit is protected by multiple protection features for a long, trouble-free life.

1) *Reverse Battery Polarity Protection.* 2) *Brown-Out Input Protection.* 3) *Over-Current Protection* - cycle by cycle peak limiting as well as rated current limiting to maximize the life of the converter. 4) *Over-Temperature Protection.* In addition, it is designed with a unique "proportional" fan control circuit. Fan speed is directly proportional to the converter's internal ambient temperature. This enables the fan to turn on and off very slowly, minimizing unwanted fan-starting noise.

INSTALLATION GUIDELINES

MOUNTING LOCATION

The IOTA Power Converter/Battery Charger can be mounted in any position within an enclosed or interior compartment. Provide sufficient air space to allow unrestricted airflow in and around the unit. Provide at least 4" around the fan of the SDC1 to allow for proper air intake.

DO NOT mount the unit in a zero clearance compartment.

DO NOT mount the SDC1 in the same compartment with flammable items such as gasoline or batteries. There are no components within the SDC1 unit that, during normal operation, produce arcs or sparks. However, all electronic devices have some potential for generating sparks in the event of failure which can result in explosion or fire.

DO NOT mount the SDC1 in an area that has the potential of dust, debris, or other foreign materials to enter in through the SDC1 vents.

DO NOT place the SDC1 directly above the battery; the gases from the battery can corrode and damage the SDC1.

INSTALLATION GUIDELINES (cont.)

BATTERY CONNECTION

Before you connect the SDC1 to the battery, make sure that the AC power cord is NOT plugged into an electrical outlet.

Disconnect the positive side of the battery before installation. Connect the positive and negative terminal lugs to battery or load. Always use the proper size wire based on the amperage of the converter and the battery. Torque the connections to the proper rating according to the wire manufacturer's specifications. Refer to Illustration 1. Recreational vehicle applications require a type III circuit breaker be installed within 18" of the battery, connecting the battery positive to the line side of the breaker, and the IOTA unit to the load side. Connect "Chassis Bonding Lug" on the IOTA unit to vehicle chassis or other grounding source. Refer to Illustration 1.

120 VOLT A.C. INPUT

Plug the unit A.C. input cord into an appropriate 120-volt 3-wire grounded source. The blue LED indicator light will illuminate, indicating the presence of AC power. Refer to Illustration 2 for specifications of the cord provided with your SDC1 unit. See the Technical Specifications Chart on page 4 for maximum current draw and required input voltages.

DO NOT USE EXTENSION CORDS - Using an improper extension cord could result in a risk of fire and electric shock, and may result in property damage, personal injury or death.

DO NOT OPERATE THE SDC1 WITH A DAMAGED CORD OR PLUG. Have the cord or plug replaced immediately by qualified service personnel.

REVERSE POLARITY FUSES

The IOTA Battery Charger/Power Supply is protected against reverse polarity on the DC output. If a battery or the unit is hooked up incorrectly, the fuses will blow and can be easily replaced. Always use the same size and style fuse that came with the converter.

NOTE: Depending on the amperage model of the SDC1, fuses may not be present in all slots. Refer to the chart below for the rating and number of fuses per model:

Model	Fuse Rating	Fuse Quantity
SDC1-120-12-15	7.5A	2
SDC1-120-12-30	15A	2
SDC1-120-12-45	25A	2
SDC1-120-12-55	20A	3
SDC1-120-12-75	25A	3
SDC1-120-12-90	30A	3

WARRANTY



The IOTA Solid-DC Power Converters/Battery Chargers are warranted from defects in materials or workmanship for three years from date of retail purchase, and limits the remedies to repair or replacement. This warranty is valid only in the continental United States and Canada.

ILLUSTRATION 1 - SDC1 CONNECTIONS*

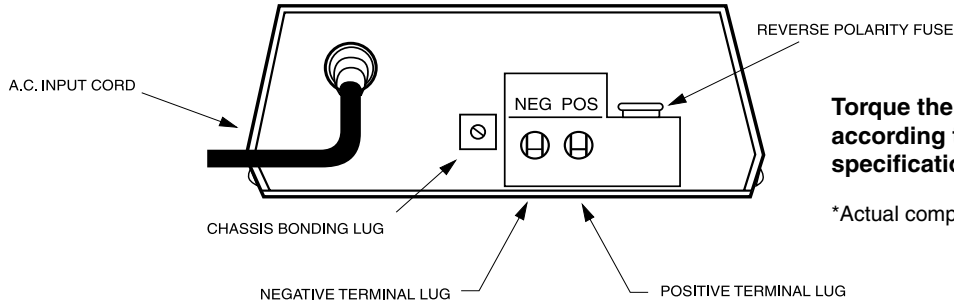

Torque the connections to the proper rating according to the wire manufacturer's specifications.

*Actual component locations may vary depending on model.

ILLUSTRATION 2 - AC INPUT PLUG

SDC1-120-12-15, SDC1-120-12-30,
SDC1-120-12-45, SDC1-120-12-55

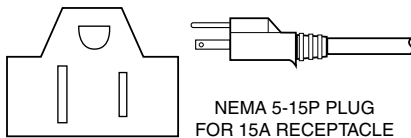

SDC1-120-12-75

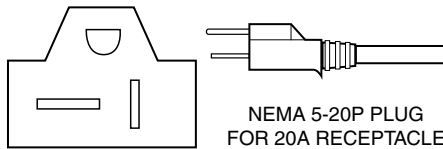

SDC1-120-12-90 (UL Models)

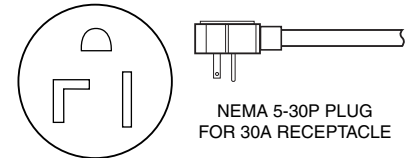

SDC1-120-12-90 (Non-UL Models)

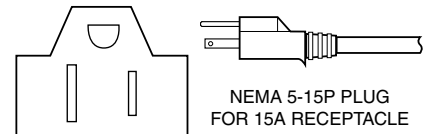

ACCESSORY PORT AND AMPLIFE CHARGE CONTROL MODULE

The SDC1 features an accessory port on the fan end of the unit for installing an AmpLife Charge Control Module for automatic four-stage charging.

Installing the AmpLife Charge Control Module gives the user the benefit of automatic Bulk, Absorption, and Float stage charging. This increases the charging capacity of the IOTA charger, decreases charge times and insures proper and safe battery charging without over-charging. The green LED on the module will indicate which charging phase the IOTA charger is currently in. When the unit is first activated, the LED will flash as it reads the number of cells in the battery. The unit will then proceed directly to the Bulk charging or Float charging phase depending on the charge status of the battery. Use the LED CODE TABLE for reference when checking the LED.

To install an AmpLife module into the charger, remove the fastening screw on the top of the port faceplate and detach the faceplate. Plug the control module into the port and secure in place using the original fastening screw. NOTE: the port faceplate and AmpLife control module are similar in appearance. You can recognize the AmpLife Charge Control Module by the presence of the LED indicator on the face.

ILLUSTRATION 3 - AMPLIFE MODULE INSTALLATION

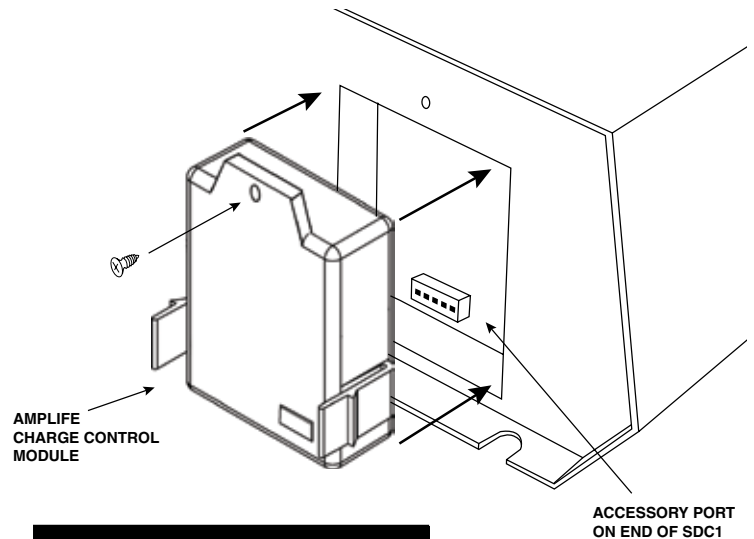

LED CODE TABLE

CELL INDICATION		
6 FLASHES	12V Battery (6 cells)	
12 FLASHES	24V Battery (12 cells)	
18 FLASHES	36V Battery (18 cells)	
24 FLASHES	48V Battery (24 cells)	
CHARGE PHASE	LED STATUS	VOLTAGE RATE
FLOAT	ON	2.266 PER CELL
ABSORPTION	SLOW FLASHING	2.366 PER CELL
BULK	RAPID FLASHING	2.466 PER CELL

TECHNICAL SPECIFICATIONS CHART

RATINGS AND SPECIFICATIONS	SDC1-120-12-15	SDC1-120-12-30	SDC1-120-12-45	SDC1-120-12-55	SDC1-120-12-75	SDC1-120-12-90
DC Output Voltage (No Load) approx.	13.6V (DC)	13.6V (DC)	13.6V (DC)	13.6V (DC)	13.6V (DC)	13.6V (DC)
Output Voltage Tolerance (No Load)	+ or - .7%	+ or - .7%	+ or - .7%	+ or - .7%	+ or - .7%	+ or - .7%
Output Amperage, Max Continuous	15 Amps	30 Amps	45 Amps	55 Amps	75 Amps	90 Amps
Output Voltage (Full Load) approx.	>13.4V (DC)	>13.4V (DC)	>13.4V (DC)	>13.4V (DC)	>13.4V (DC)	>13.4V (DC)
Maximum Power Output, Continuous	200 Watts	450 Watts	650 Watts	800 Watts	1125 Watts	1350 Watts
Ripple and Noise	<50 mV rms	<50 mV rms	<50 mV rms	<50 mV rms	<50 mV rms	<50 mV rms
Input Voltage Range	108 - 132 AC	108 - 132 AC	108 - 132 AC	108 - 132 AC	108 - 132 AC	108 - 132 AC
Input Voltage Frequency	47-63	47-63	47-63	47-63	47-63	47-63
Maximum AC Current (@ 108Vac)	3.7 Amps	7.3 Amps	11 Amps	13.4 Amps	18.2 Amps	21.8 Amps*
Typical Efficiency	>80%	>80%	>80%	>80%	>80%	>80%
Max Inrush Current, Single Cycle	30 Amps	30 Amps	30 Amps	30 Amps	40 Amps	40 Amps
Short Circuit Protection	Yes	Yes	Yes	Yes	Yes	Yes
Overload Protection	>100%	>100%	>100%	>100%	>100%	>100%
Line Regulation	100 mV rms	100 mV rms	100 mV rms	100 mV rms	100 mV rms	100 mV rms
Load Regulation	<1%	<1%	<1.5%	<1.5%	<1.5%	<1.5%
Fan Control	PROPORTIONAL	PROPORTIONAL	PROPORTIONAL	PROPORTIONAL	PROPORTIONAL	PROPORTIONAL
Thermal Protection	YES	YES	YES	YES	YES	YES
Working Temperature Range	0° - 40° C	0° - 40° C	0° - 40° C	0° - 40° C	0° - 40° C	0° - 40° C
Storage Temperature	-20° to 80° C	-20° to 80° C	-20° to 80° C	-20° to 80° C	-20° to 80° C	-20° to 80° C
Withstand Voltage (VDC) [†]	1700/1700/500	1700/1700/500	1700/1700/500	1700/1700/500	1700/1700/500	1700/1700/500
Approximate Dimensions	10.3" x 6.0" x 2.7"	10.3" x 6.0" x 2.7"	10.3" x 6.0" x 2.7"	10.3" x 6.0" x 2.7"	12.1" x 7.75" x 2.9"	12.1" x 7.75" x 2.9"
Weight	4.5 lbs	4.5 lbs	5.0 lbs	5.0 lbs	8.0 lbs	8.0 lbs

*Requires 30A breaker

[†]Primary to Chassis/Primary to Secondary/Secondary to Chassis

