

Mounting Bracket Kit: Kick-Down Jacks

Application: For mounting Kick-Down Jacks on the REAR OF CHEVY P30 chassis prior to 1993, 1993 and later WORKHORSE and P30 chassis with GVWR's OF 11,000# and 12,300# only, some 1993 P30 chassis with GVWR's OF 14,500# and 16,000# with SPRING OVER SPRING HANGER.

This bracket is NOT to be used on chassis with the spring mounted under the spring hanger.

Mfr. #: AP5272 Bracket Kit Chevy/Workhorse Rear

- Includes:**
- 1 - AP8710 Bracket Left Rear
 - 1 - AP8711 Bracket Right Rear
 - 1 - AP5276 Hardware Kit

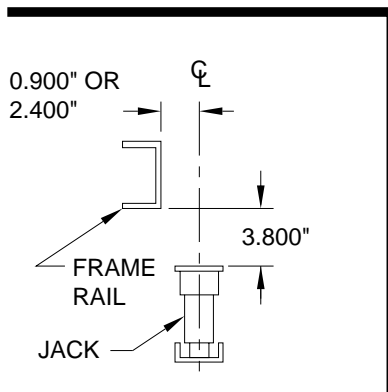
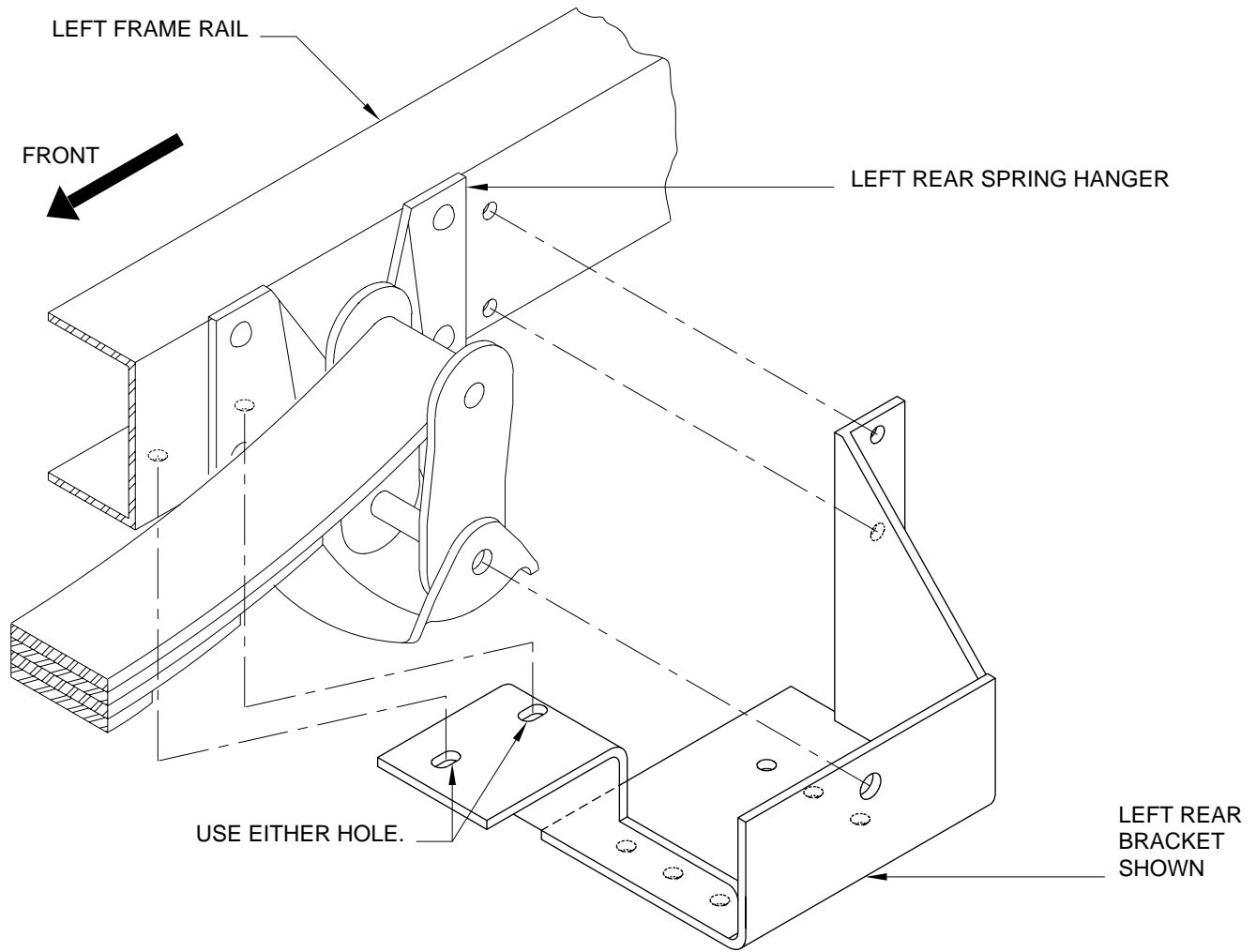

NOTE: IF JACK IS TOO CLOSE TO TAIL PIPE, HAVE COACH OWNER TAKE COACH TO A PROFESSIONAL MUFFLER SHOP.

NOTE: DO NOT USE THIS BRACKET UNLESS THERE IS A CHASSIS MANUFACTURER'S CROSSMEMBER BY THE SPRING HANGER OR WITHIN 20" TO THE FRONT OF THE SPRING HANGER.

CAUTION: Follow CAUTIONS in Operator's and Installation Manuals concerning working under vehicles.

CHECK RECOMMENDED MOUNTING HEIGHT OF JACK BEING USED.