

INSTRUCTION SHEET

LEVELEZE® LIGHT PACKAGE INSTALLATION/ADJUSTMENT

INSTALLATION

1. ELECTRICAL CONNECTIONS

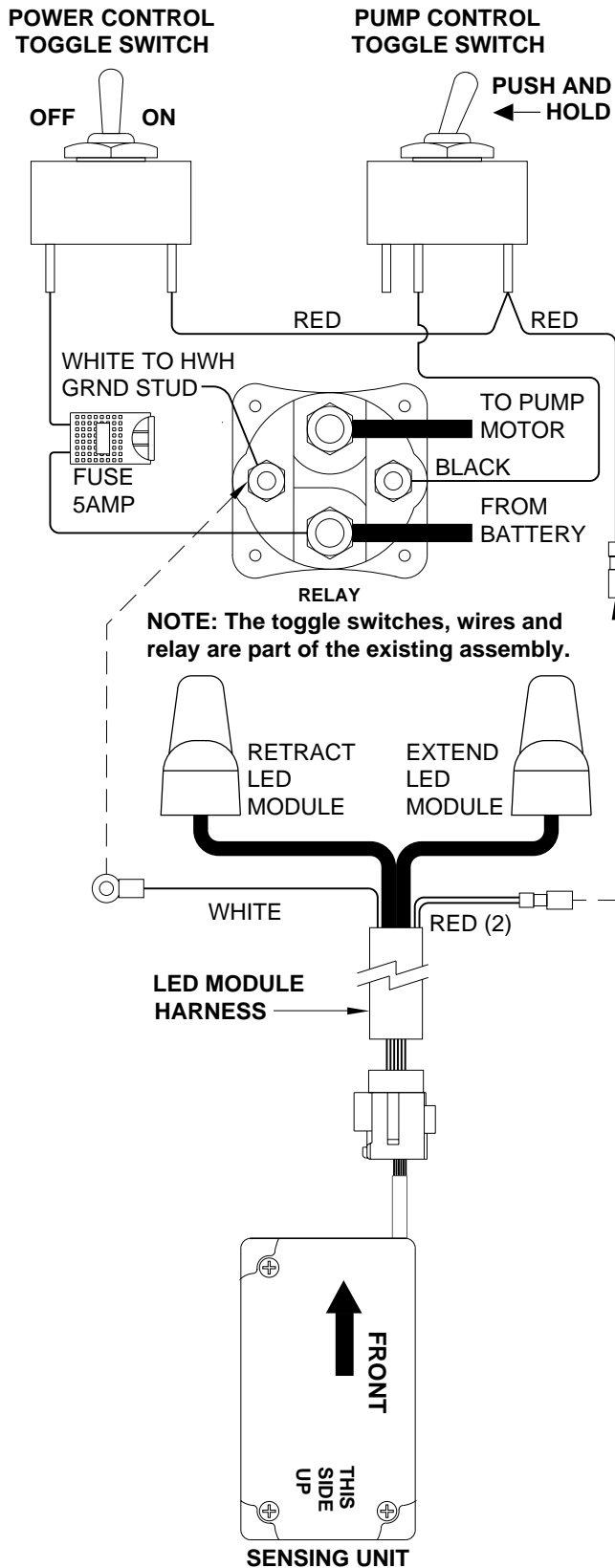

2. LED MODULES

Place the (4) flat washers then (4) lock washers and thread (just enough to hold the nuts to the screws) the (4) nuts one each to each of the screws protruding from the (2) LED modules. Slide the two screws of each module between the sets of fingers (indicated below). The "EXTEND" module (8 LED towers) should go to the reservoir side. The "RETRACT" (4 LED towers) should go to the motor side. Tighten the nuts sandwiching the fingers between the washer and the module. To avoid damaging the module **DO NOT** over tighten the nuts.

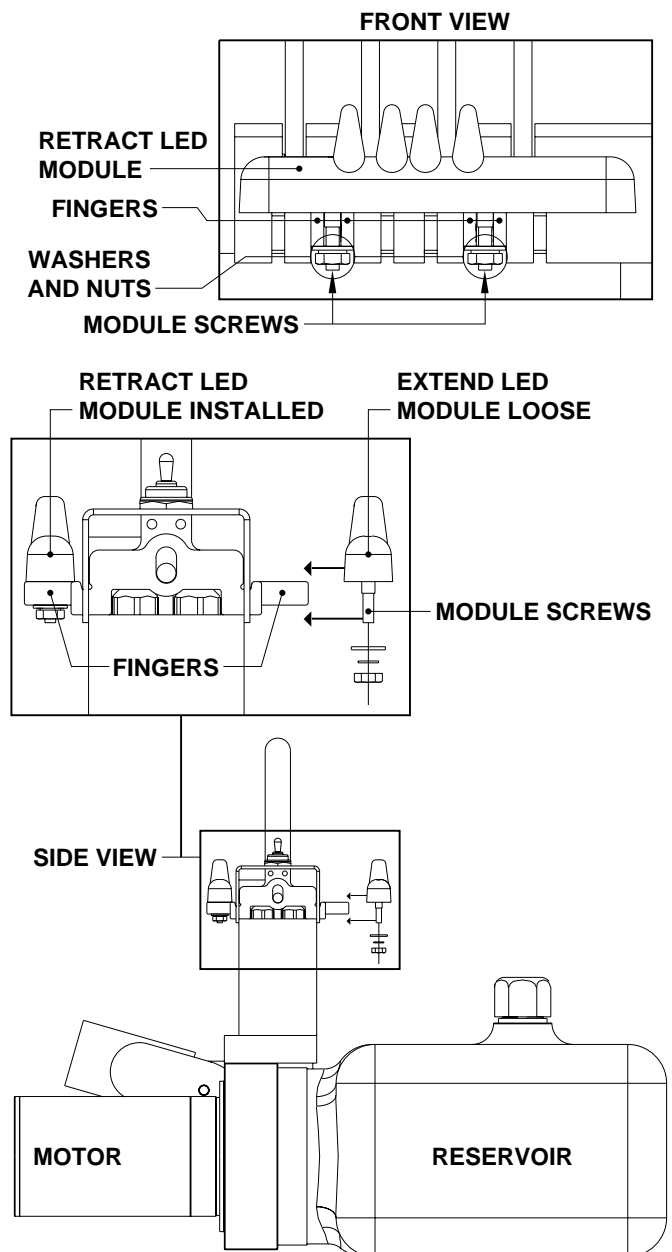

INSTRUCTION SHEET

LEVEZE® LIGHT PACKAGE INSTALLATION/ADJUSTMENT

INSTALLATION

3. SENSING UNIT

Using the (3) screws and (3) springs provided mount the sensing unit either below or above a ridged, fixed, horizontal surface (within the length of the module harness) as shown below. To prevent binding try to keep the screws straight up and down when starting. Tighten the screws until the springs are compressed to about 1/2 their original length.

BELOW SURFACE INSTALLATION

When mounting the sensing unit below a surface the LED side of the unit should be visible.

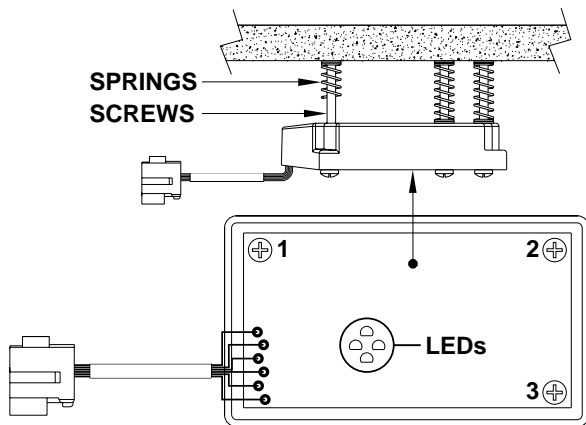

ABOVE SURFACE INSTALLATION

When mounting the sensing unit above a surface the "THIS SIDE UP" side of the unit should be visible.

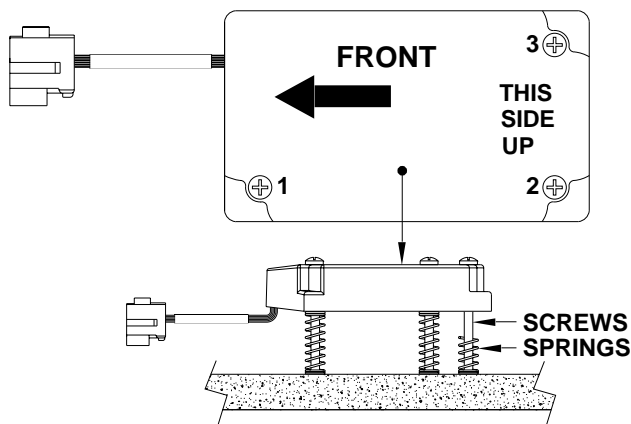

SENSING UNIT TOLERANCE

The sensing unit has an accuracy tolerance of ± 5.4 inches front to rear and ± 1 inch side to side on a 36 foot vehicle. Typical leveling results will be better.

SENSING UNIT ADJUSTMENT

Level the vehicle by placing a bubble level upon whichever surface within the trailer that is to be level.

With the trailer level according to the bubble level, if there are no yellow lights lit on either LED module or the sensing unit, the sensing unit is properly adjusted. If there are yellow LEVEL lights lit on either LED module or the sensing unit, manual adjustments to the sensing unit are needed.

Because of programming, the sensing unit LEDs may not correspond exactly to the EXTEND and RETRACT LED modules. The yellow LEDs of the EXTEND and RETRACT LED modules should be used to adjust the sensing unit.

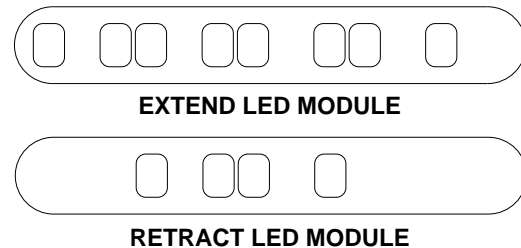

No more than two module LEDs should ever be lit at one time. The objective is to have no LEDs lit on either LED module when the vehicle is level.

To the left, both mounting views of the sensing unit (above and below surface) are shown. Each of the three screws has a number assigned to it. Use these screws to turn out the module LEDs. **Screw 2 should only be turned if screws 1 or 3 become too tight or too loose.**

If the LF and RF LEDs of the EXTEND LED MODULE are on,
BELOW SURFACE: Screw "1" should be tightened.
ABOVE SURFACE: Screw "1" should be loosened.

If the LR and RR LEDs of the RETRACT LED MODULE are on,
BELOW SURFACE: Screw "1" should be loosened.
ABOVE SURFACE: Screw "1" should be tightened.

If the RF and RR LEDs of the EXTEND LED MODULE are on,
BELOW SURFACE: Screw "3" should be tightened.
ABOVE SURFACE: Screw "3" should be loosened.

If the LR and LF LEDs of the RETRACT LED MODULE are on,
BELOW SURFACE: Screw "3" should be loosened.
ABOVE SURFACE: Screw "3" should be tightened.

Screw "2" should only be loosened or tightened if screws "1" or "3" become restricted by a fully compressed spring or loosened to the extent that all 3 screws are not threaded securely into the mounting surface.

IMPORTANT: BUMP THE SENSING UNIT TO SEE THAT IT IS SETTLED TIGHT AGAINST ALL THREE SCREW HEADS AND STILL INDICATES THAT THE UNIT IS LEVEL.