

XS Series Subwoofer Installation Instructions

Important Safety Information

WARNING

Failure to follow these warnings and cautions could result in personal injury, damage to the vehicle or vessel, or poor product performance.

See the *Important Safety and Product Information* guide in the product box for product warnings and other important information.

This device must be installed according to these instructions.

Disconnect the vehicle's or vessel's power supply before beginning to install this product.

CAUTION

Continuous exposure to sound pressure levels over 100 dBA may cause permanent hearing loss. The volume is typically too loud if you cannot hear people speaking around you. Limit the amount of time you listen at high volume. If you experience ringing in your ears or muffled speech, stop listening and have your hearing checked.

Always wear safety goggles, ear protection, and a dust mask when drilling, cutting, or sanding.

NOTICE

When drilling or cutting, always check what is on the opposite side of the surface.

It is strongly recommended that you have your audio system installed by a professional installer to ensure optimum performance.

You must read all installation instructions before beginning the installation.

After installing the subwoofer, you should run the subwoofer at low to medium volumes for the first few hours of use. This helps to improve the overall sound by gradually loosening up the moving components of the subwoofer, such as the cone, spider, and surround

What's In the Box

- 1 subwoofer
- 6 Phillips stainless steel, 4.8 mm x 50 mm (10 gauge x 2 in.) mounting screws
- Mounting template
- Grilles

Tools Needed

- Electric drill
- Drill bit (size varies based on surface material)
- Phillips screwdriver
- Wire strippers
- Crimping tool
- Electrical tape
- Appropriate saw or utility knife to cut surface material
- Marine sealant (optional)
- Suitable gauge speaker wire for the length required

NOTE: For customized installations, additional tools and materials may be needed.

Mounting Considerations

Selecting the correct mounting location is critical to optimize the performance of the audio system. This FUSION® subwoofer is designed to perform in the widest possible range of mounting

locations, but the more you plan the installation, the better the subwoofer sound will be.

- The audio system must be turned off before making any connections. Failure to do so could result in permanent damage to the audio system.
- You should protect all terminals and connections from grounding and from each other. Failure to do so could result in permanent damage to the audio system and voids the product warranty.
- You should protect the wires from sharp objects and always use rubber grommets when wiring through panels.
- The mounting location must avoid potential obstacles, such as fuel and hydraulic lines and wiring.
- The mounting location must provide sufficient clearance for the mounting depth of the subwoofer as specified in the side view drawings and the specifications.
- When possible, the area behind each subwoofer should be enclosed.
- To avoid interference with a magnetic compass, the subwoofer should not be installed closer to a compass than the compass-safe distance value listed in the product specifications.
- You should select a flat mounting surface for the best seal.
- For better bass performance, the subwoofer should be mounted in an area that provides just enough room behind the subwoofer. Too small an area restricts bass, and too large an area compromises bass performance. Refer to the specifications for optimum volume recommendations.
- When a subwoofer is not exposed to the outside environment, a better bass performance can be achieved using an enclosure that has a ported design. The Small parameters are provided in the specifications to assist with enclosure and port design.
- If you intend to mount the subwoofer outside the boat, follow these considerations.
 - When mounted correctly, the subwoofer is rated IP65 for protection in the marine environment from the front of the subwoofer. Water exposure and damage to the rear of the subwoofer voids the warranty.
 - The subwoofer must be mounted in a location well above the waterline, where it is not submerged.
 - The subwoofer must be mounted in a location where it cannot be damaged by docks, pilings, or other pieces of equipment.
 - The subwoofer should be mounted in a sealed enclosure, especially if it is exposed to wash down. A port or vent may allow water to collect in the enclosure and damage the subwoofer.

Mounting the Subwoofer

Before mounting the subwoofer, you must choose a location following the mounting considerations above.

Before cutting the mounting surface, you should verify that there is enough clearance for the speaker behind the surface. Refer to the specifications for clearance information.

NOTICE

Do not apply grease or lubricant to the screws when fastening the subwoofer to the mounting surface. Grease or other lubricants can cause damage to the subwoofer housing.

- 1 Route the wires from the source to the mounting location, away from sources of electrical interference.
- 2 Trim the template and make sure it fits in the selected location.
- 3 Orient the template so the FUSION logo is level in the selected location.

- 4 Secure the template to the selected location.
- 5 Using a rotary tool or jigsaw, cut the mounting surface along the inside of the line on the template.
- 6 Place the subwoofer in the cutout to test the fit.
- 7 If necessary, use a file and sandpaper to refine the size of the cutout.
- 8 After the subwoofer fits correctly in the cutout, ensure the mounting holes on the subwoofer line up with the pilot holes on the template.
- 9 If the mounting holes on the subwoofer do not line up, mark the new hole locations.
- 10 Using an appropriately sized drill bit for the mounting surface and screw type, drill the holes.
- 11 Remove the template from the mounting surface.
- 12 Connect the subwoofer wires ① while observing polarity ([Subwoofer Wiring, page 3](#)).

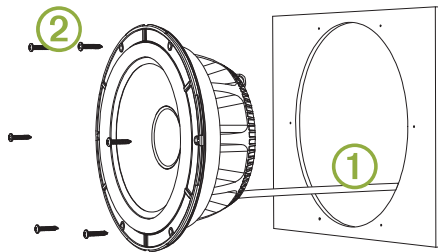

- 13 If necessary, connect the LED wires to the Sports model subwoofer ([LED Wiring, page 3](#)).
- 14 Place the subwoofer in the cutout.
- 15 Secure the subwoofer to the mounting surface using the included screws ②.

NOTE: Do not over tighten the screws, especially if the mounting surface is not flat.
- 16 With the subwoofer mounted, hold the grille with the FUSION logo at the bottom, or at the 6 o'clock position.
- 17 Press on the grille to snap it into place.

Subwoofer Wiring

When connecting the subwoofer to your amplifier or source, observe the following considerations.

- Speaker wire is not included with the subwoofer. You should use 20 AWG (0.52 mm²) speaker wire to connect the subwoofer to the amplifier or source.
- The leads on the subwoofer are terminated using male spade connectors. You should use female spade connectors (not included) to connect the speaker wire to the speaker leads for the best connection.
- The subwoofer features a dual 2 Ohm voice coil that can be configured for 2.1 operation (two speakers and one subwoofer) when connected to a FUSION stereo with DSP capability ([Configuring the Subwoofer for 2.1 Operation, page 4](#)).
- You can use the following table to identify the polarity of the leads on the speaker.

White	Positive (+)
Gray with a black stripe	Negative (-)

NOTE: Gray and white with a black stripe wires are connected to jumper terminals on the back of the subwoofer. These wires must remain connected to the jumper terminals for normal use (4 Ohm) and should be disconnected only when configuring the speaker for 2.1 operation.

LED Wiring

Connecting the LED Wires

You can control the color of the LEDs by connecting the LED color wires to ground. You can splice the ground wire to multiple LED wires to customize the LED color.

NOTE: This feature is available only on the sports model.

NOTE: Instead of connecting the LED wires for one dedicated color, you can install a remote control to turn the LEDs on and off, change the color, and create lighting effects.

The black wire on the LED cable is terminated with a 4 mm female bullet connector, and the color wires are terminated with 4 mm male bullet connectors. You can connect these to 4 mm bullet connectors on your wires (not included), or remove the bullet connectors to connect to the bare wires instead.

- 1 Connect a positive wire to the black wire on the LED cable.
- 2 Connect a ground wire to the wire on the LED cable

according to the preferred LED color.

LED Color	LED Wire Color
Red	Red
Green	Green
Blue	Blue
Yellow	Red and green
Magenta	Red and blue
Cyan	Blue and green
White	Red, green, and blue

- 3 Route the positive and negative wires, and connect them to a power source ([Connecting the LED Wires to Power, page 3](#)).

Connecting the LED Wires to Power

NOTE: This feature is available on only the sports model.

You must connect all 12 Vdc wiring to the LEDs to a 3 A fuse at the power-source end of the cable. You should connect the positive (+) power wire to a 12 Vdc power source through an isolator switch or circuit breaker to turn the LEDs on and off. You can use the same isolator or circuit breaker controlling the power supply to your stereo, which allows you to turn the LEDs and the stereo on and off at the same time.

You should use 22 AWG (0.33 mm²) or thicker wire to connect the LEDs to the battery.

- 1 Route the positive power (+) and negative ground (-) wires from the LED-wire connections to the battery.
- 2 Connect the negative wire to the negative (-) battery terminal.
- 3 Connect the positive wire to the positive (+) terminal through a 3 A fuse and isolator switch or circuit breaker.

Subwoofer Sound Optimization

While installing the subwoofer, you can ensure the sound from the subwoofer is optimized by running the subwoofer out of phase. You can switch the positive and negative wires on the amplifier or source to run them out of phase.

Running the subwoofer out of phase from the speakers allows you to hear if the perception of bass is more from the location of the subwoofer or from the speakers. If running the subwoofer out of phase gives a better perception that the bass is from the speakers' location, then out-of-phase wiring is correct for your system.

You can run the subwoofer out of phase by temporarily switching the positive and negative connections from the subwoofer at the amplifier or source. Depending on the outcome of the test, you can then switch the connections back if necessary.

Configuring the Subwoofer for 2.1 Operation

The subwoofer features dual 2 Ohm voice coils and is pre-configured for 4 Ohm operation. You can change the configuration of the subwoofer for 2.1 operation (two speakers and one subwoofer) when connected to a FUSION stereo with DSP capability, such as an Apollo™ RA770.

- 1 Disconnect the gray wire and the white with a black stripe wire from the jumper terminals on the back of the subwoofer.
- 2 Connect the wires from the subwoofer to the stereo using the following table as a reference.

Subwoofer wire	Stereo wire
White	Zone 2 right positive (+)
White with a black stripe	Zone 2 right negative (-)
Gray	Zone 2 left positive (+)
Gray with a black stripe	Zone 2 left negative (-)

- 3 Turn on the connected stereo.
- 4 Launch the FUSION-Link™ app, and select the 2.1 option for the connected stereo.

The subwoofer operates in 2.1 mode, with the volume control tied to zone 1 on the stereo. The zone 2 volume control and the zone 2 line out connectors are disabled.

Additional Information

True-Marine™ Products

True-Marine products are subjected to rigorous environmental testing under harsh marine conditions to surpass industry guidelines for marine products.

Any product that bears the True-Marine stamp of assurance has been designed for simplicity of use and combines advanced marine technologies to deliver an industry leading entertainment experience. All True-Marine products are supported by the FUSION 3-year worldwide limited consumer warranty.

Registering Your XS Series

Help us better support you by completing our online registration today.

- Go to website.
- Keep the original sales receipt, or a photocopy, in a safe place.

Cleaning the Subwoofer

NOTICE

Do not use harsh or solvent-based cleaners on the subwoofer. Using such cleaners may damage the product and void the warranty.

When mounted correctly, this subwoofer is rated IP65 for protection in the harsh marine environment from the front of the subwoofer. The subwoofer is not designed to withstand high pressure water spray, which may occur when you wash down your vessel. Failure to carefully spray-clean the vessel may damage the product and void the warranty.

- 1 Clean all salt water and salt residue from the grille with a damp cloth soaked in fresh water.
- 2 Use a mild detergent to remove a heavy buildup of salt or stains.

Troubleshooting

Before you contact your FUSION dealer or service center, you should perform a few simple troubleshooting steps to help diagnose the problem.

If the FUSION subwoofer has been installed by a professional installation company, you should contact the company so the technicians can assess the problem and advise you about possible solutions.

There is no sound coming from the subwoofer

- Verify that all connections are connected correctly to the proper terminals.

The system lacks bass

- Verify that the subwoofer is attached firmly to the mounting surface.

The audio is distorted

- Verify that the panels surrounding the subwoofer on the vessel are not rattling.
- Verify that the amplifier is connected to the subwoofer terminals correctly.
- If the subwoofer is connected to an amplifier, verify that the input level of the amplifier is matched to the output level of the stereo.

For more information, see the manual for the amplifier.

The LED lights will not turn on

- Verify that all wiring connections are correct and tight.

The LEDs pulse with the bass notes of the music

- Install a FUSION LED voltage regulator (SG-VREGLED).

Specifications

Peak power (Watts)	600 W
RMS power (Watts)	120 W
Efficiency (1 W/1 m)	87 dB
Frequency response	From 30 Hz to 2000 Hz
Nominal impedance	4 ohm
Recommended amplifier power (RMS)	40 to 300 W per channel
Min. mounting depth (clearance)	113 mm (4 ⁷ / ₁₆ in.)
Mounting diameter (clearance)	223 mm (8 ³ / ₄ in.)
Optimum enclosure volume recommendation*	40 L
LED color options (sports model only)	RGB
LED supply voltage (Sports model only)	From 10.8 to 16 Vdc
LED load current at 14.4 Vdc (Sports model only)	150 mA
Operating temperature range	From 0 to 50°C (from 32 to 122°F)
Storage temperature range	From -20 to 70°C (from -4 to 158°F)
Cone/surround material	Polypropylene cone, rubber surround
Water and dust rating	IEC 60529 IP65 (Protected against dust and water ingress)

*Sealed enclosure, fully filled with absorption material.

NOTE: This speaker is not intended to be installed in a vented or ported enclosure when exposed to the outside environment.

Speaker Dimensions

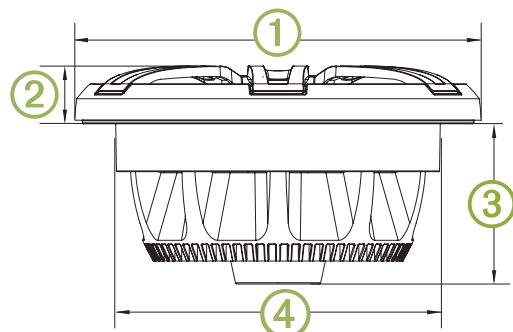

①	274 mm (10 ¹³ / ₁₆ in.)
②	Classic grille: 32 mm (1 ¹ / ₄ in.) Sports grille: 37 mm (1 ⁷ / ₁₆ in.)
③	110 mm (4 ⁵ / ₁₆ in.)
④	221 mm (8 ¹¹ / ₁₆ in.)

A Sports model subwoofer is shown, but the dimensions are the same for the Classic model unless noted.

Subwoofer Compass-Safe Distance

All speakers and subwoofers contain magnets which are likely to cause interference with instruments on your boat. The size of the magnet used in the subwoofer affects how much interference the subwoofer may cause.

Interference can cause deviations and variations in the readings of sensitive navigational equipment, such as magnetic compasses. These deviations can cause inaccuracies or offsets in the readings, but will not harm the equipment. To alleviate the deviations, adjust the compass for the deviation following the manufacturer's instructions or move the subwoofer away from the navigational equipment. After moving a source of interference, you may need to recalibrate the compass.

If you are navigating solely by a magnetic compass, use extreme caution to place the speaker far enough away from the compass to avoid causing deviations in the readings.

To avoid deviations to navigational equipment, position the subwoofer so it is separated from the navigational equipment by at least the distance listed in the table below.

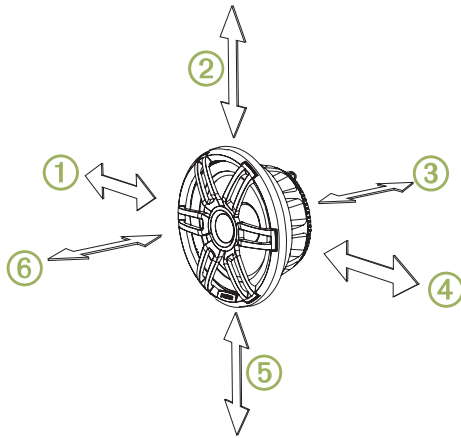

Direction from Subwoofer	10" Subwoofer
①	280 cm (9 ft. 2 in.)
②	280 cm (9 ft. 2 in.)
③	370 cm (12 ft. 2 in.)
④	280 cm (9 ft. 2 in.)
⑤	295 cm (9 ft. 8 in.)
⑥	350 cm (11 ft. 6 in.)

Thiele Small Parameters

You can use the Thiele Small (T/S) parameters when designing a custom enclosure for your subwoofer.

NOTE: Thiele/Small parameters may vary between samples, based on the environment and how much the speaker has been used. These values are intended as a guide to help with enclosure design.

Electrical Q factor (Q_{es})	1.20
Mechanical Q factor (Q_{ms})	5.80
Total Q factor (Q_{ts})	0.99
Resonance frequency (F_s)	41 Hz
Equivalent air load (V_{as})	40 L