

FURRION CHILL™

AIR DISTRIBUTION BOX WITH MANUAL CONTROL

FACT11MA

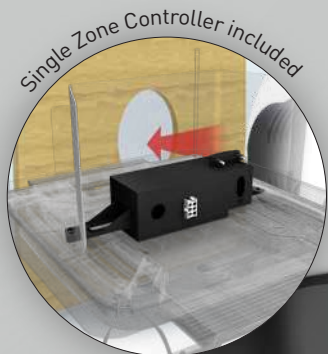

FACT11MA-BL



FACT11MA-PS



2 WAY
AIR FLOW



3 FAN
SPEEDS



DETACHABLE
FILTER



EASY
INSTALLATION



TEMPERATURE
CONTROL



CAN BE USED FOR
DUCTED / NON-DUCTED

- Compatible with all size of rooftop units
- Maximize air flow louver to two outlets
- Compatible with both ducted and non-ducted RVs

- Detachable filters for easy cleaning
- Stylish and slim design
- Available in black and white options



FACT11MA | AIR DISTRIBUTION BOX WITH MANUAL CONTROL

Air Distribution Box

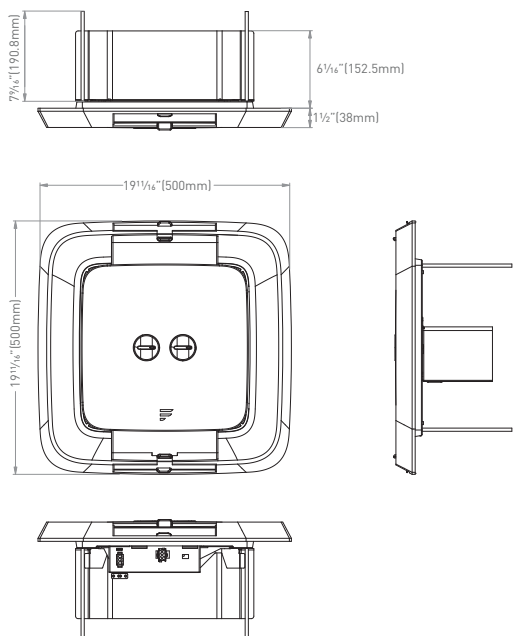

Single Zone Controller

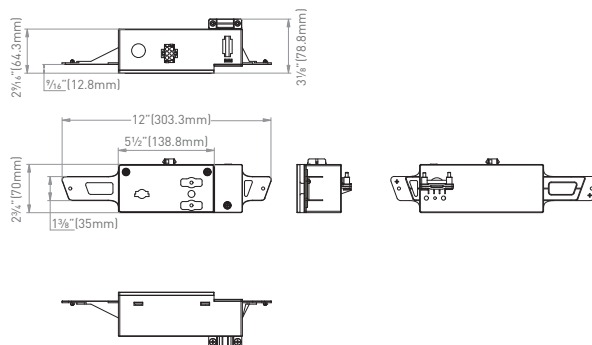

Specifications

Air Distribution Box	
Mechanical Control	8 positions
Two Way Air Outlet	✓
Indoor Sound Pressure Level	60dB
Controller	
Input Power	AC 115V
Frequency	60Hz
Compressor & Condenser Fan	AC 115V/20A
3 Evaporator Fan Motor Relay	AC 115V/5A
Temperature Range	18°C to 30°C/86°F to 86°F

Packaging Information

Air Distribution Box	
Packaging Type	Master Carton Box
Quantity Per Box (pcs)	1
Individual Packaging Dimensions (W x H x D)	20 7/16" x 20 1/2" x 5 3/8" (530 x 520 x 135mm)
Individual Packaging Gross Weight (lbs/kg)	8.6 / 3.9
Individual Packaging Net Weight (lbs/kg)	6.7 / 3
Single Zone Controller	
Packaging Type	Master Carton Box
Quantity Per Box (pcs)	1
Individual Packaging Dimensions (W x H x D)	25" x 12 7/16" x 13 7/16" (635 x 315 x 340mm)
Individual Packaging Gross Weight (kg/lbs)	15 / 33.1
Individual Packaging Net Weight (kg/lbs)	14 / 30.9

Container Load Information

Air Distribution Box	
20' Container Load (pcs)	836
40' Container Load (pcs)	1704
40'HQ Container Load (pcs)	1955
Single Zone Controller	
40'HQ Container Load (pcs)	37240

* Note: "✓"=Equipped