

FURRION CHILL™

14.5K ROOFTOP AIR CONDITIONER

FACR14SA

FACR14SA-BL



FACR14SA-PS



ULTRA QUIET



EASY INSTALL



HIGH ENERGY EFFICIENCY



AERODYNAMIC DESIGN

MID

PROFILE



HIGH COOLING CAPACITY



UV RESISTANT



LIGHTWEIGHT

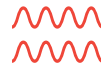

VIBRATIONSMART™



CLIMATESMART™

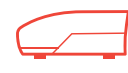

AVAILABLE IN
BLACK OR WHITE

- Advanced cooling performance
- Fit for manual and electronic air distribution box
- Dual fans run more efficiently and reduce operating noise
- Cleanable and replaceable air filter

- Available in stylish black and white options
- Fit for ducted or non-ducted cooling systems
- Aerodynamic rooftop design reduces wind resistance
- UV resistant cover, base and rear grill



FACR14SA | 14.5K ROOFTOP AIR CONDITIONER

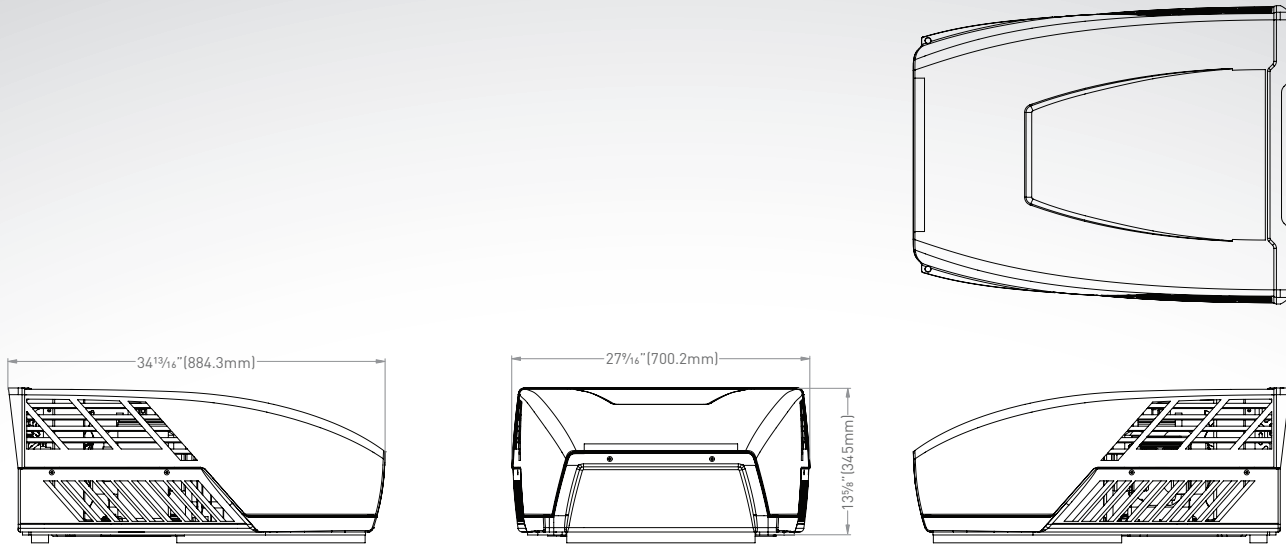

Specifications

Performance

Capacity	3450W
EER	2.13
Set Temperature Range	60°F to 86°F/16°C to 30°C
Outdoor Sound Pressure Level	80dB
IP class	IP24
Refrigerant	R410A

Electrical

Volts/Frequency/Phase	115V/60Hz/1Ph
Power [Cooling]	1620Watts
Amps [Cooling]	14.6

Features

Eco-friendly Refrigerant	✓
Rubber Damper	✓
Dual Fan Motors	✓
Thermo-insulated Heat Exchanger Enclosure	✓
3 Fan Speeds (High/Med/Low)	✓
Overload Protection	✓

Packaging Information

Packaging Type	Master Carton Box
Quantity Per Box (pcs)	1
Individual Packaging Dimensions (W x H x D)	35 1/16" x 28 7/16" x 15 1/2" [906 x 722 x 393mm]
Individual Packaging Gross Weight (lbs/kg)	88.2 / 40
Individual Packaging Net Weight (lbs/kg)	79.4 / 36

Container Load Information

20' Container Load (pcs)	120
40' Container Load (pcs)	252
40'HQ Container Load (pcs)	252