



**RECORD THIS INFORMATION FOR FUTURE REFERENCE:**

Model Number \_\_\_\_\_

Serial Number \_\_\_\_\_

ADB Model Number \_\_\_\_\_

ADB Serial Number \_\_\_\_\_

Date Purchased \_\_\_\_\_

# INSTALLATIONS INSTRUCTIONS

Roof Top Unit Used With 3314850.000 Air Distribution Box				
Description	Model	Board Built In OR Electronic Control Kit	Thermostat	Optional Indoor Temperature Sensor
<b>Air Conditioner</b>				
CCC 2 Controls	541815, 541816 641815, 641816	Board Built In	3314082.000 CCC2-Blk 3314082.011 CCC2-Wht	3311931.000-20' 3311931.012-40' 3311931.020-60'
	457915, 459516 459530, 540315 540316, 640310 640312, 640315 B57915, B59516 B57930	3312020.000		
CCC 2 Controls W/Electric Heat	641835	Board Built In		
LCD SZ Controls	541915 541916 641915 641916	Board Built In	3313192.000 C/F-Wht 3313192.019 C/F-Blk	N/A
	457915, 459516 540315, 540316 B57915, B59516	3313189.000 C/F-Wht 3313189.015 C/F-Blk 3313189.049 C/F/HS-Wht 3313189.056 C/F/HS-Blk	Thermostat Included With Electronic Control Kit	
	640310, 640312 640315, 459530 B59530	3313189.000 C/F-Wht 3313189.015 C/F-Blk		
LCD SZ Controls W/Electric Heat	641935	Board Built In	3313194.000 C/F/HS-Wht 3313194.015 C/F/HS-Blk	
	B57935U, B57935Y B59536U, B59536Y			
<b>Heat Pump</b>				
CCC 2 Controls	551816 651815 651816	Board Built In	3314082.000 CCC2-Blk 3314082.011 CCC2-Wht	3311931.000-20' 3311931.012-40' 3311931.020-60'
	459186, B59186	3312020.000		
LCD SZ Controls	551916 651916	Board Built In	3313193.000 C/F/HP-Wht 3313193.017 C/F/HP-Blk	N/A
	459196 B59196	3313189.064 C/F/HP-Wht 3313189.072 C/F/HP-Blk	Thermostat Included With Electronic Control Kit	

This Unit is designed for OEM installation.



**Read these instructions carefully. These instructions MUST stay with this product.**

# INTRODUCTION

This air conditioner/heat pump (hereinafter referred to as “unit” or “product”) is designed and intended for installation on the roof of a Recreational Vehicle (hereinafter referred to as RV) during the time it is manufactured.

Read these instructions and highlight the appropriate steps for your particular procedure before starting the installation.

This unit can be installed by one person with brief help from additional personnel. Use these instructions to ensure a properly installed, and properly functioning product.

Dometic Corporation reserves the right to modify appearances and specifications without notice.

# TABLE OF CONTENTS

INTRODUCTION .....	2
DOCUMENT SYMBOLS.....	2
IMPORTANT SAFETY INSTRUCTIONS .....	3
A. Recognize Safety Information .....	3
B. Understand Signal Words.....	3
C. Supplemental Directives.....	3
D. General Safety Messages .....	3
SPECIFICATIONS .....	4
A. Table - Unit Data.....	4
B. Roof Requirements.....	5
INSTALLATION INSTRUCTIONS .....	6
A. Choosing Proper Location For Unit.....	6
B. Roof Preparation .....	7
C. Wiring Requirements .....	8
D. Choosing Thermostat Location.....	9
E. Thermostat, Optional Indoor Temperature Sensor & Thermostat Communication Cable Installation .....	9
F. Placing Unit On Roof.....	10
G. Installation Preparation.....	11
H. 120 Vac Power Supply Connection .....	11
I. 120 Vac Power Supply Connection For 541X1XA, 551X16A, 6418XXH, & 65181XH Models. ....	12
J. Duct Divider Installation.....	14
K. LCD SZ System Low Voltage Wire Connections.....	14
L. CCC 2 System Low Voltage Wire Connections.....	15
M. (CCC 2 System Only) Configuration.....	16
N. Installing Unit.....	17
O. Installing ADB .....	18
P. (CCC 2 System Only) Reset & Checkout.....	19
Q. (CCC 2 System Only) Furnace/Aqua Temperature Differential Setting.....	20
GENERAL INFORMATION .....	21
A. Frost Formation On Cooling Coil.....	21
B. Heat Gain .....	21
C. Condensation .....	21
D. Air Distribution .....	21
WIRING DIAGRAMS .....	22
A. Simple RV Wiring Diagram.....	22
B. Unit Wiring Diagrams.....	23
C. Electronic Control Kit Wiring Diagrams .....	25

# DOCUMENT SYMBOLS

 Indicates additional information that is **NOT** related to physical injury.

 Indicates step-by-step instructions.

# IMPORTANT SAFETY INSTRUCTIONS

This manual has safety information and instructions to help users eliminate or reduce the risk of accidents and injuries.

## A. Recognize Safety Information



This is the safety alert symbol. It is used to alert you to potential physical injury hazards. Obey all safety messages that follow this symbol to avoid possible injury or death.

## B. Understand Signal Words

A signal word will identify safety messages and property damage messages, and will indicate the degree or level of hazard seriousness.

**WARNING** indicates a hazardous situation that, if **NOT** avoided, could result in death or serious injury.

**CAUTION** indicates a hazardous situation that, if **NOT** avoided, could result in minor or moderate injury.

**NOTICE** is used to address practices **NOT** related to physical injury.

## C. Supplemental Directives



Read and follow all safety information and instructions to avoid possible injury or death.

Read and understand these instructions before [installing / using / servicing / performing maintenance on] this product.

Incorrect [installation / operation / servicing / maintaining] of this product can lead to serious injury. Follow all instructions.

The installation **MUST** comply with all applicable local or national codes, including the latest edition of the following standards:

### U.S.A.

- ANSI/NFPA70, National Electrical Code (NEC)
- ANSI/NFPA 1192, Recreational Vehicles Code

### CANADA

- CSA C22.1, Parts I & II, Canadian Electrical Code
- CSA Z240 RV Series, Recreational Vehicles

## D. General Safety Messages



Failure to obey the following warnings could result in death or serious injury:

- This product **MUST** be [installed / serviced] by a qualified service technician.
- Do **NOT** modify this product in any way. Modification can be extremely hazardous.
- Do **NOT** add any devices or accessories to this product except those specifically authorized in writing by Dometic Corporation.

# SPECIFICATIONS

## A. Table - Unit Data

Model No.	Nominal Capacity (BTU HR) Cooling	Electrical Rating	Compressor Rated Load Amps	Compressor Locked Rotor Amps	Fan Motor Rated Load Amps	Fan Motor Locked Rotor Amps	Refrigerant R-410A (oz)	Minimum Wire Size*	AC Circuit Protection ***Installer Supplied	Minimum Generator Size** 1 Unit / 2 Units
457915.70X	13,500	120 Vac 60 Hz 1 ph	12.4	63.0	2.5	5.8	18.0	12 AWG Copper Up to 24'	20 Amp	3.5 kW / 5.0 kW
457915.71X	13,500		12.4	68.0	2.5	5.8	18.0		20 Amp	3.5 kW / 5.0 kW
B57915.71X	13,500		12.4	68.0	2.5	5.8	16.0		20 Amp	3.5 kW / 5.0 kW
B57935U71X	13,500		12.7	68.0	2.7	5.8	16.0		20 Amp	3.5 kW / 5.0 kW
B57935Y71X	13,500		12.7	68.0	2.7	5.8	16.0		20 Amp	3.5 kW / 5.0 kW
459186.70X	15,000		13.3	66.0	2.0	5.6	29.0		20 Amp	3.5 kW / 5.0 kW
459186.71X	15,000		13.3	70.0	2.0	5.6	29.0		20 Amp	3.5 kW / 5.0 kW
B59186.71X	15,000		13.3	70.0	2.0	5.6	29.0		20 Amp	3.5 kW / 5.0 kW
459196.70X	15,000		13.3	66.0	2.0	5.6	29.0		20 Amp	3.5 kW / 5.0 kW
459196.71X	15,000		13.3	70.0	2.0	5.6	29.0		20 Amp	3.5 kW / 5.0 kW
B59196.71X	15,000		13.3	70.0	2.0	5.6	29.0		20 Amp	3.5 kW / 5.0 kW
459516.70X	15,000		13.3	66.0	2.0	5.6	27.5		20 Amp	3.5 kW / 5.0 kW
459516.71X	15,000		13.3	70.0	2.0	5.6	27.5		20 Amp	3.5 kW / 5.0 kW
B59516.71X	15,000		13.3	70.0	2.0	5.6	18.3		20 Amp	3.5 kW / 5.0 kW
459530.70X	N/A		8.6	50.0	2.5	5.8	20.0		15 Amp	2.5 kW / 4.0 kW
B59530.71X	N/A		8.6	50.0	2.5	5.8	20.0		15 Amp	2.5 kW / 4.0 kW
B59536U71X	15,000		13.2	70.0	2.7	5.6	18.3		20 Amp	3.5 kW / 5.0 kW
B59536Y71X	15,000		13.2	70.0	2.7	5.6	18.3		20 Amp	3.5 kW / 5.0 kW
540315.70X	13,500		12.4	63.0	3.0	8.5	18.5		20 Amp	3.5 kW / 5.0 kW
540315.71X	13,500		12.4	68.0	3.0	8.5	18.5		20 Amp	3.5 kW / 5.0 kW
540316.70X	15,000		13.3	66.0	2.8	7.6	29.5		20 Amp	3.5 kW / 5.0 kW
540316.71X	15,000		13.3	70.0	2.8	7.6	29.5		20 Amp	3.5 kW / 5.0 kW
541815A70X	13,500		12.4	63.0	3.0	8.5	18.5		20 Amp	3.5 kW / 5.0 kW
541815A71X	13,500		12.4	68.0	3.0	8.5	18.5		20 Amp	3.5 kW / 5.0 kW
541816A70X	15,000		13.3	66.0	2.8	7.6	29.5		20 Amp	3.5 kW / 5.0 kW
541816A71X	15,000		13.3	70.0	2.8	7.6	29.5		20 Amp	3.5 kW / 5.0 kW
541915A70X	13,500		12.4	63.0	3.0	8.5	18.5		20 Amp	3.5 kW / 5.0 kW
541915A71X	13,500		12.4	68.0	3.0	8.5	18.5		20 Amp	3.5 kW / 5.0 kW
541916A70X	15,000		13.3	66.0	2.8	7.6	29.5		20 Amp	3.5 kW / 5.0 kW
541916A71X	15,000		13.3	70.0	2.8	7.6	29.5		20 Amp	3.5 kW / 5.0 kW
551816.70X	15,000		12.8	60.0	2.8	7.6	29.5		20 Amp	3.5 kW / 5.0 kW
551816.71X	15,000		12.8	70.0	2.8	7.6	29.5		20 Amp	3.5 kW / 5.0 kW
551816A70X	15,000		12.8	60.0	2.8	7.6	29.5		20 Amp	3.5 kW / 5.0 kW
551816A71X	15,000	12.8	70.0	2.8	7.6	29.5	20 Amp	3.5 kW / 5.0 kW		
551916A71X	15,000	12.8	70.0	2.8	7.6	29.5	20 Amp	3.5 kW / 5.0 kW		
640310C45X	N/A	8.8	5.6	2.6	8.5	20.5	15 Amp	2.5 kW / 4.0 kW		
640312.80X	11,000	11.5	53.0	2.6	8.5	20.0	20 Amp	3.5 kW / 5.0 kW		
640312.83X	11,000	12.5	63.0	2.6	8.5	18.0	20 Amp	3.5 kW / 5.0 kW		
640312C35X	11,000	10.5	53.0	3.5	10.0	19.0	20 Amp	3.5 kW / 5.0 kW		
640312C85X	11,000	11.5	53.0	2.6	8.5	20.0	20 Amp	3.5 kW / 5.0 kW		
640315.80X	13,500	12.6	63.0	2.6	8.5	18.0	20 Amp	3.5 kW / 5.0 kW		
640315.83X	13,500	12.5	63.0	2.6	8.5	19.0	20 Amp	3.5 kW / 5.0 kW		
640315.84X	13,500	12.5	63.0	3.5	8.5	19.0	20 Amp	3.5 kW / 5.0 kW		
640315C35X	13,500	12.5	61.0	3.5	10.0	17.5	20 Amp	3.5 kW / 5.0 kW		
640315C75X	13,500	12.7	52.0	2.6	8.5	14.5	20 Amp	3.5 kW / 5.0 kW		
640315C85X	13,500	12.6	63.0	2.6	8.5	18.0	20 Amp	3.5 kW / 5.0 kW		
641815.80X	13,500	12.6	63.0	2.6	8.5	19.0	20 Amp	3.5 kW / 5.0 kW		
641815C35X	13,500	12.5	61.0	3.5	10.0	17.5	20 Amp	3.5 kW / 5.0 kW		
64181C75X	13,500	12.7	52.0	2.6	8.5	14.5	20 Amp	3.5 kW / 5.0 kW		
64181C85X	13,500	12.6	63.0	2.6	8.5	19.0	20 Amp	3.5 kW / 5.0 kW		

# SPECIFICATIONS

Model No.	Nominal Capacity (BTU HR) Cooling	Electrical Rating	Compressor Rated Load Amps	Compressor Locked Rotor Amps	Fan Motor Rated Load Amps	Fan Motor Locked Rotor Amps	Refrigerant R-410A (oz)	Minimum Wire Size*	AC Circuit Protection ***Installer Supplied	Minimum Generator Size** 1 Unit / 2 Units
641815H75X	13,500	120 Vac 60 Hz 1 ph	12.7	52.0	2.6	8.5	14.5	12 AWG Copper Up to 24'	20 Amp	3.5 kW / 5.0 kW
641815H85X	13,500		12.6	63.0	2.6	8.5	19.0		20 Amp	3.5 kW / 5.0 kW
641816.80X	Hi Cap		13.4	63.0	2.6	8.5	23.0		20 Amp	3.5 kW / 5.0 kW
641816C35X	Hi Cap		12.3	61.0	3.3	8.5	23.0		20 Amp	3.5 kW / 5.0 kW
641816C75X	Hi Cap		12.9	52.0	2.6	8.5	21.5		20 Amp	3.5 kW / 5.0 kW
641816C85X	Hi Cap		13.4	63.0	2.6	8.5	23.0		20 Amp	3.5 kW / 5.0 kW
641816H75X	Hi Cap		12.9	52.0	2.6	8.5	21.5		20 Amp	3.5 kW / 5.0 kW
641816H85X	Hi Cap		13.4	63.0	2.6	8.5	23.0		20 Amp	3.5 kW / 5.0 kW
641835.80X	13,500		12.6	63.0	2.6	8.5	19.0		20 Amp	3.5 kW / 5.0 kW
641835C35X	13,500		12.5	61.0	3.5	10.0	17.5		20 Amp	3.5 kW / 5.0 kW
641835C75X	13,500		12.7	52.0	2.6	8.5	14.5		20 Amp	3.5 kW / 5.0 kW
641835C85X	13,500		12.6	63.0	2.6	8.5	19.0		20 Amp	3.5 kW / 5.0 kW
641835H75X	13,500		12.7	52.0	2.6	8.5	14.5		20 Amp	3.5 kW / 5.0 kW
641835H85X	13,500		12.6	63.0	2.6	8.5	19.0		20 Amp	3.5 kW / 5.0 kW
641915.80X	13,500		12.6	63.0	2.6	8.5	19.0		20 Amp	3.5 kW / 5.0 kW
641915C35X	13,500		12.5	61.0	3.5	10.0	17.5		20 Amp	3.5 kW / 5.0 kW
641915C75X	13,500		12.7	52.0	2.6	8.5	14.5		20 Amp	3.5 kW / 5.0 kW
641915C85X	13,500		12.6	63.0	2.6	8.5	19.0		20 Amp	3.5 kW / 5.0 kW
641916.80X	Hi Cap		13.4	63.0	2.6	8.5	23.0		20 Amp	3.5 kW / 5.0 kW
641916C35X	Hi Cap		12.3	61.0	3.3	8.5	23.0		20 Amp	3.5 kW / 5.0 kW
641916C75X	Hi Cap		12.9	52.0	2.6	8.5	21.5		20 Amp	3.5 kW / 5.0 kW
641916C85X	Hi Cap		13.4	63.0	2.6	8.5	23.0		20 Amp	3.5 kW / 5.0 kW
641935.80X	13,500		12.5	63.0	2.6	8.5	19.0		20 Amp	3.5 kW / 5.0 kW
641935C35X	13,500		12.5	61.0	3.5	10.0	17.5		20 Amp	3.5 kW / 5.0 kW
641935C75X	13,500		12.7	52.0	2.6	8.5	14.5		20 Amp	3.5 kW / 5.0 kW
641935C85X	13,500		12.5	63.0	2.6	8.5	19.0		20 Amp	3.5 kW / 5.0 kW
651815.80X	13,500		13.1	63.0	2.6	8.5	24.0		20 Amp	3.5 kW / 5.0 kW
651815C35X	13,500		12.5	61.0	3.5	10.0	25.0		20 Amp	3.5 kW / 5.0 kW
651815C75X	13,500		12.7	52.0	2.6	8.5	19.0		20 Amp	3.5 kW / 5.0 kW
651815C85X	13,500		13.1	63.0	2.6	8.5	24.0		20 Amp	3.5 kW / 5.0 kW
651815H75X	13,500		12.7	52.0	2.6	8.5	19.0		20 Amp	3.5 kW / 5.0 kW
651815H85X	13,500		13.1	63.0	2.6	8.5	24.0		20 Amp	3.5 kW / 5.0 kW
651816.80X	Hi Cap		13.4	63.0	2.6	8.5	27.0		20 Amp	3.5 kW / 5.0 kW
651816C35X	Hi Cap		12.3	61.0	3.3	8.5	24.0		20 Amp	3.5 kW / 5.0 kW
651816C75X	Hi Cap		13.0	52.0	2.6	8.5	23.0		20 Amp	3.5 kW / 5.0 kW
651816C85X	Hi Cap		13.4	63.0	2.6	8.5	27.0		20 Amp	3.5 kW / 5.0 kW
651816H75X	Hi Cap		13.0	52.0	2.6	8.5	23.0		20 Amp	3.5 kW / 5.0 kW
651816H85X	Hi Cap		13.4	63.0	2.6	8.5	27.0		20 Amp	3.5 kW / 5.0 kW
651916.80X	Hi Cap		13.4	63.0	2.6	8.5	27.0		20 Amp	3.5 kW / 5.0 kW
651916C35X	Hi Cap		12.3	61.0	3.3	8.5	24.0		20 Amp	3.5 kW / 5.0 kW
651916C75X	Hi Cap	13.0	52.0	2.6	8.5	23.0	20 Amp	3.5 kW / 5.0 kW		
651916C85X	Hi Cap	13.4	63.0	2.6	8.5	27.0	20 Amp	3.5 kW / 5.0 kW		

\* For wire length over 24 ft., consult the National Electrical Code for proper sizing.

\*\* Dometic Corporation gives **GENERAL** guidelines for generator requirements. These guidelines come from experiences people have had in actual applications. When sizing the generator, the total power usage of your RV must be considered. Keep in mind generators lose power at high altitudes and from lack of maintenance.

\*\*\* **CIRCUIT PROTECTION:** Time Delay Fuse or Circuit Breaker Required.

## B. Roof Requirements

- A 14-1/4" x 14-1/4" (±1/8") square opening (hereinafter referred to as "roof opening") is required for installing this unit. This opening is part of the return air system of the unit and **MUST** be finished in accordance with NFPA 1192.
- Roof construction with rafters/joists support frames on a minimum of 16 inch centers.
- Minimum of 2 inches and maximum of 4 inches distance between roof to ceiling of RV.

# INSTALLATION INSTRUCTIONS

## A. Choosing Proper Location For Unit

This unit is specifically designed for installation on the roof of an RV. When determining your cooling requirements, the following should be considered:

- Size of RV;
- Window area (increases heat gain);
- Amount of insulation in walls and roof;
- Geographical location where the RV will be used;
- Personal comfort level required.

1. For one unit installation: The unit should be mounted slightly forward of center (front to back) and centered from side to side.
2. For two unit installations: Install one unit 1/3 and one unit 2/3's from front of RV and centered from side to side.

It is preferred that the unit be installed on a relatively flat and level roof section measured with the RV parked on a level surface. See table below for maximum acceptable tilt.

Model Number	Max Tilt	Model Number	Max Tilt	Model Number	Max Tilt
457915	15°	B59530	15°	640310	8°
B57915		B59536U		640312	
B57935U		B59536Y		640315	
B57935Y		540315		641815	
459186		540316		641816	
B59186	541815	641835			
459196	541816	641915			
B59196	541915	641916			
459516	541916	641935			
B59516	551816	651815			
459530	551916	651816			
				651916	

3. After Location Has Been Selected:
  - a. Check for obstructions in the area where unit will be installed. See (FIG. 1), (FIG. 2), (FIG. 3), (FIG. 4), & (FIG. 5).

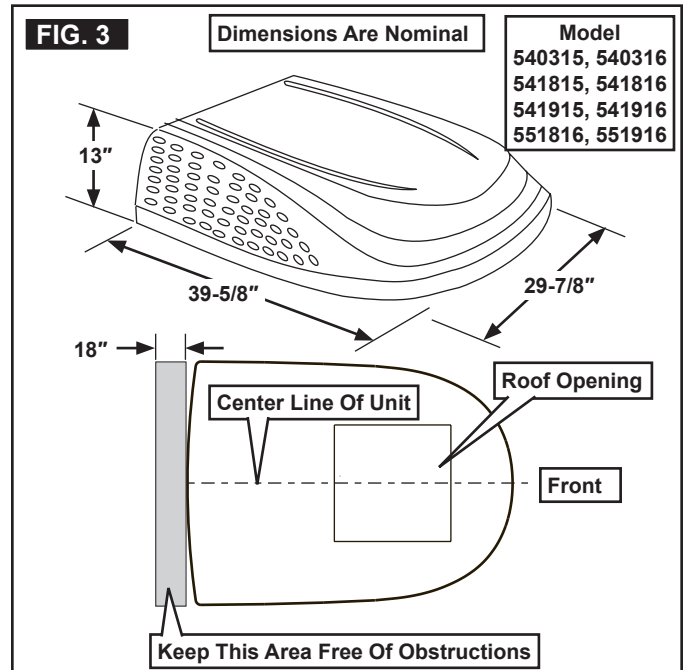
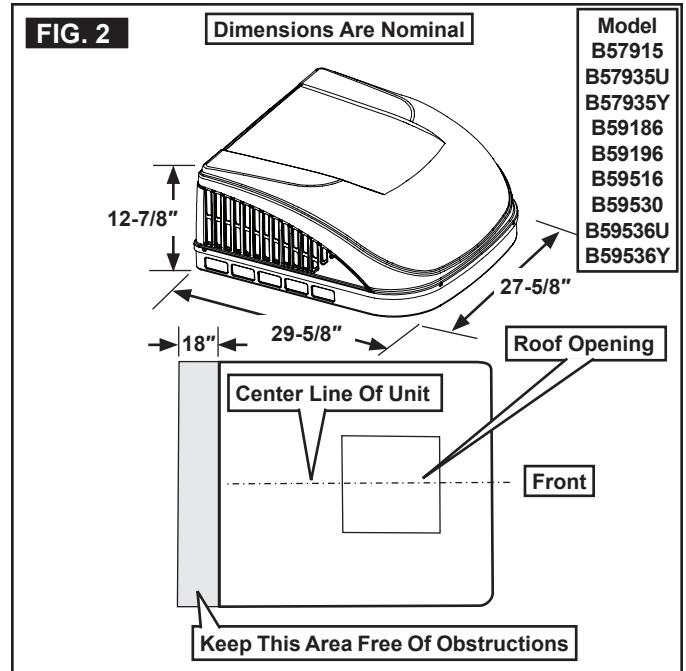
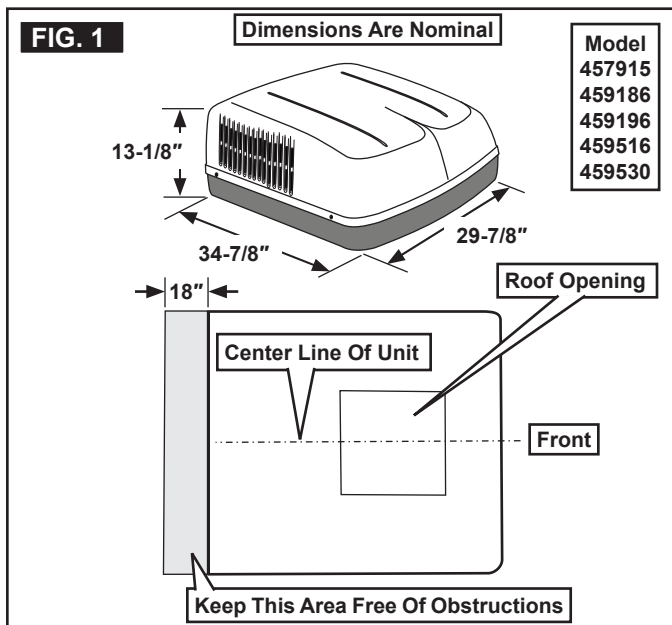

# INSTALLATION INSTRUCTIONS

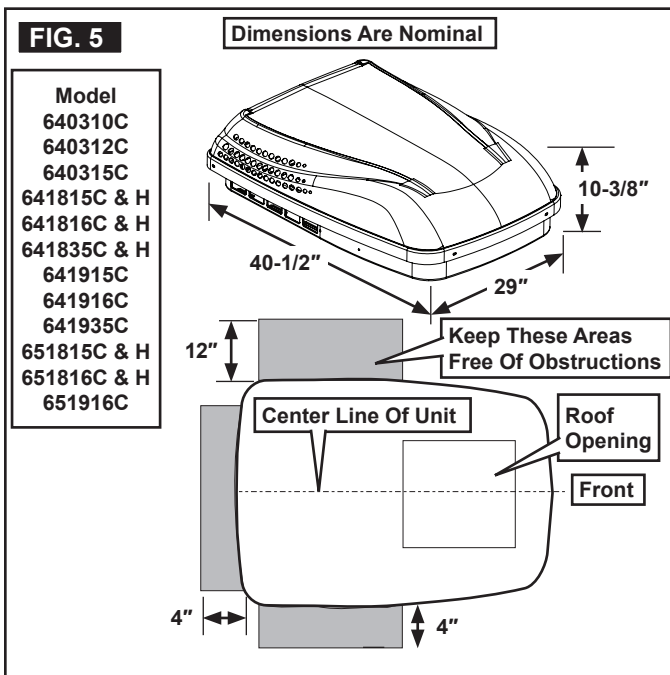
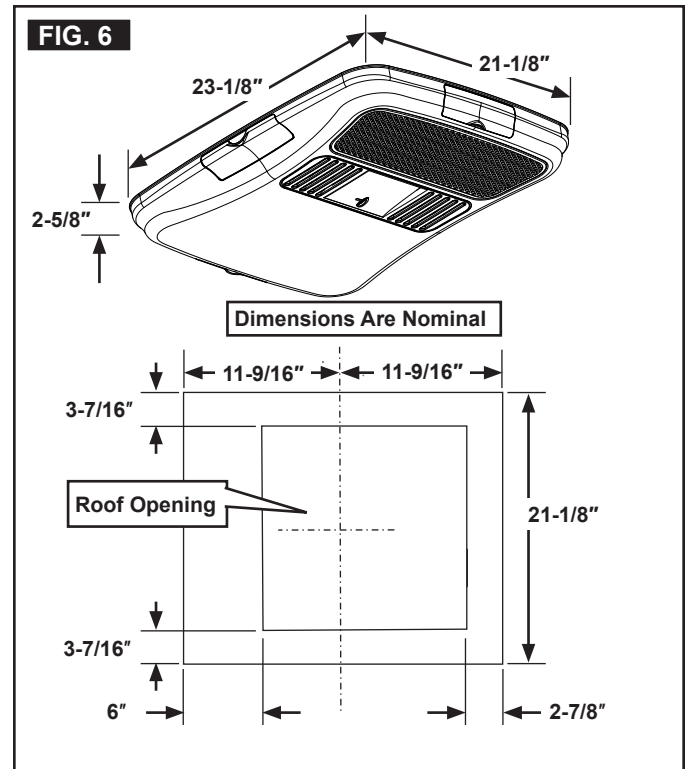
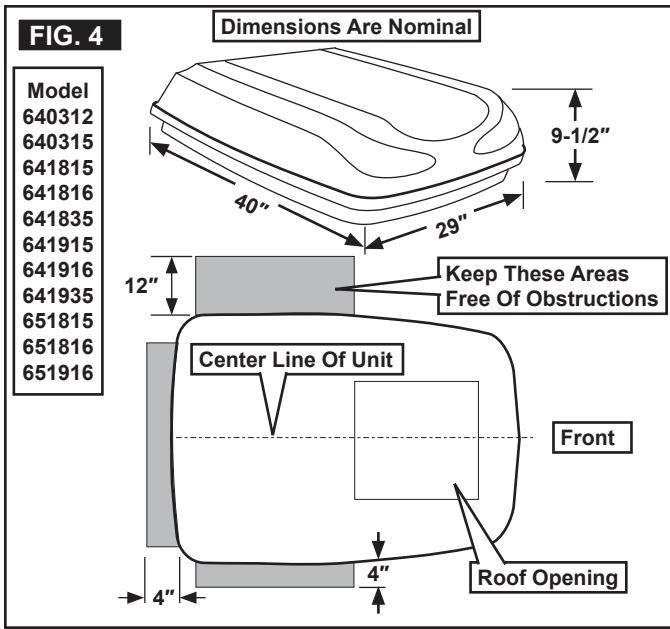

## B. Roof Preparation

- WARNING** FIRE OR ELECTRICAL SHOCK HAZARD. Make sure there are no obstacles (wires, pipes, etc.) inside RV's [roof / floor / walls]. Shut **OFF** gas supply, disconnect 120 Vac power from RV, and disconnect positive (+) 12 Vdc terminal from supply battery **BEFORE** drilling or cutting into RV. Failure to obey these warnings could result in death or serious injury.

Opening Requirements - Before preparing the ceiling opening, the type of system options **MUST** be decided upon. Read all of the following instructions before beginning the installation.

- Carefully mark and cut the required roof opening. See "B. Roof Requirements" on page (5).
- Using the roof opening as a guide, cut the matching hole in the ceiling.
- NOTICE** Maintain structural integrity. Otherwise damage to product and/or RV could occur.

**NOTICE** NEVER create a low spot on RV roof. Otherwise, water will pool and could cause a leak.

- NOTICE** Maintain structural integrity. Otherwise damage to product and/or RV could occur.

The roof must be designed to support 130 pounds when RV is in motion. Normally a 200 lb. static load design will meet this requirement.

- Check inside the RV for air distribution box (hereinafter referred to as "ADB") obstructions (i.e. door openings, room dividers, curtains, ceiling fixtures, etc.). See (FIG. 6).

# INSTALLATION INSTRUCTIONS

The opening created must be framed to provide adequate support and prevent air from being drawn from the roof cavity. Framing stock 3/4" or more in thickness must be used. Remember to provide an entrance hole for power supplies, indoor temperature sensor (if applicable), thermostat communication cable, and furnace wires (if applicable) at the front of the opening. See (FIG. 7).

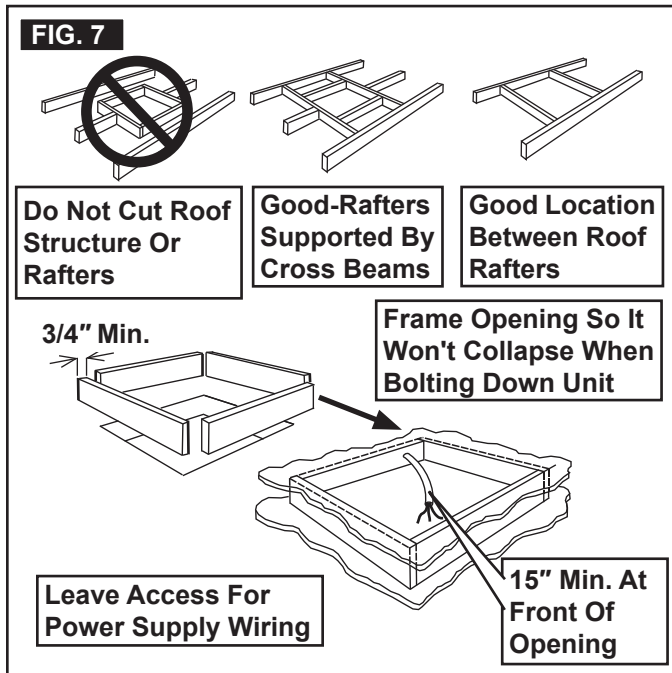

## C. Wiring Requirements

1. Route a copper, with ground, 120 Vac supply wire from the time delay fuse or circuit breaker box to the roof opening. Use a listed/certified non metallic - sheathed single strand cable. See "A. Table - Unit Data" on page (4).
  - a. This supply wire must be located in the front portion of the roof opening.
  - b. The power **MUST** be on an appropriately sized separate time delay fuse or circuit breaker. See "A. Table - Unit Data" on page (4).
  - c. Make sure that at least 15" of supply wire extends into the roof opening. This ensures an easy connection at the junction box.
  - d. Protect the wire where it passes into the opening with approved method.
2. Route a dedicated 12 Vdc supply wire (18-22) AWG) from the RV converter (filtered side) or battery to the roof opening.

**i** When a Comfort Control Center 2 (hereinafter referred to as CCC 2) thermostat is being installed with more than 2 zones, route a dedicated 12 Vdc supply wire (18-22 AWG) to zone 1 and zone 3 roof opening.

- a. This supply wire must be located in the front portion of the roof opening.
  - b. Make sure that at least 15" of supply wire extends into the roof opening.
3. Thermostat Communication Cable
    - a. CCC 2 Thermostat
      1. Route a 4 conductor communication cable from the roof opening to the thermostat mounting location using the shortest most direct route. Make sure that at least 15" of the wire extends into the roof opening and 6" extends from the wall at the thermostat mounting location. See "D. Choosing Thermostat Location" on page (9).

**i** When more than one unit is being installed (additional zones) with the CCC 2 thermostat, an additional 4 conductor communication cable **MUST** be routed to each additional unit roof opening. Make sure that at least 15" of the wire extends into the roof opening. See (FIG. 47).

- b. LCD SZ Thermostat
  1. Route a 3 conductor communication cable, 18 to 22 AWG, from the roof opening to the Liquid Crystal Display Single Zone (hereinafter referred to a LCD SZ) thermostat mounting location. Make sure that at least 15" of the wire extends into the roof opening and 6" extends from the wall at the thermostat mounting location. See "D. Choosing Thermostat Location" on page (9).
4. (CCC 2 system only) Optional Indoor Temperature Sensor
  - a. Route an indoor temperature sensor (optional) from the roof opening to the indoor temperature sensor location. The 2 pin connector end goes to the roof opening. See indoor temperature sensor installation instructions for proper sensor location.
5. If system includes a gas furnace, route two 18 gauge thermostat wires from the furnace to the roof opening of the unit that will control it. If more than one furnace is to be used, route the second set of thermostat wires to the second unit. Make sure that at least 15" of wire extends into the opening.



# INSTALLATION INSTRUCTIONS

6. (CCC 2 system only) If an Energy Management System (load shed feature) is to be used with the control, two wires must be routed to the roof opening of the zone to be managed. The signal required for this function is normally an open relay contact. When the EMS calls for the compressor to shut off, the relay contacts should close. Make sure that at least 15" of the EMS wire extends into the roof opening.
7. (CCC 2 system only) If an Automatic Generator Start (AGS) kit will be installed, an additional 4 conductor communication cable must be routed from the last unit to the location of the AGS kit. Follow AGS kit instructions for installation.

## D. Choosing Thermostat Location

1. CCC 2 system without an optional indoor temperature sensor and LCD SZ system
  - a. The proper location of the thermostat is very important to ensure that it will provide a comfortable RV temperature. Observe the following rules when selecting a location.
    - Locate the thermostat 54" above the floor.
    - Install the thermostat on a partition, not on an outside wall.
    - **NEVER** expose the thermostat to direct heat from lamps, sun, or other heat producing items.
    - Avoid locations close to doors that lead outside, windows, or adjoining outside walls.
    - Avoid locations close to supply registers and the air from them.
2. CCC 2 system with an optional indoor temperature sensor in ALL zones
  - a. The thermostat may be mounted anywhere in the RV that is convenient. Try to avoid hard to reach and hard to see areas.
    1. Refer to the instructions provided with the indoor temperature sensor for details of installation.
3. When multiple single zone thermostats are being utilized, each individual thermostat **MUST** be installed in the room that the air conditioner is responsible for cooling to prevent air conditioners from attempting to turn on at the same time and overloading the breaker.

## E. Thermostat, Optional Indoor Temperature Sensor & Thermostat Communication Cable Installation

1. CCC 2 System
  - a. The previously run communication cable (4 conductor telephone cable) must be terminated with two (2) RJ-11-6C4P telephone

connectors. Refer to the crimp tool manufacturer for crimping instructions. See (FIG. 8) & (FIG. 9).

**i** RJ-11-6C4P connectors **MUST** be installed as shown in (FIG. 8) & (FIG. 9).

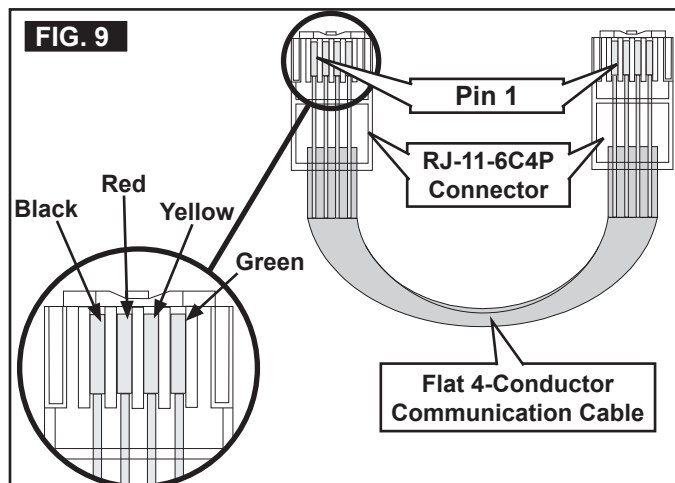
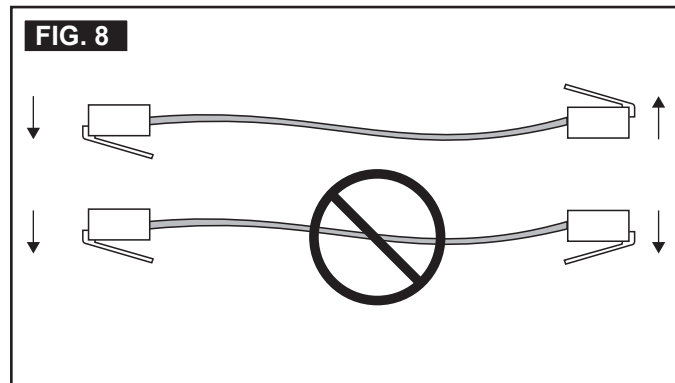

- b. Route the communication cable through the 2" diameter hole in the wall required for the thermostat. See (FIG. 10).

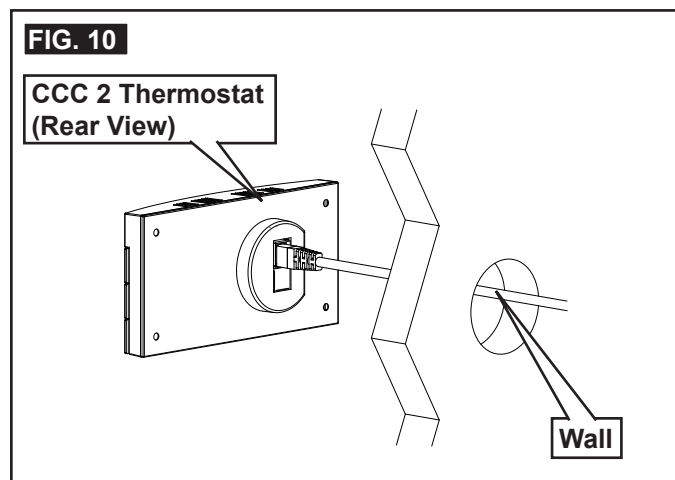

# INSTALLATION INSTRUCTIONS

- c. Optional Indoor Temperature Sensor
  - I. Refer to the instructions provided with the indoor temperature sensor for details of installation.
- d. Thermostat Installation
  - I. Carefully separate the thermostat base plate from the thermostat cover. Insert a small screw driver into the slot on bottom of thermostat and disengage the tab. See (FIG. 11).

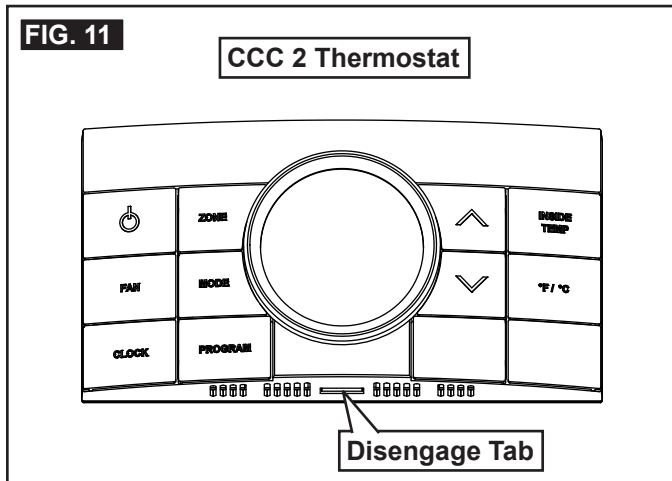

- II. Insert the 4 conductor communication cable through the hole in base plate. Align thermostat base plate with hole in wall. Make sure base plate is level and attach base plate to wall using the four (4) supplied screws.
- III. Insert the 4 conductor communication cable connector (RJ-11-6C4P) into the connector on the back of the thermostat. See (FIG. 12).

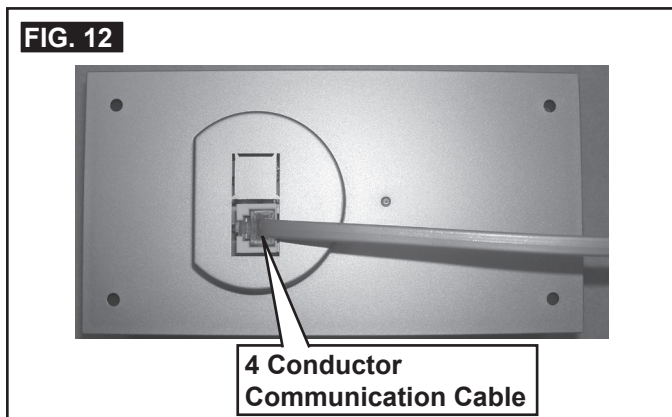

- IV. Align the thermostat with the back plate and snap into position.
2. LCD SZ System

 Wire colors listed for the communication

able (3 conductor cable) match the wire colors in the unit wire harness and the wire harness at the LCD SZ electronic control box. Available wire colors may vary.

- a. Remove the cover from the LCD SZ thermostat. Depress tab on bottom of thermostat and separate it from the base.
- b. Insert the previously run communication cable (3 conductor cable) through the hole in the base assembly.
- c. Cut back the outer cable shield approximately 3 inches and strip 1/4" insulation from each wire.
- d. Mount the thermostat level on the wall using the screws provided.
- e. Make the following connections to the thermostat. See (FIG. 13).

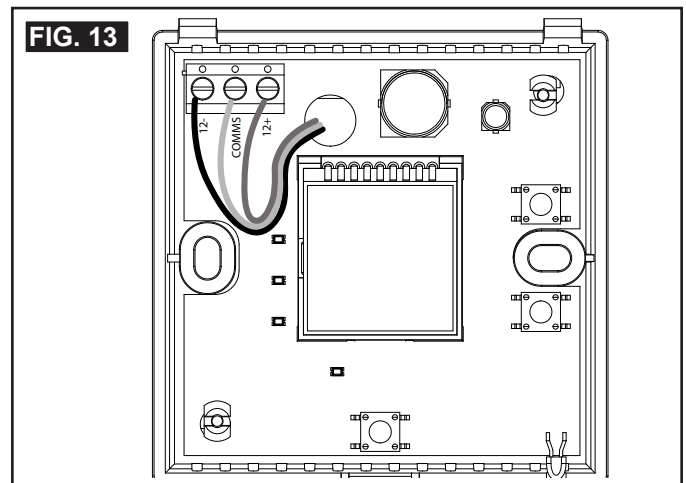

- Red/white wire to the 12V+ terminal
  - Black wire to the 12V- terminal
  - Orange wire to the "COMMS" terminal
- f. Inspect all connections to make sure they are tight and not touching any other terminals or wires.
  - g. Push the wires back through the base into the wall. Place cover on the thermostat and push until an audible click is heard.

## F. Placing Unit On Roof

1. Remove the unit from the carton and discard carton.
2. **CAUTION** LIFTING HAZARD. Use proper lifting technique and control when lifting product. Failure to obey this caution could result in injury. Place unit on the roof.
3. **NOTICE** Do **NOT** slide unit. Otherwise, damage to gasket (on bottom of unit) may occur, and could cause a leak.

# INSTALLATION INSTRUCTIONS

Lift and place the unit over the prepared opening using the gasket on the unit as a guide. See (FIG. 14).

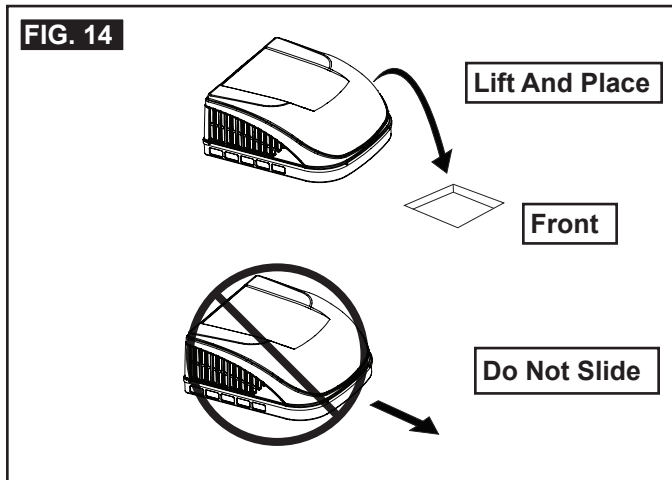

4. Place the electronic control box kit (if applicable) and the ADB kit inside the RV. These boxes contain mounting hardware for the unit and will be used inside the RV.

**i** This completes the outside work. Minor adjustments can be done from inside the RV if required.

## G. Installation Preparation

1. Check gasket alignment of the unit over the roof opening and adjust if necessary. Unit may be moved from below by slightly lifting. See (FIG. 15).

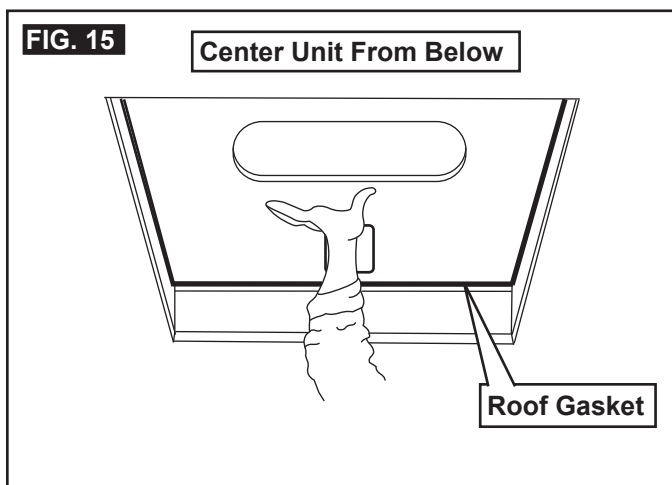

2. Remove ADB and mounting hardware from carton. See (FIG. 16).

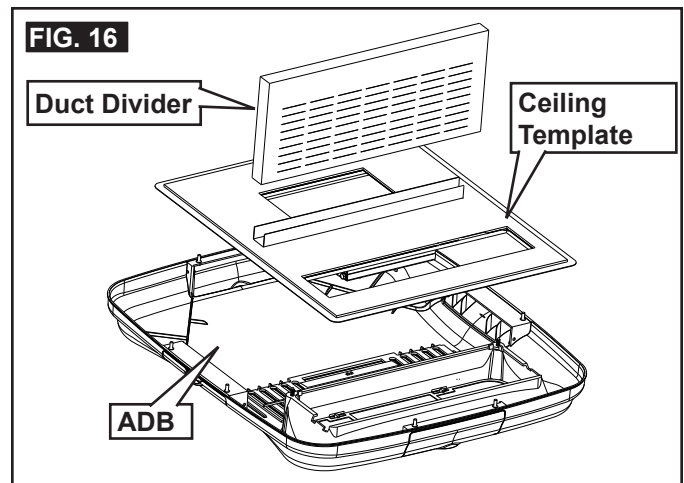

3. All models in this manual will use a four (4) bolt pattern for installing the ADB kit.

## H. 120 Vac Power Supply Connection

**i** For models 541815A, 541816A, 541915A, 541916A, 551816A, 551916A, 641815H, 641816H, 641835H, 651815H, and 651816H go to section "I".

1. **⚠ WARNING ELECTRICAL SHOCK HAZARD.** Make sure 120 Vac power is disconnected from RV. Failure to obey this warning could result in death or serious injury.
2. **⚠ WARNING ELECTRICAL SHOCK HAZARD.** Provide grounding in compliance with all applicable electrical codes. Failure to obey this warning could result in death or serious injury.
3. Reach up into the return air opening of the unit and pull down the unit electrical cord and power supply wires. See (FIG. 17), (FIG. 18) & (FIG. 19).

# INSTALLATION INSTRUCTIONS

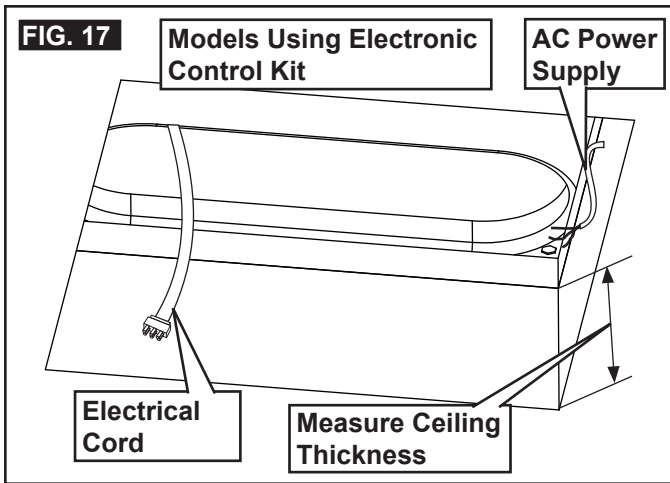

- For units with board built in, mount the junction box with screws to framing in front of roof opening and install strain relief. See (FIG. 18) & (FIG. 19).
- For units with plastic electronic control box, remove junction box cover. Save screws for reinstallation.

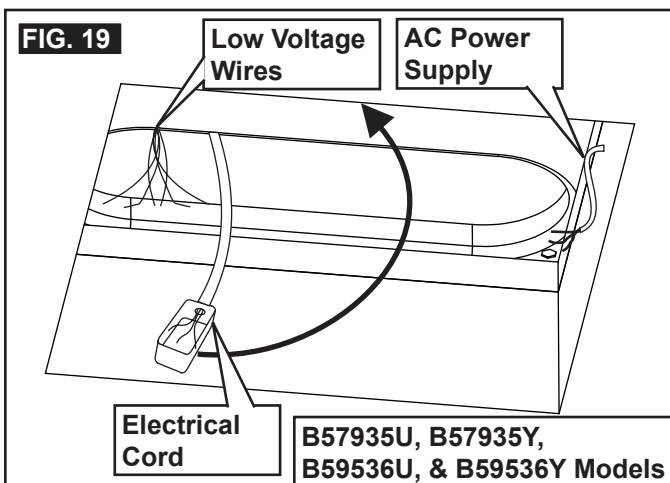
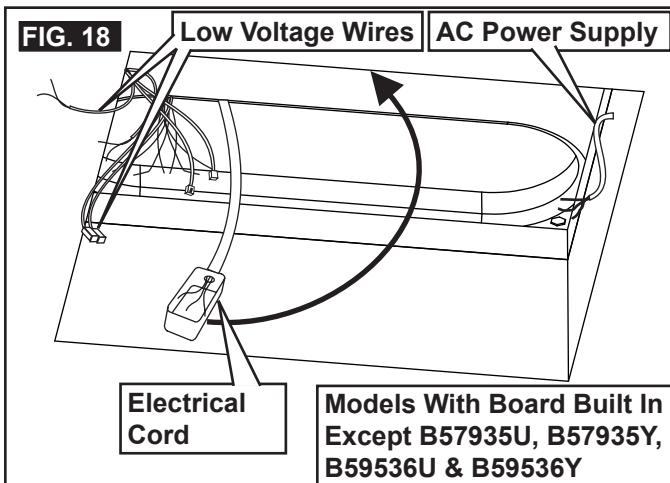

- Route the previously run 120 Vac power supply wire through the strain relief and into the junction box. Tighten strain relief making sure not to damage wires. Leave enough wire inside junction box to connect to unit 120 Vac wires.
- Connect white to white; black to black; and green to green or bare copper wire using appropriate size wire connectors.
- Tape the connectors to the supply wire to ensure they don't vibrate loose.
- Install junction box cover on all systems except CCC 2 electronic control box. Push the wires into the junction box and install junction box cover using screw(s) provided. The cover for CCC 2 electronic control box will be installed later.
- If the system has an electronic control box, plug the 6 pin electrical cord from the unit into the mating connector in the electronic control box. The plug is polarized and will only fit in one direction.

## I. 120 Vac Power Supply Connection For 541X1XA, 551X16A, 6418XXH, & 65181XH Models.

- ⚠ WARNING** ELECTRICAL SHOCK HAZARD. Make sure 120 Vac power is disconnected from RV. Failure to obey this warning could result in death or serious injury.
- ⚠ WARNING** ELECTRICAL SHOCK HAZARD. Provide grounding in compliance with all applicable electrical codes. Failure to obey this warning could result in death or serious injury.
- Reach up into the return air opening of the unit and pull down the unit electrical cord and power supply wires. See (FIG. 20).

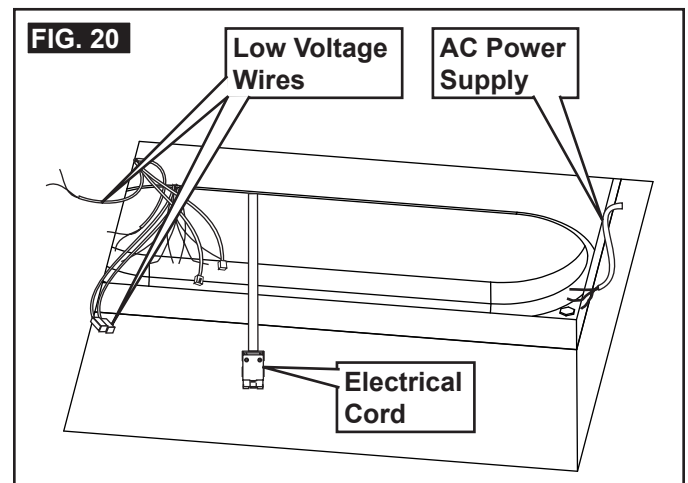

- Carefully strip and prepare 120 Vac supply wire. See (FIG. 21), (FIG. 22), (FIG. 23), (FIG. 24), & (FIG. 25).

# INSTALLATION INSTRUCTIONS

FIG. 21

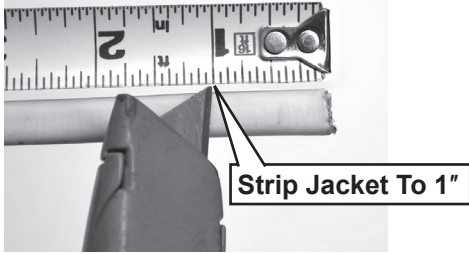

FIG. 22

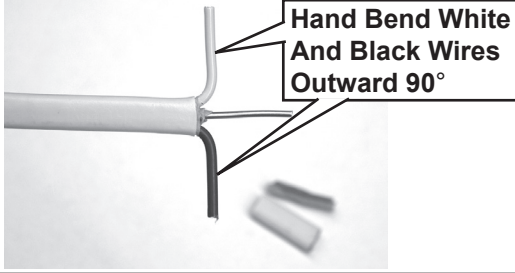

FIG. 23

Use Tip Of Pliers To Hold Wire In Place While Hand Bending Wire At 90°

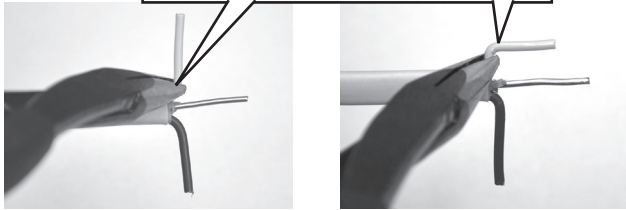

FIG. 24

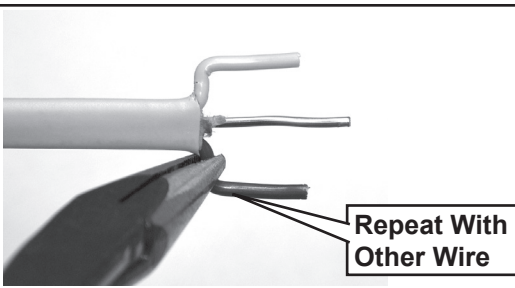
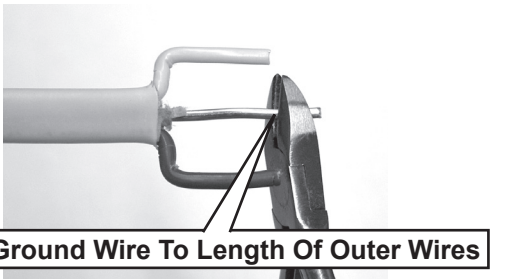
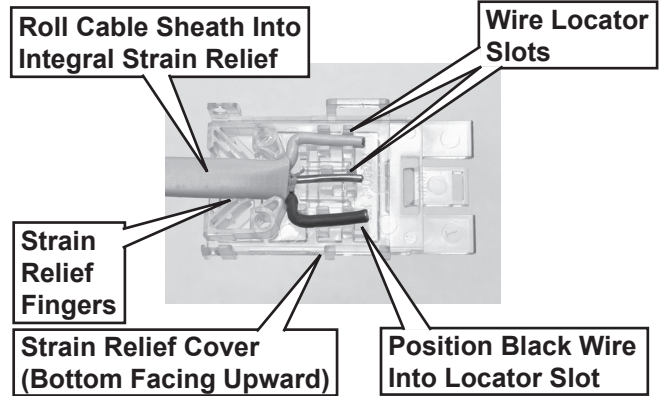

FIG. 25



5. Hold the clear strain relief cover with the bottom facing upward. See (FIG. 26).

FIG. 26 Load Cable into Strain Relief



6. Lay wire into locator slots, making sure the black wire is placed into the polarization slot. See (FIG. 26).
7. Press the cable sheath into the integral strain relief slot. See (FIG. 26). Trimming of ground wire and possibly others will be necessary. Wires must not extend beyond the locators. See (FIG. 27).

FIG. 27

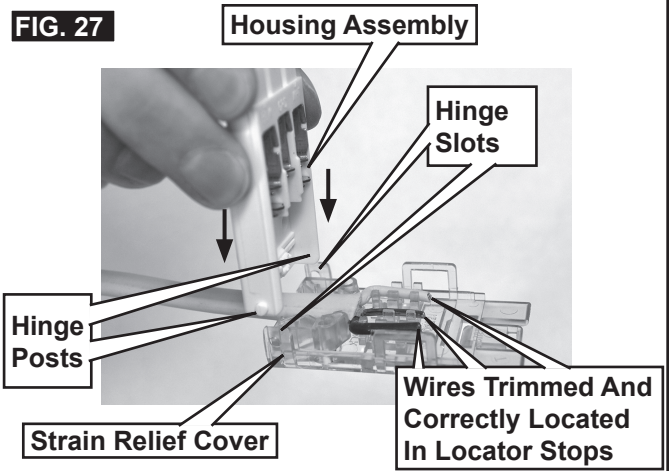

8. While holding the strain relief cover, position the housing's hinge posts into the hinge slots and press down until both lock into place. See (FIG. 27).
9. Close the strain relief cover and housing by hand. Squeeze the top and bottom closed with tongue and groove pliers. See (FIG. 28). Pliers must be a minimum of 10" long. Squeeze firmly on both sides, squarely across the connector between ribs A and B to ensure wires seat completely into slots.

# INSTALLATION INSTRUCTIONS

**FIG. 28** Attaching Housing Assembly To Strain Relief Cover With Tongue And Groove Pliers, Squeeze Squarely & firmly Between Ribs A & B

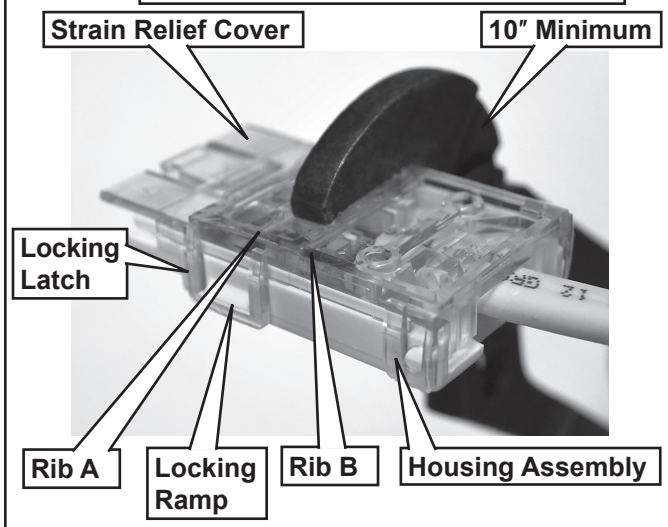

10. Inspect the connector to ensure the wires have been properly engaged into the housing assembly contacts. A properly terminated wire is fully seated into its proper slots with no significant bow of the cover. If the wires extend past the insulation stops the wires must be re-terminated with a NEW CONNECTOR. Once the cover has been closed the connector cannot be re-used. Failure to comply with this procedure may result in the failure of the connector.
11. Mating and un-mating the completed connector is illustrated below. See (FIG. 29).

**FIG. 29**

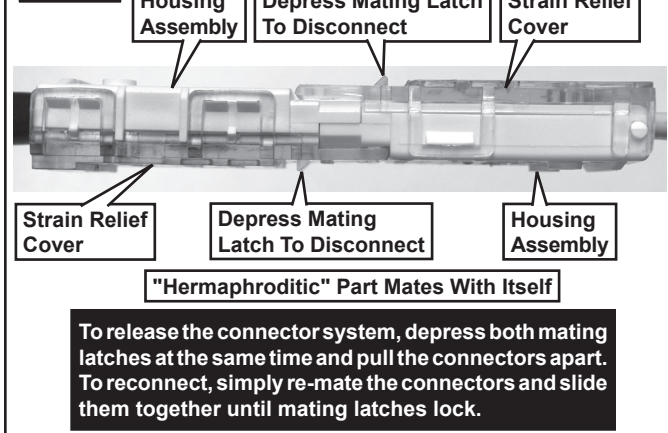

## J. Duct Divider Installation

1. Measure the ceiling thickness. See (FIG. 17).
2. Cut away the number of rows as indicated in table below. See (FIG. 30).

Ceiling Thickness		# Of Rows To Cut	Ceiling Thickness		# Of Rows To Cut
Min.	Max.		Min.	Max.	
6.0	6.5	0	3.5	4.0	5
5.5	6.0	1	3.0	3.5	6
5.0	5.5	2	2.5	3.0	7
4.5	5.0	3	2.0	2.5	8
4.0	4.5	4	1.5	2.0	9

**FIG. 30**

Remove Rows Starting Here

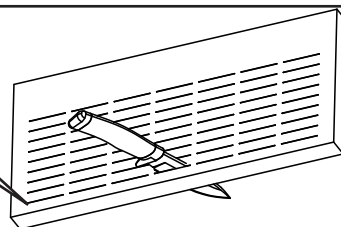

3. Carefully install the duct divider in the roof opening 5-5/8" from back of roof opening. See (FIG. 31).

**i** Foil back faces rear of unit.

**FIG. 31**

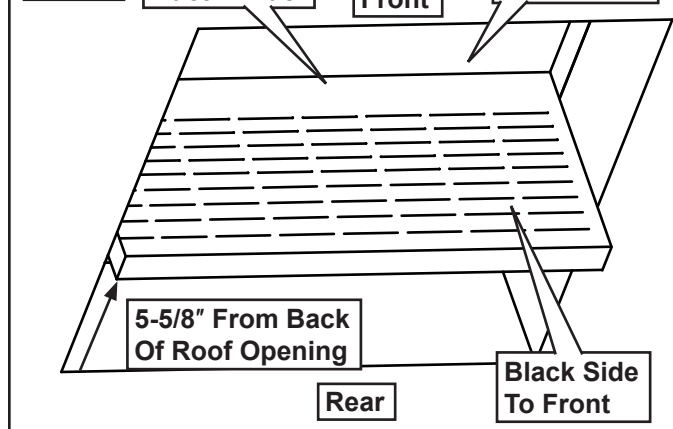

## K. LCD SZ System Low Voltage Wire Connections

**NOTICE** Make sure the positive (+) 12 Vdc terminal is disconnected from supply battery. Otherwise, damage to unit could occur.

1. Plastic Case Electronic Control Kit Systems Only
  - a. Plug the supplied freeze control sensor and the 4 wire harness into their matching connectors in the electronic control box.

# INSTALLATION INSTRUCTIONS

2. All Heat Pump Electronic Control Kit Systems
  - a. Plug the outdoor temperature sensor from the unit into the white 2 pin matching connector in the electronic control box.
3. All LCD SZ Electronic Control Kit Systems
  - a. Insert the freeze control sensor into the evaporator coil fins approximately 2" to 3" above the bottom of the coil fins and on the left side. See (FIG. 32). Bend fins over sensor to secure in place.

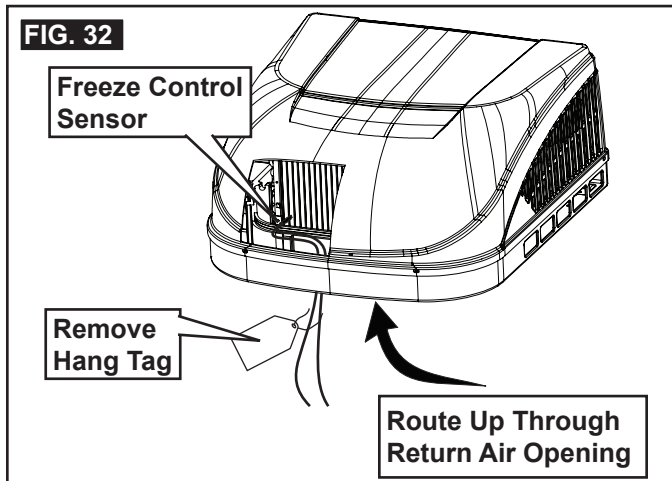

4. All LCD SZ Systems
  - a. Connect the previously run +12 Vdc supply wire to the red wire protruding from the roof opening or to the red wire at the electronic control box.
  - b. Connect the previously run -12 Vdc supply wire to both the black wire protruding from the roof opening or to the black wire at the electronic control box and to the wire of the three wire cable that goes to the thermostat 12V- terminal.
  - c. Connect the previously run furnace thermostat wires (if applicable) to the blue wires protruding from the roof opening or to the 1/4" connectors at the electronic control box using the supplied 1/4" insulated connectors. The polarity of this connection does not matter.
  - d. Connect the red/white wire protruding from the roof opening or the red/white wire at the electronic control box to the wire of the three wire cable that goes to the thermostat 12V+ terminal.
  - e. Connect the orange wire protruding from the roof opening or the orange wire at the electronic control box to the wire of the three wire cable that goes to the thermostat COMMS terminal.

## L. CCC 2 System Low Voltage Wire Connections

**NOTICE** Make sure the positive (+) 12 Vdc terminal is disconnected from supply battery. Otherwise, damage to unit could occur.

1. CCC 2 Electronic Control Kit Systems
  - a. Plug the 6 wire harness into the matching 6 pin connector in the electronic control box.
  - b. Plug the freeze control sensor into the P5 (Blue or Black) 2 pin matching connector in the electronic control box.
  - c. Insert the freeze control sensor into the evaporator coil fins approximately 1" above the bottom of the coil fins and on the left side. See (FIG. 32). Bend fins over sensor to secure in place.
2. All Heat Pump Electronic Control Kit Systems
  - a. Plug the outdoor temperature sensor from the unit into the P3 (white) 2 pin matching connector in the electronic control box.
  - b. Plug the 3 pin connector (reversing valve wire) from the unit into the 3 pin matching connector in the electronic control box.
3. All CCC 2 Systems
  - a. Connect the previously run 12 Vdc supply wires to the red and black wires protruding from the roof opening or the red and black wires in the 6 wire harness at the electronic control box. Connect +12 Vdc to the red wire; -12 Vdc to the black wire.
  - b. Connect the previously run furnace thermostat wires (if applicable) to the blue wires protruding into the roof opening or the blue wires in the 6 wire harness at the electronic control box. The polarity of this connection does not matter.
  - c. Terminate the 4 conductor communication cable(s) protruding from the roof opening. The cable(s) must be terminated with a telephone RJ-11-6C4P connector. Refer to the crimp tool manufacturer for crimping instructions.

 RJ-11-6C4P connectors **MUST** be installed as shown in (FIG. 8) & (FIG. 9).
  - d. Plug the 4 conductor communication cable into one of the couplers protruding from the roof opening or in the electronic control box. If more than one zone is used, the second coupler is used to join each additional zone.

# INSTALLATION INSTRUCTIONS

- e. Plug the indoor temperature sensor cable (if applicable) into the 2 pin matching connector protruding from the roof opening or the P4 (white) 2 pin matching connector in the electronic control box.
- f. Connect the previously run Energy Management System wires (if applicable) to the yellow wires protruding from the roof opening or the yellow wires in the 6 wire harness at the electronic control box. The polarity of this connection does not matter.
- g. If an automatic generator start (AGS) kit is installed, follow installation instructions furnished with AGS kit.

## M. (CCC 2 System Only) Configuration

### 1. Electronic Control Configuration

Depending on the equipment options installed by the RV manufacturer, the appropriate dip switches will need to be switched to the "ON" position. Placing the switch in the "ON" position selects that option. See (FIG. 33), (FIG. 34), (FIG. 35), & (FIG. 36).

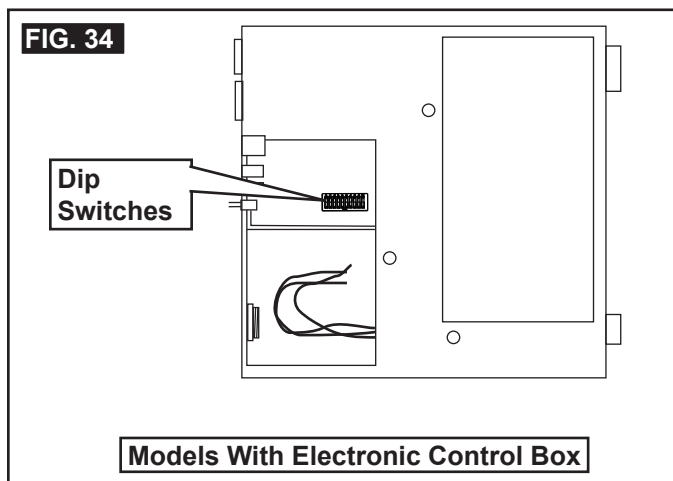
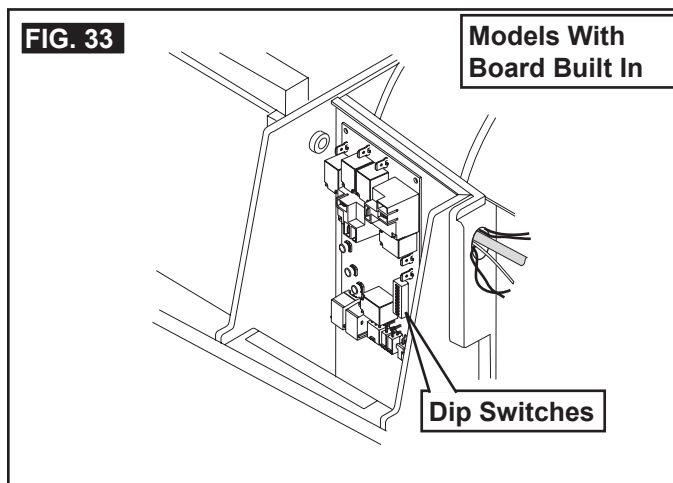

**i** Dip switches are in the "OFF" position when shipped from the factory except heat pump and factory installed heat strip models. On these models the appropriate dip switch, heat pump or heat strip, is in the "ON" position from the factory.

To gain access to the dip switches on models with board built in, the outside plastic shroud **MUST** be removed from the unit. Next remove the electrical box cover. The electrical box will be on the curb side of the RV after installation. See (FIG. 33).

Installations using the electronic control box the dip switches are visible through the opening in the electronic control box. See (FIG. 34).

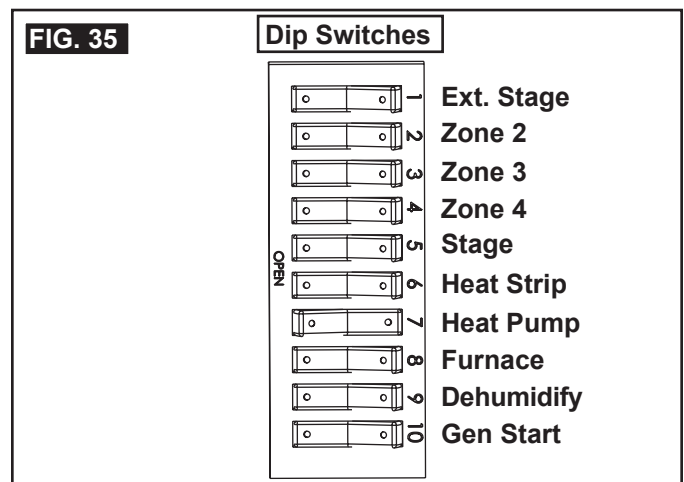

- a. Ext. Stage - Ext. Stage is not used on this unit. Leave in the "OFF" position.
- b. Zone selection - Each CCC 2 thermostat can have up to 4 zones. When only one unit is installed it becomes Zone 1 and no dip switch setting is required. Each additional unit must be assigned a zone (2 through 4). Each unit must have a different zone setting.
- c. Stage selection - Stage is not used on this unit. Leave in the "OFF" position.
- d. Heat Strip - On heat strip models the #6 dip switch is in the "ON" position from the factory. Non heat strip models leave in the "OFF" position.
- e. Heat Pump - On heat pump models the #7 dip switch is in the "ON" position from the factory. Non heat pump models leave in the "OFF" position.
- f. Furnace - If a Furnace/Aqua heat system has been connected to this unit, the furnace dip switch must be placed in the "ON" position.



# INSTALLATION INSTRUCTIONS

- g. Dehumidify - Dehumidify is not used on this unit. Leave in the "OFF" position.
- h. Gen Start selection - Leave in the "OFF" position.
- i. Install unit electrical box cover and out side plastic shroud or the electronic control box cover whichever applies.
- j. Repeat this procedure for each additional zone.

- 2. If your installation includes the optional electric heat kit, install it at this time. Follow the instructions with heat kit package for its installation procedure.
- 3. Ceiling Template Installation
  - a. Hold the ceiling template up to the roof opening and line up the channel in the ceiling template with the previously installed duct divider. See (FIG. 38).

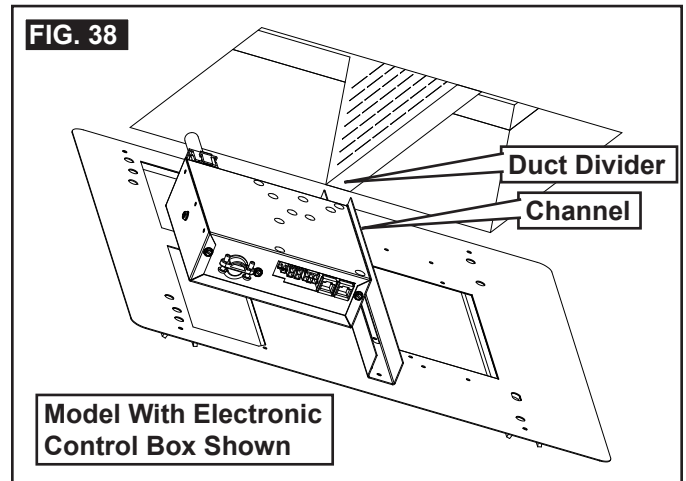
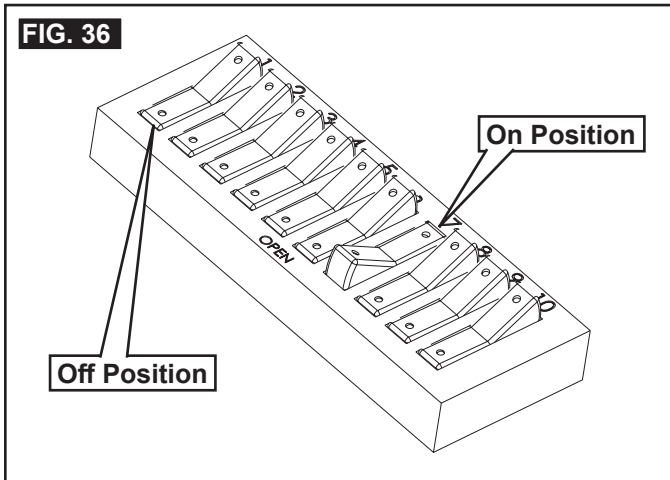

## N. Installing Unit

- 1. If system includes an electronic control box install it at this time. Make sure all wiring has been completed and that the electronic control box cover has been installed. To secure electronic control box to ceiling template drive two (2) #6 x 3/8" (plastic control box) or two (2) #10 x 3/8" (metal control box) blunt point Phillips head screws (provided) through the ceiling template and into holes in the electronic control box. See (FIG. 37).

- b. Hold the ceiling template up to the roof opening and start each mounting bolt by hand, through the ceiling template and up into the unit base pan. See (FIG. 39) & (FIG. 40).

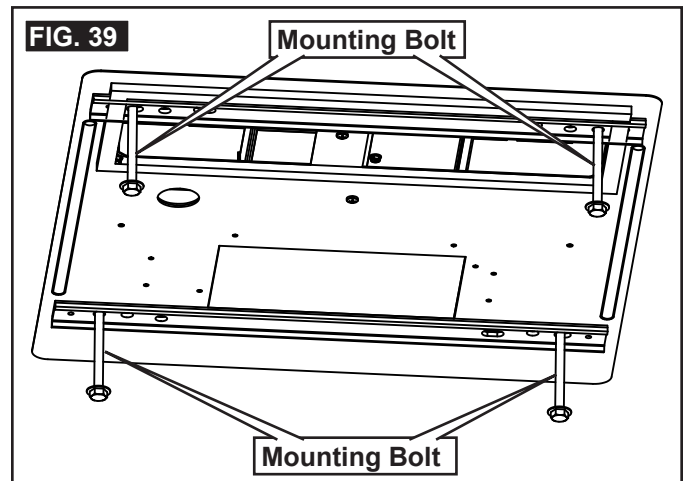
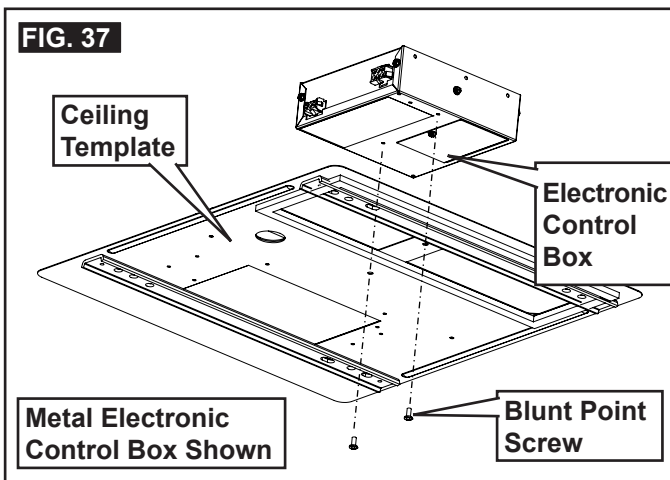

# INSTALLATION INSTRUCTIONS

Mounting Bolt Pattern Table See (FIG. 40)		Mounting Bolt Pattern Table See (FIG. 40)	
Model	Bolt Location	Model	Bolt Location
457915	A, D, E & H	541816	B, C, F & G
B57915	A, D, E & H	541915	B, C, F & G
B57935U	A, D, E & H	541916	B, C, F & G
B57935Y	A, D, E & H	551816	B, C, F & G
459186	A, D, E & H	551916	B, C, F & G
B59186	A, D, E & H	640310	B, C, F & G
459196	A, D, E & H	640312	B, C, F & G
B59196	A, D, E & H	640315	B, C, F & G
459516	A, D, E & H	641815	B, C, F & G
B59516	A, D, E & H	641816	B, C, F & G
459530	A, D, E & H	641835	B, C, F & G
B59530	A, D, E & H	641915	B, C, F & G
B59536U	A, D, E & H	641916	B, C, F & G
B59536Y	A, D, E & H	641935	B, C, F & G
540315	B, C, F & G	651815	B, C, F & G
540316	B, C, F & G	651816	B, C, F & G
541815	B, C, F & G	651916	B, C, F & G

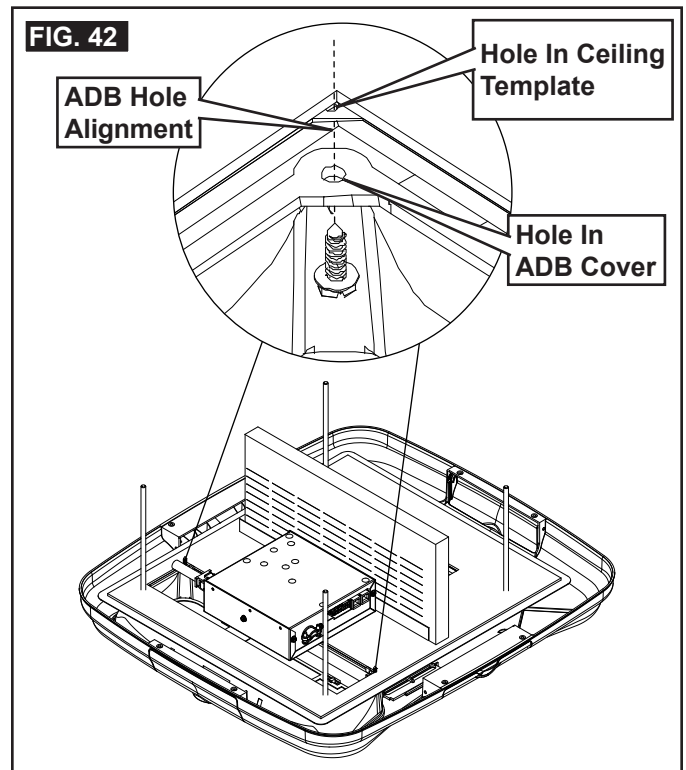
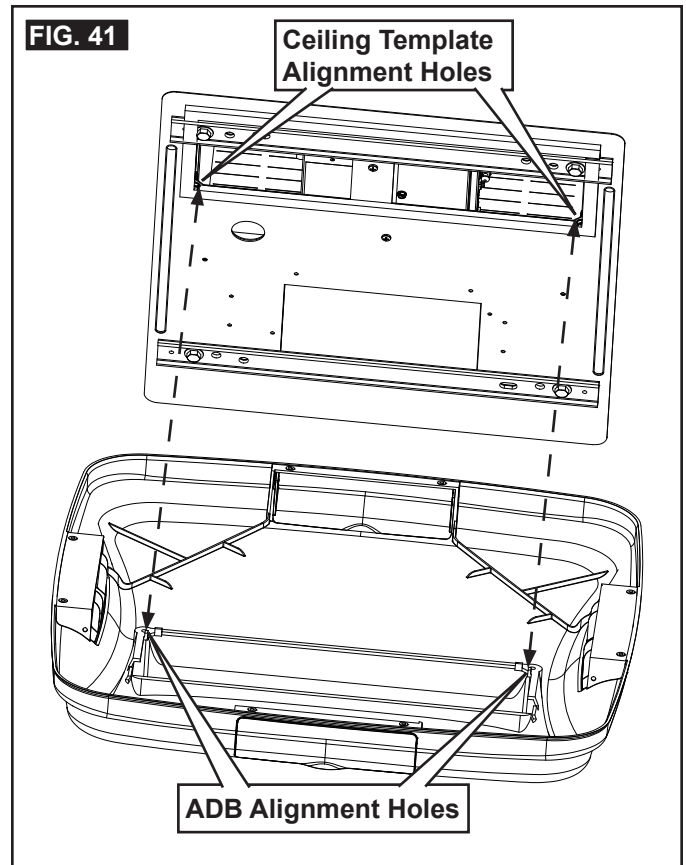
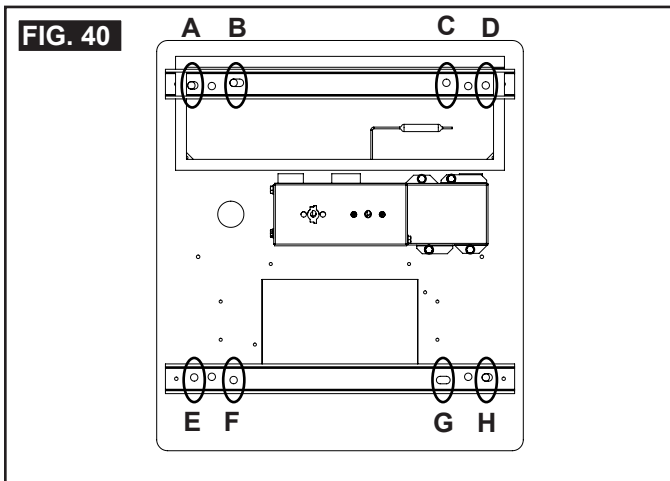

- c. **NOTICE** Tighten mounting bolts to correct torque specifications. Overtightening could damage unit's base pan or ceiling template. Not enough torque will allow an inadequate roof seal, and could cause a leak.
- d. Tighten all four (4) mounting bolts **EVENLY** with in 40 to 50 inch pounds. See (FIG. 39).

## O. Installing ADB

1. Align ADB with ceiling template. See (FIG. 41) & (FIG. 42).

**i** Front and rear vent doors are supplied loose. Do **NOT** install them until all screws are installed in step 2 & 3.

# INSTALLATION INSTRUCTIONS

2. Install two (2) (supplied) sheet metal screws inside return air opening to secure ADB to ceiling template. See (FIG. 43).
3. Install eight (8) (supplied) wood screws inside the front, rear, and side doors to secure ADB to ceiling. See (FIG. 43).

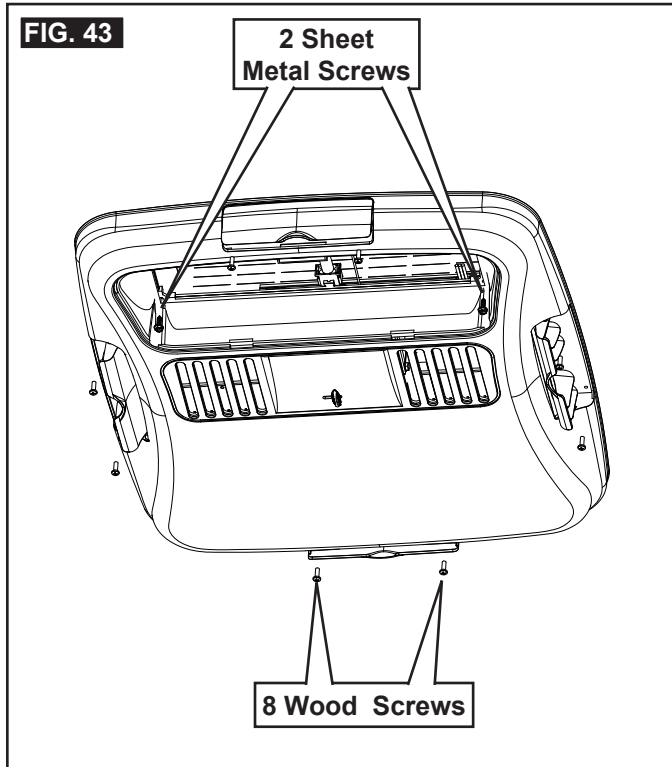

4. Install front and rear doors.
5. Place filter into return air vent grille. It may already be installed on some units. See (FIG. 44).

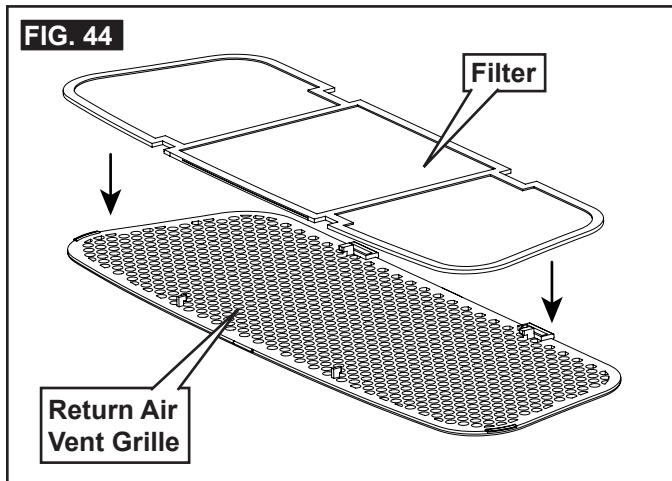

6. Install return air vent grille into the ADB. Slide return air vent grille tab into slot in ADB and rotate up and snap in place. See (FIG. 45).

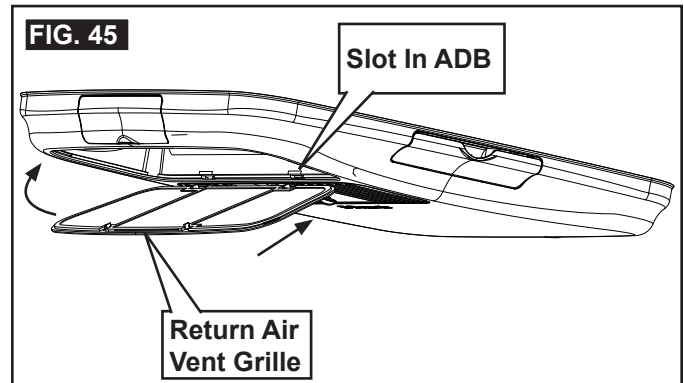

 This completes the LCD SZ system installation. (Proceed to section "P" to complete the CCC 2 system installation).

7. (LCD SZ System Only) System Checkout
  - a. Verify that all features of the system work. See the LCD SZ thermostat Operating Instructions or User's Guide. Reconnect the 12 Vdc and 120 Vac power supplies. Check fan speeds, cooling mode, heating mode, and furnace mode (if connected) operation. If features do not work, disconnect the 120 Vac and 12 Vdc power supplies and verify that all wiring is correct.

## P. (CCC 2 System Only) Reset & Checkout

1. System Reset

After setting the dip switches in the electronic control, do a system reset.

  - a. Re-connect the 12 Vdc and 120 Vac power supplies.
  - b. Make sure the CCC 2 thermostat is in the **OFF** mode.
  - c. Simultaneously press the **MODE** and **ZONE** buttons. The LCD will display "IniT" and all available zones.
  - d. Release the **MODE** and **ZONE** buttons.
  - e. Press the **ON/OFF** button to exit system set up.
  - f. When a dip switch is turned on after initial configuration, a system reset will need to be done before the CCC 2 thermostat will recognize the updated selection.

# INSTALLATION INSTRUCTIONS

2. System Checkout
  - a. Verify that all features of the installed system work. See CCC 2 thermostat Operating Instructions or User's Guide. Check the fan mode, cooling mode, heating mode (if applicable), and furnace mode (if applicable) operation. If features do not work, disconnect the 120 Vac and 12 Vdc power supplies and verify that all wiring is correct and that the correct dip switches have been set to the "ON" position.

## Q. (CCC 2 System Only) Furnace/Aqua Temperature Differential Setting

This system can be configured to operate using an ON/OFF differential of either 1 degree F or 2 degree F. See (FIG. 46).

1. To set the differential, simultaneously press the **PROGRAM** button and the **^** up button on the CCC 2 thermostat. "diF1" will appear in the display while the buttons are pressed. See (FIG. 46). To set the 2 degree differential, simultaneously press the **PROGRAM** button and the **∨** down button "diF2" will appear in the display while the buttons are pressed.

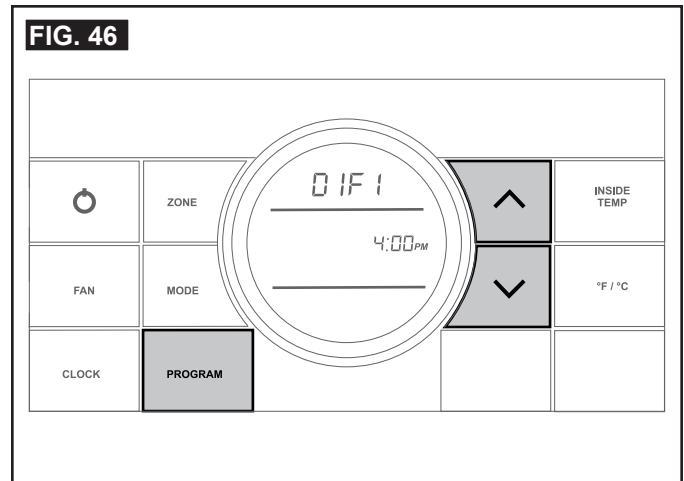

# GENERAL INFORMATION

## A. Frost Formation On Cooling Coil

Frost on a small portion of the coil is not unusual. Under certain conditions, ice may form on the evaporator coil. This is indicated by very cold output at very low air speed and the icing can be seen through the air inlet hole with the filter removed. If this should occur, inspect the filter and clean if dirty. Make sure air vents are open and not obstructed. Units have a greater tendency to frost when the outside temperature is relatively low. This may be prevented by adjusting the thermostat control knob to a warmer setting (counter clockwise). Should frosting continue, operate on any FAN ONLY setting until the cooling coil is free of frost; then resume normal operation. If frost condition persist, contact your local service center for assistance.

## B. Heat Gain

The ability of this air conditioner to maintain the desired inside temperature depends on the heat gain of the RV.

Some preventative measures taken by the occupants of the RV can reduce the heat gain and improve the performance of the air conditioner. During extremely high outdoor temperatures, the heat gain of the RV can may be reduced by:

1. Parking the RV in a shaded area
2. Using window shades (blinds and/or curtains)
3. Keeping windows and doors shut or minimizing usage
4. Avoid the use of heat producing appliances

Operation on High Fan/Cooling mode will give optimum or maximum efficiency in high humidity or high outside temperatures.

Starting the air conditioner early in the morning and giving it a "head start" on the expected high outdoor ambient will greatly improve its ability to maintain the desired indoor temperature.

For a more permanent solution to high heat gain, accessories like Dometic outdoor patio and window awnings will reduce heat gain by removing the direct sun. They also add a nice area to enjoy company during the cool of the evening.

## C. Condensation

The manufacturer of this unit will not be responsible for damage caused by condensation forming on ceilings, windows, or other surfaces. Air contains water vapor which condenses when temperature of a surface is below Dew point. During normal operation this unit is designed to remove a certain amount of moisture from the air, depending on the size of the space being conditioned. Keeping doors and windows closed when this air conditioner is in operation will greatly reduce the chance of condensation forming on interior surfaces.

## D. Air Distribution

Each A/C unit operating in cool mode, must have a minimum of 2 distribution vents, or the quick cool vent and one vent open, to avoid the risk of freezing coils and improper function.

# WIRING DIAGRAMS

## A. Simple RV Wiring Diagram

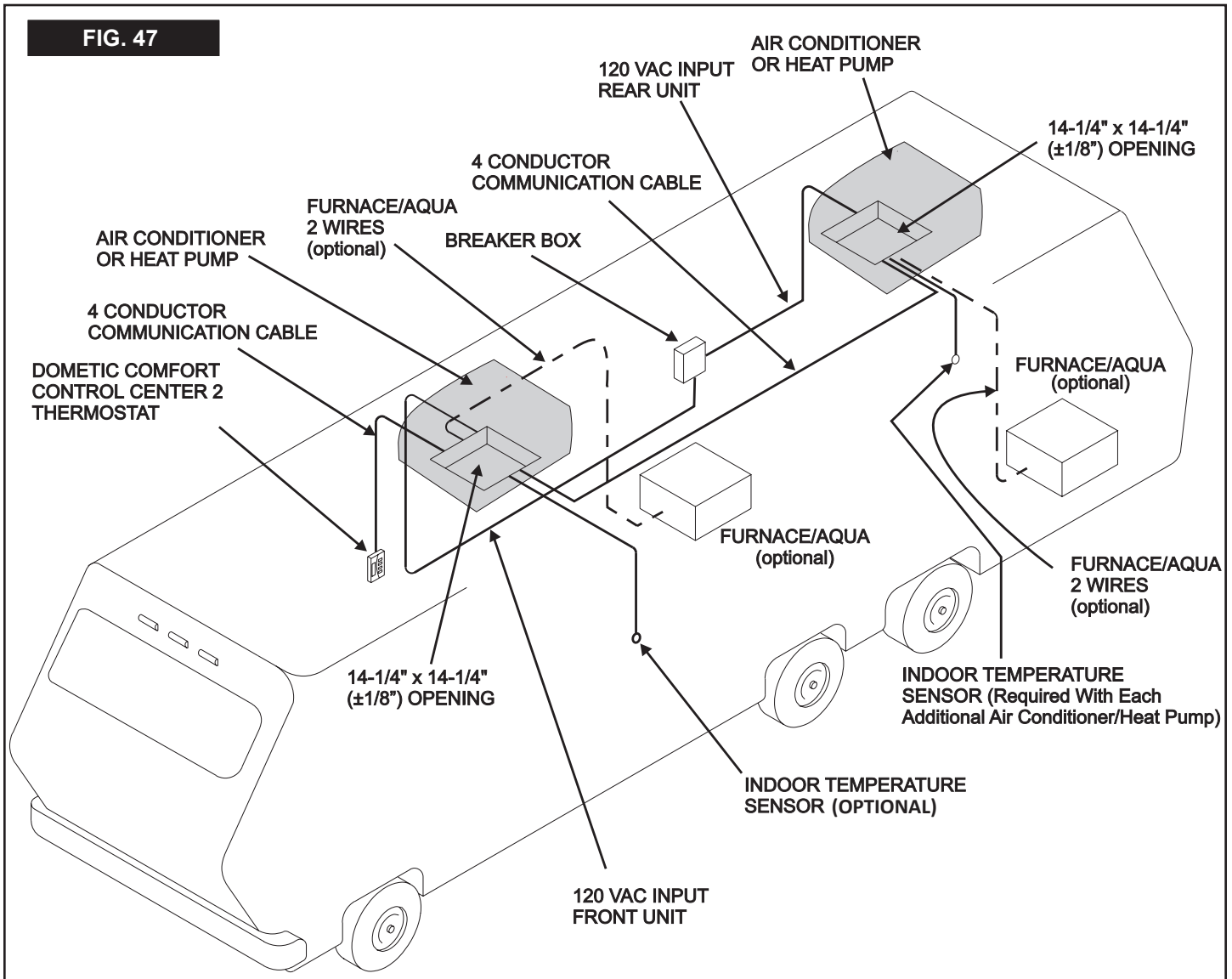

# WIRING DIAGRAMS

## B. Unit Wiring Diagrams

1. 457915, B57915, B57935U, B57935Y, 459516, B59516, 459530, B59530, B59536U, & B59536Y Unit Wiring Diagram

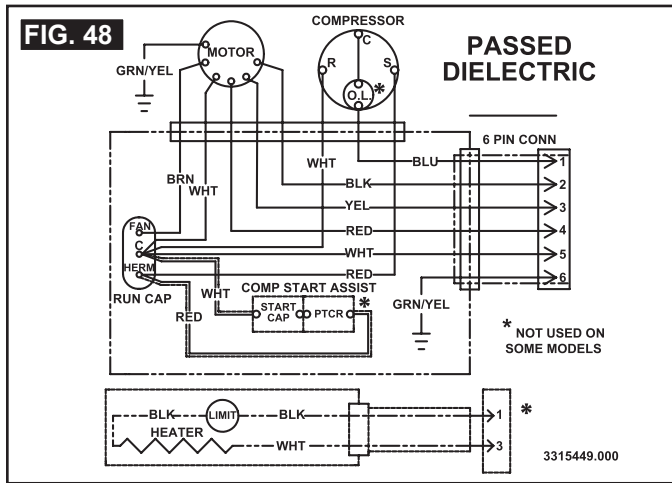

2. 459186 & B59186 Unit Wiring Diagram

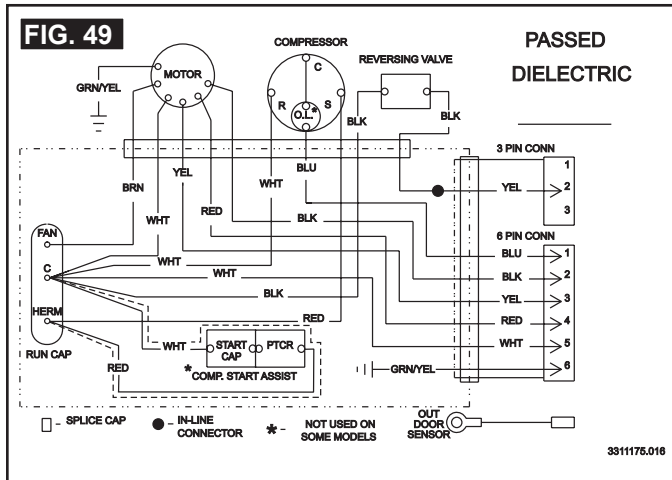

3. 459196 & B59196 Unit Wiring Diagram

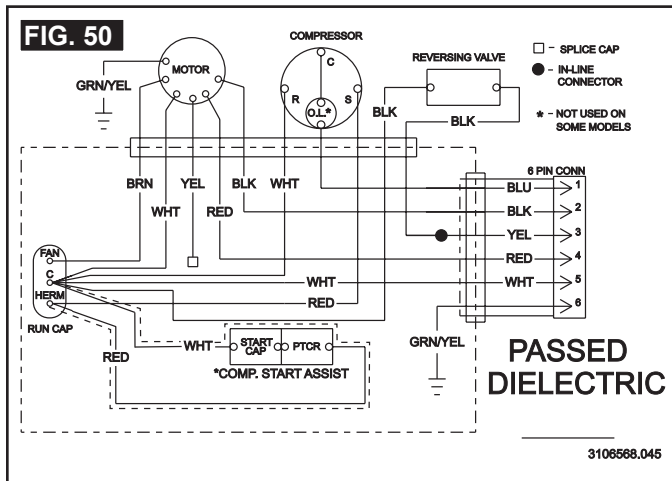

4. 540315 & 540316 Unit Wiring Diagram

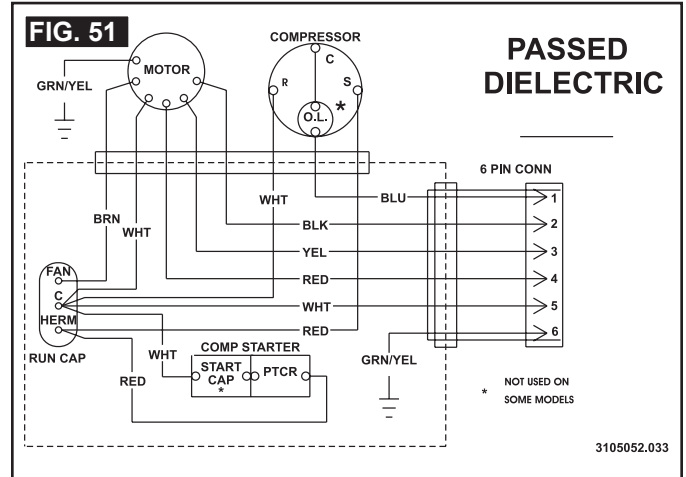

5. 541915 & 541916 Unit Wiring Diagram

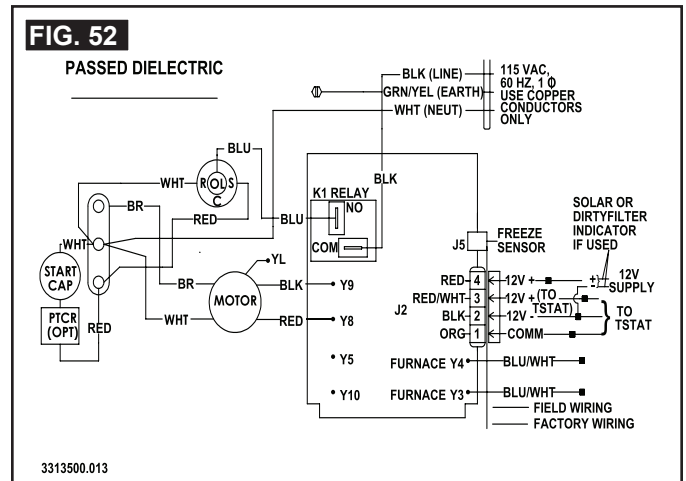

6. 551816, 651815, & 651816 Unit Wiring Diagram

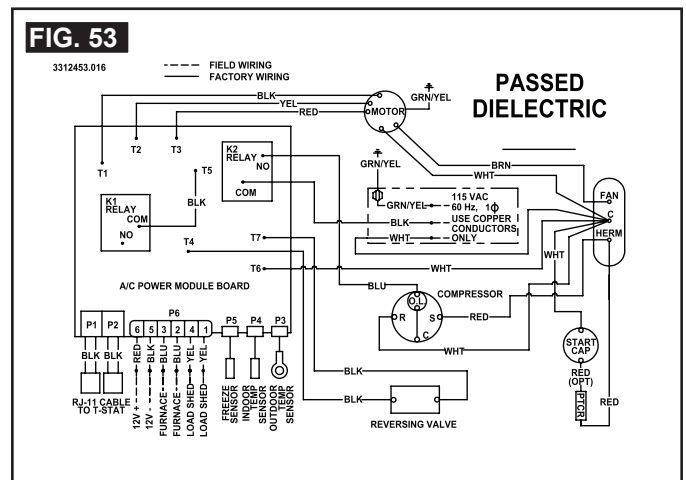





# WIRING DIAGRAMS

## C. Electronic Control Kit Wiring Diagrams

### 1. 3312020.000 CCC 2 Electronic Control Kit Wiring Diagram

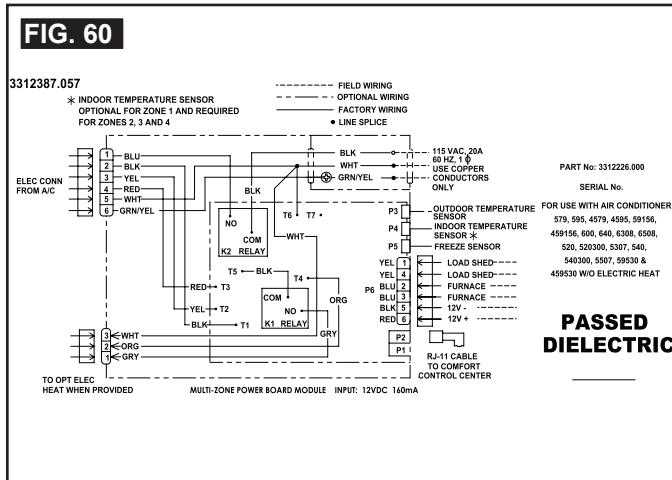

### 2. 3313189.000 & 3313189.015 LCD SZ Electronic Control Kit Wiring Diagram Cool/Furnace

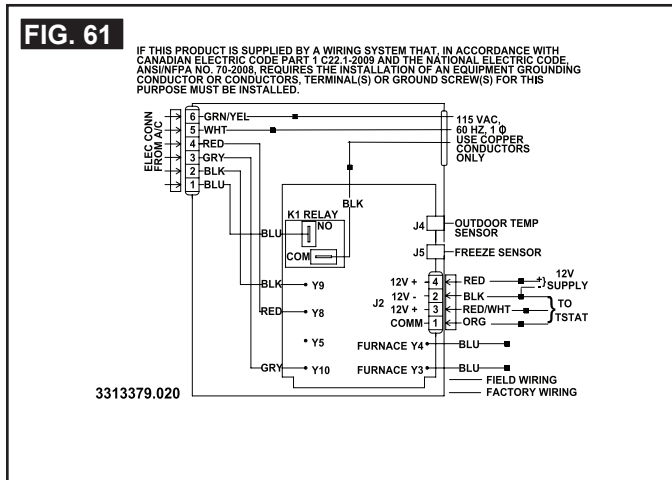

### 3. 3313189.049 & 3313189.056 LCD SZ Electronic Control Kit Wiring Diagram Cool/Furnace/HS

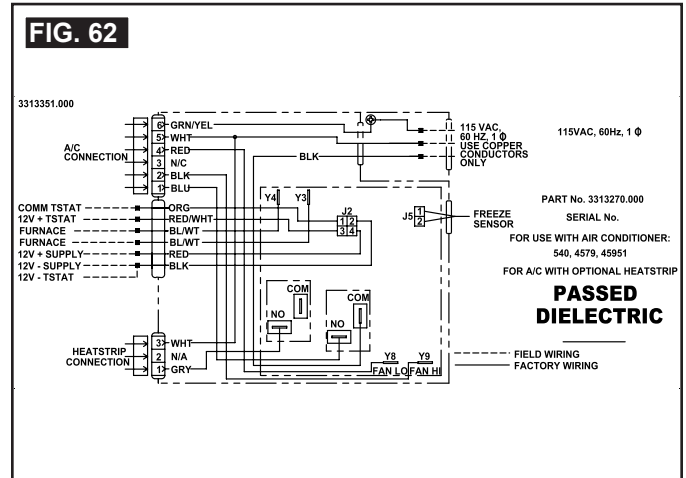

### 4. 3313189.064 & 3313189.072 LCD SZ Electronic Control Kit Wiring Diagram Cool/Furnace/HP

