



DiFlex II™ Roofing System RETRO-FIT INSTALLATION GUIDE

The instructions contained herein are guidelines for installing DiFlex II™ TPO roofing on older RVs. When applied using the proper techniques, materials and tools, the DiFlex II™ roof should provide years of dependable, trouble free performance.

To ensure proper warranty coverage, you should adhere to the installation techniques and materials described in this installation guide. Use of other procedures and products may jeopardize your warranty coverage.

NOTE: Read fully and understand the procedures before beginning installation.

GENERAL INFORMATION

1. Tools and Materials:

- A. Waterbased adhesive (901BA-5 or 917BA-5) is applied to a wood substrate with a roller. DiFlex II™ is applied while the adhesive is still wet.
- B. Butyl tape (BT-1834) must be under all vents and accessories on the roof and termination moldings that contact the TPO roofing. Butyl tape should also be used under the TPO membrane where it comes in contact with the unit body at the front, rear and side terminations.
- C. Lap Sealant (501LS) is a self-leveling caulk used to seal screw-type fasteners and termination moldings, formulated especially for DiFlex II™ TPO roofing.
- D. Paint roller (not supplied) should be a 9" wide short nap type. Used to apply waterbased adhesive (901BA-5 or 917BA-5).
- E. Push broom or squeegee (not supplied) used to remove air pockets and ensure that the DiFlex II™ membrane is completely in contact with the adhesive.
- F. Caulking gun (not supplied) used to apply lap sealant (501LS).
- G. Roof decking (substrate, not supplied), depending on the roof load requirements, should be at least 1/8" lauan plywood. If the load requirements are heavy (storage pods or consistent traffic) a minimum of 1/2" is recommended. In most new unit applications, 1/4" lauan or plywood is the minimum material used, while 3/8" material is more prevalent.

NOTE: Dicor does not warrant substrate material. Feel free to contact Dicor with any questions.

2. Cleaning Information:

DiFlex II™ TPO roofing can be cleaned with Dicor Rubber Roof Cleaner. For stubborn stains, products containing mineral spirits are recommended. **Do not use Acetone or Citrus Cleaners.**

Do not let any cleaning solvent come in contact with the membrane for extended periods of time.

Because dust and dirt may collect on the roof, regular cleaning with Dicor's RP-RC-160C or RP-RC320S Rubber Roof Cleaner is recommended. Do not park vehicle for extended periods where roof will be exposed to tree sap or fruit as staining may result.

A soft bristle brush may be used during cleaning.

PREPARATION

1. Remove all appliances, vents, moldings, etc. that may inhibit the current roofing material from being removed.
2. Evaluate the old roof. DiFlex II™ must have a sturdy foundation. Determine if the entire roof should be removed, or if the addition of decking (substrate) will be sufficient. Remember that the substrate must be securely fastened on all edges and seams.
3. Either remove the old roof or apply the substrate over the old roof, if removal will create structural damage.
4. When installing the substrate, make sure it extends to the edges of the roof. Also, make sure all seams are tight and as level as possible. The substrate should be installed using screw-type fasteners with screw heads level or slightly below the surface of the substrate. All substrate seams should be on a rafter for necessary support and to reduce the possibility of "seam separation". If seams are wider than 1/16" you may want to bridge seams with Dicor Fleece Tape 511FT. Additionally, if on the roof edge, the membrane will be going over a sharp edge, you should either bevel the edge of the substrate with a sander or place the Dicor Fleece Tape 511FT over the edge to protect the membrane from the edge.
5. Rout-out or cut all vent and appliance openings.
6. Sweep with a broom or blow-off of substrate all foreign materials and check entire roof for exposed screw heads or sharp objects that may prematurely wear the DiFlex II™ roof.

INSTALLATION

1. Locate the ends (front and rear) where the DiFlex II™ will be terminated. Use a chalk-line to mark these areas. Make sure there is sufficient roof structure to fasten to.
2. Cover the roof with the DiFlex II™ membrane making sure there is sufficient length at both the front and rear termination points. Fold membrane in-half, exposing the roof areas.
3. Open the waterbased adhesive (901BA-5 or 917BA-5) and stir thoroughly. Using a 9" wide short nap paint roller, apply adhesive to the substrate at a rate of 160 sq. ft. per gallon. The membrane is to be mated with the adhesive as quickly as possible.
4. Fold the membrane the opposite direction and repeat step #3.
5. With the membrane in place, adjust to make sure there is sufficient length at both termination points and on both sides of the vehicle. Remove wrinkles by lifting and pulling the membrane. Do not stretch the TPO membrane.
6. Lightly squeegee or use a push broom to eliminate air pockets, making sure the membrane is completely in contact with the adhesive.

7. Apply butyl tape (BT-1834) to the side of the roof edge molding. While holding the molding, draw surplus TPO membrane tight with a downward pull. Do not stretch the EPDM membrane. (You may staple the membrane in-place spacing $\frac{1}{2}$ " staples 3-5" apart to keep proper tension.) For best results, install this molding from the center of the vehicle toward the ends. When complete, use a utility knife to cut surplus material from below the molding. Repeat on opposite side.

NOTE: It may help to strike a chalk line to assist in keeping the side-body molding straight and in proper position.

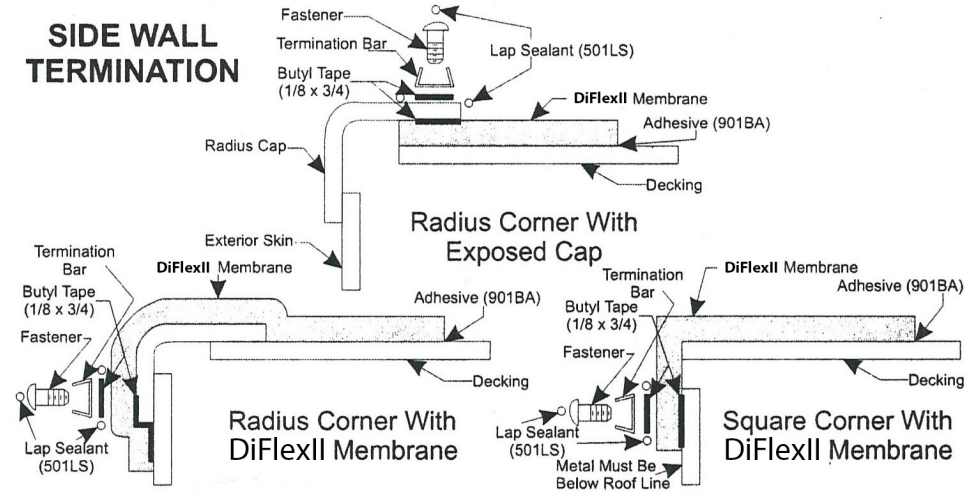

8. Apply butyl tape (BT-1834) to the termination molding. On the front of the vehicle, the front cap should lay on top of the membrane. Using a screw-type fastener, install the termination moldings – making sure there is sufficient roof structure. On the rear of the vehicle, the membrane should lay on top of the rear cap.

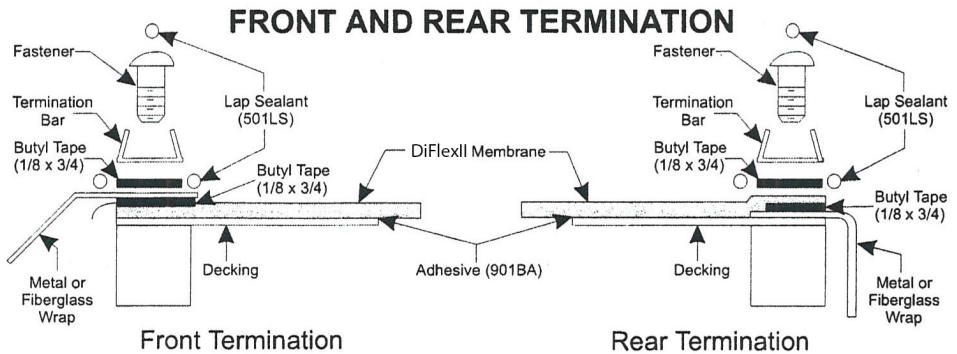

NOTE: Butyl tape should also be used under the TPO membrane where it comes in contact with the unit body at the front, rear, and side terminations. See all termination drawings for correct butyl placement.

9. Using a utility knife "X" cut all roof openings. Make sure all openings are cut the same size as previous openings. Round all 90 degree cuts to eliminate "running cuts". Surplus TPO membrane should be stapled inside vent openings. Do not stretch the TPO membrane. Trim all excess material.

10. Apply butyl tape (BT-1834) to all appliances, vents, etc. Re-install using screw-type fasteners. When installing the vents, appliances, etc., you may notice that the TPO membrane near the screws begins to “creep” and small air pockets form. Simply “Walk” the bubble toward the opening and hold-in-place while installing screw-type fasteners.

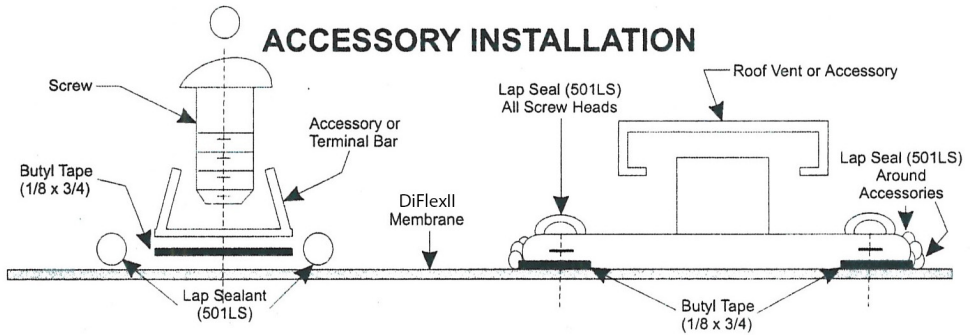

Caulk all screw heads, front and rear termination bar and all accessories.

Note: Only Butyl Tape can be used with DiFlex II™ membrane to assure proper seal.

11. Install lap sealant (501LS) using a ¼” to 3/8” bead, at the following locations:

- A. Bridging the membrane on all appliances
- B. Both ends of the front and rear termination molding
- C. Top edge of side roof edge molding.
- D. All screw heads located on the roof.

NOTE: 551LS Non-Leveling Sealant may be more suitable for use on accessories with taller flanges such as TV antennas, some skylights, etc.

NOTE: Do not use silicone – it will not adhere to DiFlex II™ TPO.

12. Clean all surplus caulk and debris from the roof.

Note: If the unite has a fiberglass or metal side radius cap, a bonding adhesive may be used in these areas. Normally, pulling the membrane tight under the side edge roof molding will be sufficient. If you determine a bonding adhesive is necessary please call Dicor for additional information.

the  **dicor** corporation
at the **cor** of everything you do.™

Learn more about RV roofing and sealants we have.