



**INSTALLATION INSTRUCTIONS
FOR
48000 SERIES
AIR CONDITIONERS**

These instructions are a general guide for installing the 48000 Series Coleman-Mach roof top air conditioners. For specific air conditioner details, it will be necessary to refer to the printed Customer Envelope Package supplied with each air conditioner.

IMPORTANT NOTICE

These instructions are for the use of qualified individuals specially trained and experienced in installation of this type equipment and related system components.

Installation and service personnel are required by some states to be licensed. **PERSONS NOT QUALIFIED SHALL NOT INSTALL NOR SERVICE THIS EQUIPMENT.**

NOTE

The words “Shall” or “Must” indicate a requirement which is essential to satisfactory and safe product performance.

The words “Should” or “May” indicate a recommendation or advice which is not essential and not required but which may be useful or helpful.

WARNING – SHOCK HAZARD

To prevent the possibility of severe personal injury or equipment damage due to electrical shock, always be sure the electrical power source to the appliance is disconnected.

CAREFULLY FOLLOW ALL INSTRUCTIONS AND WARNINGS IN THIS BOOKLET TO AVOID DAMAGE TO THE EQUIPMENT, PERSONAL INJURY OR FIRE.

WARNING

Improper installation may damage equipment, can create a hazard and will void the warranty.

The use of components not tested in accordance with these units will void the warranty, may make the equipment in violation of state codes, may create a hazard and may ruin the equipment.

I. GENERAL INFORMATION

OEM – Please make sure the Customer Envelope Package accompanies the air conditioner.

INSTALLER AND/OR DEALER – Please make sure the Customer Envelope Package is presented to the product consumer. The product consumer should also be afforded the opportunity to purchase the optional three (3) year parts replacement contract available from Airxcel, Inc.

INQUIRIES ABOUT THE A/C UNIT – Inquiries to your Airxcel, Inc. representative or to Airxcel, Inc. pertaining to product installation should contain both the model and serial numbers of the roof top air conditioner. All roof top air conditioning units have model and serial number identification in two locations; (1) rating plate sticker may be viewed by looking through the shroud louvers on the compressor side of the roof top air conditioning unit. The rating plate sticker can be seen without removing the outer plastic shroud, (2) model/serial number sticker (silver color) is located on the bottom of the basepan of the roof top air conditioner. If the air conditioner is installed, the sticker may be viewed by lowering the ceiling assembly shroud.

II. AIR CONDITIONING SIZING

The ability of an air conditioner to provide a comfortable environment for the consumer is dependent upon the following conditions.

Air conditioners are rated primarily by their ability to remove heat. The thermal measurement used for detecting a gain or loss of heat is the British Thermal Unit (BTU). One (1) BTU is the amount of heat required to raise the temperature of one pound of water by one degree Fahrenheit. An air conditioner rated at 13,500 BTUH can remove 13,500 BTU's of heat in one hour.

The ability of an air conditioner to cool down a vehicle or maintain a consumer desired temperature is dependent upon the heat gain of the vehicle. The physical size, the amount of window area, the quality and amount of insulation, the position exposure to sunlight, the number of people using the vehicle and the outside temperature may increase the heat gain to such an extent that the capacity of the air conditioner is exceeded.

As a general rule, air supplied (discharge air) from the air conditioner will be 15 to 20 degrees cooler than the air entering (return air) the ceiling assemblies bottom air grilles.

For example, if the air entering the air conditioner is 80 degrees F. (return air), the supply air (discharge air) into the vehicle will be 60 to 65 degrees F. As long as this temperature difference (15 to 20 degrees) is being maintained at the air conditioner, the air conditioner is operating properly.

Again, give careful consideration to the vehicle heat gain variables. During extreme outdoor temperatures, the heat gain of the vehicle may be reduced by:

- Parking the vehicle in a shaded area
- Keeping windows and doors closed
- Avoiding the use of heat producing appliances
- Using window shades (blinds and/or curtains)

For a more permanent solution to high heat gain situations, additional vehicle insulation, window awnings and/or window glass tinting should be considered.

III. SELECTING AN INSTALLATION LOCATION

Your Airxcel, Inc. air conditioner has been designed for use primarily in recreational vehicles.

Is the roof of the vehicle capable of supporting both the roof top unit and ceiling assembly without additional support structures? Inspect the interior ceiling mounting area to avoid interference with existing structural members such as: bunks, curtains, tracks or room dividers. The depth of the ceiling assembly shroud is 3". Be sure to check clearance for doors which must be swung open (refrigerator, closets, cabinets).

Most of the time, roof mount air conditioners are installed at existing roof vent locations. If there are no roof vents (existing mounting hole), the following placement locations are recommended.

Motor Homes – a single unit or the forward of two units should be mounted within 9 feet of the drivers compartment.

Travel Trailers or Mini-Homes – a location should be selected that is near the door slightly forward of the vehicle center length.

Vans – location should be in the center of the roof (side to side – front to back).

Truck with Camper – location should be between 4 or 5 feet from the rear of the camper to achieve maximum cooling effect.

IV. INSTALLING THE ROOF TOP UNIT

DANGER SHOCK HAZARD

DISCONNECT ALL POWER TO THE VEHICLE BEFORE PERFORMING ANY CUTTING TO THE VEHICLE. CONTACT WITH HIGH VOLTAGE CAN RESULT IN EQUIPMENT DAMAGE, PERSONAL INJURY OR DEATH.

IMPORTANT

TO PREVENT DAMAGE TO THE WIRING AND BATTERY, DISCONNECT THE BATTERY CABLE FROM THE POSITIVE BATTERY TERMINAL BEFORE PERFORMING ANY CUTTING TO THE VEHICLE.

If the air conditioner is being installed on a low friction roof surface such as aluminum, steel or gelcoat fiberglass, it is advisable to order a spring pad kit, part number 8333-3871 to add "spring pads" to maintain bolt tension and retard lateral motion of the air conditioner which could shear the mounting bolts.

If the air conditioner is being installed subject to heavy lateral loads, it is advisable to order a “Roughneck” gasket/bolt package, part number 48207-3301 to maintain bolt tension, prevent lateral movement of the air conditioner and guard against bolt shear.

Once the location for your air conditioner has been determined (See Section III), a reinforced and framed roof hole opening must be provided (may use existing vent hole). Before cutting into the vehicle roof, verify that the cutting action will clear all structural members and crossbeams. Additionally, the location of any inner roof plumbing and electrical supplies must be considered.

- A. If a roof vent is already present in the desired mounting location for the air conditioner, the following steps must be taken.
1. Remove all screws which secure the roof vent to the vehicle. Remove the vent and any additional trim materials. Carefully remove all caulking from around the roof vent opening to obtain clean exterior roof surface.
 2. It may be necessary to seal some of the old roof vent mounting screw holes which may fall outside of the air conditioner basepan gasket.
 3. Examine the roof opening. If the opening is smaller than 14” x 14”, the opening must be enlarged. If the opening exceeds 15” x 15”, a mounting frame must be field fabricated to reduce the opening size (See Figure 1).
- B. If a roof vent opening is not used, a new opening (See Figure 1) will have to be cut into the vehicle roof. A matching opening will also have to be cut into the interior vehicle ceiling. Be careful when cutting the ceiling opening. If the ceiling opening is carpeted, snagging could occur. After the opening in the roof and interior ceiling are the correct size, a framed support structure must be provided between exterior roof top and interior ceiling. The reinforced framed structure must provide the following guidelines:

1. Capable of supporting both the weight of the roof top air conditioner and the interior ceiling assembly.
2. Capable of holding or supporting the roof outer surface and interior ceiling apart, so that when the roof top air conditioner and ceiling assembly are bolted together, no collapsing occurs.

Airxcel’s 48000 series requires that the spacing from the vehicle roof top to the interior ceiling be no less than 1”. A typical support frame is shown in Figure 1.

The frame must provide an opening to allow passage for the power supply wiring. Route the supply wiring through the frame at the same time the support frame is being installed.

IMPORTANT – Allow 24” of supply wiring through the support frame (working length).

After the support frame is installed, seal off **all gaps** between the frame and both the roof exterior and the interior ceiling of the vehicle (cavity walls). Additionally, seal the gap around the electrical supply wiring.

- C. This air conditioner is to be installed in accordance with NFPA Standard 501C.
- D. The roof top air conditioner must be mounted as near level from front to rear and side to side as is possible when the vehicle is parked on a level plane. Figure 2 shows maximum allowable degree deviations (mounting degrees from total surface flat plane).

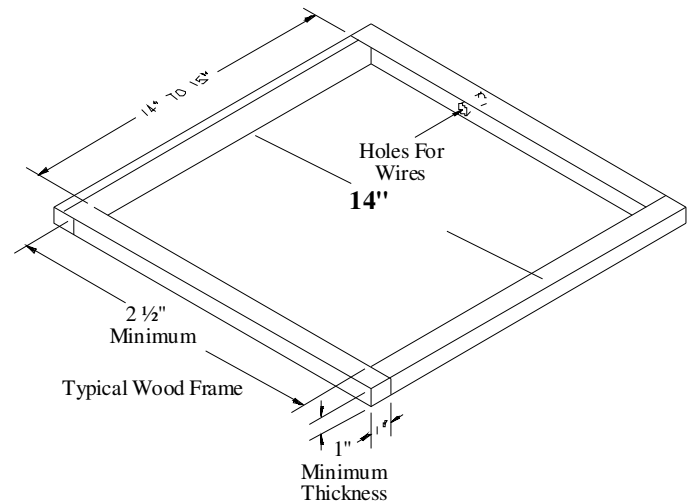

FIGURE 1

ALLOWABLE FRONT TO BACK TILT

ALLOWABLE SIDE TO SIDE TILT

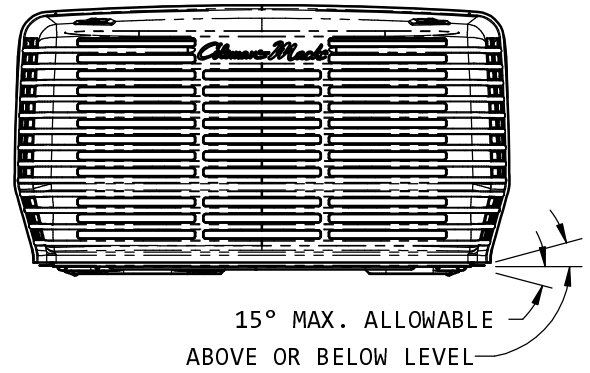
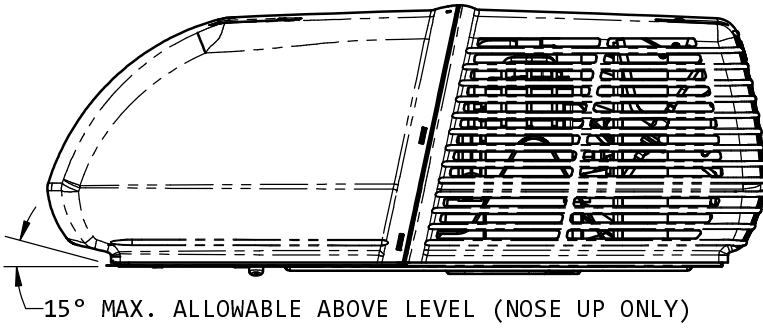

FIGURE 2

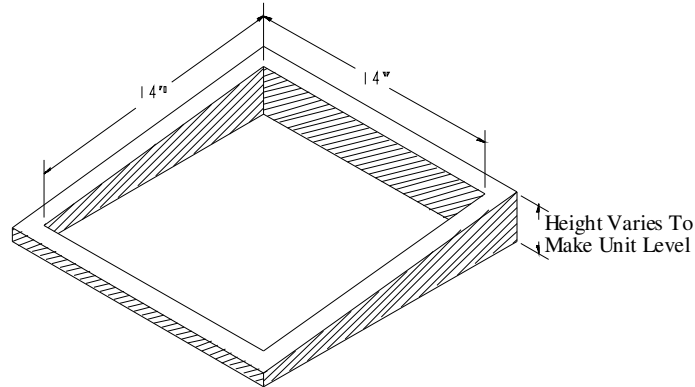

FIGURE 3

If the roof of the vehicle is sloped (not level) such that the roof top air conditioner cannot be mounted within the maximum allowable degree deviations, an exterior leveling shim will need to be added to make the roof top air conditioner level. A typical leveling shim is shown in Figure 3.

- E. After the mounting hole area is properly prepared, remove the carton and shipping pads from the roof top air conditioner. **Carefully** lift the unit to the top of the vehicle. **Do not use the outer plastic shroud for lifting.** Place the roof top air conditioner over the prepared mounting hole. The pointed end (nose) of the shroud must face towards the front of the vehicle. Pull the electrical conduit down from the roof air conditioner through the mounting opening and let hang.

V. SECURING THE AIR CONDITIONER TO THE ROOF

A mounting frame is supplied with the ceiling assembly. Follow the steps below to secure the air conditioner to the roof. Refer to Figure 4.

- A. Locate the air conditioner mount gasket over the 14" to 15" square opening in the roof.
- B. Install the ceiling assembly mount frame using the four bolts found with the ceiling assembly.

- C. Proper tension has been achieved for each bolt when any portion of each gasket indicating tab has been pulled down even with the roof. See Figure 4. The upper unit has now been properly installed with optimum gasket compression.

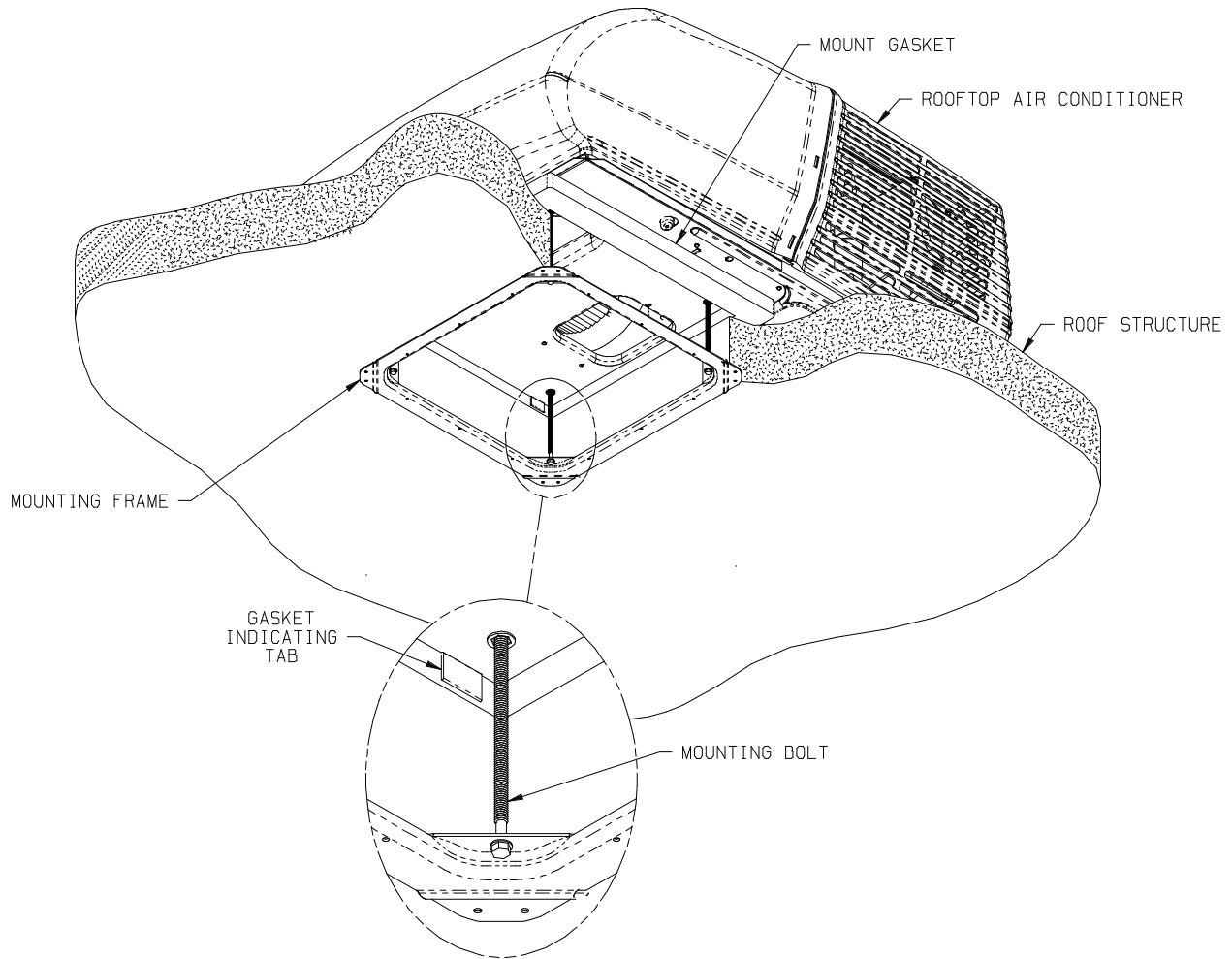

FIGURE 4

VI. ELECTRICAL WIRING

ROUTING 115 VAC WIRING

TH

Following Airxcel's high voltage wiring specifications and all local and national electrical codes, route the roof top unit 115 VAC supply wiring from its power source to the wirebox.

High Voltage Wiring Specifications based on Minimum Overcurrent Protection Device Amperage – (see upper unit nameplate)

1. U.L. requires copper conductors only with minimum #12 AWG when using the minimum recommended overcurrent protection device. Higher rated devices or longer wiring runs will require #10 AWG or greater copper conductors.
2. To prevent voltage drops greater than 10% during starting loads, adhere to the following guideline:

For lengths greater than 50', use #10 AWG or larger copper conductors. Match to the overcurrent protection device provided.
Circuit Protection – Refer to upper unit nameplate.

High Voltage Wiring Specifications based on Overcurrent Protection Device rated higher than the minimum required (see upper unit nameplate)

Follow all local and NEC (National Electrical Code) for proper sizing of wire AWG based on Overcurrent Protection Device selected and the length of the wiring run to the air conditioner.

DANGER – SHOCK HAZARD

MAKE SURE THAT ALL POWER SUPPLY TO THE UNIT IS DISCONNECTED BEFORE PERFORMING ANY WORK ON THE UNIT TO AVOID THE POSSIBILITY OF SHOCK INJURY OR DAMAGE TO THE EQUIPMENT.

DANGER

WHEN USING NON-METALLIC SHEATH CABLES (ROMEX, ETC.), STRIP SHEATH BACK TO EXPOSE 4-6 INCHES OF THE SUPPLY LEADS.

STRIP THE INDIVIDUAL WIRE LEAD ENDS FOR WIRE CONNECTION (ABOUT 3/4" BARE WIRE). INSERT THE SUPPLY WIRES INTO THE ELECTRICAL CONNECTOR CLAMP. SHEATH MUST PROTRUDE PAST THE CLAMP BUSHING INSIDE THE BOX AS ILLUSTRATED. MAKE SURE SHEATH CABLE IS CENTERED IN CLAMP BEFORE TIGHTENING UP ON IT. DO NOT OVERTIGHTEN!!

THIS COULD RESULT IN PINCHING THROUGH THE PLASTIC WIRE INSULATION AND CAUSE SHORTING OR "HOT" WIRES TO GROUND (SHOCK HAZARD). THE CLAMP IS INTENDED FOR STRAIN RELIEF OF THE WIRES. SLIGHT PRESSURE IS USUALLY SUFFICIENT TO ACCOMPLISH THIS.

IF OTHER THAN NON-METALLIC CABLES ARE USED FOR SUPPLY CONDUCTORS, APPROPRIATE STRAIN RELIEF CONNECTORS OR CLAMPS SHOULD BE USED.

IN NO CASE SHOULD CLAMPING OR PINCHING ACTION BE APPLIED TO THE INDIVIDUAL SUPPLY LEADS (NEUTRAL AND "HOT" WIRES).

DANGER SHOCK HAZARD

TO PREVENT THE POSSIBILITY OF SHOCK INJURY, THE WHITE WIRE MUST BE CONNECTED TO NEUTRAL IN THE SERVICE BOX ENTRANCE AND THE MECHANICAL GROUND MUST BE CONNECTED TO A GROUNDING LUG EITHER IN THE SERVICE BOX OR THE MOTOR GENERATOR COMPARTMENT.

VII. INSTALLING THE OPTIONAL HEATER ACCESSORY

NOTE

The optional Heater Accessory is intended to take the chill out of the indoor air when the air is a few degrees too cool for comfort. The Heater Accessory is an effective “chill chaser”. It is not a substitute for a furnace.

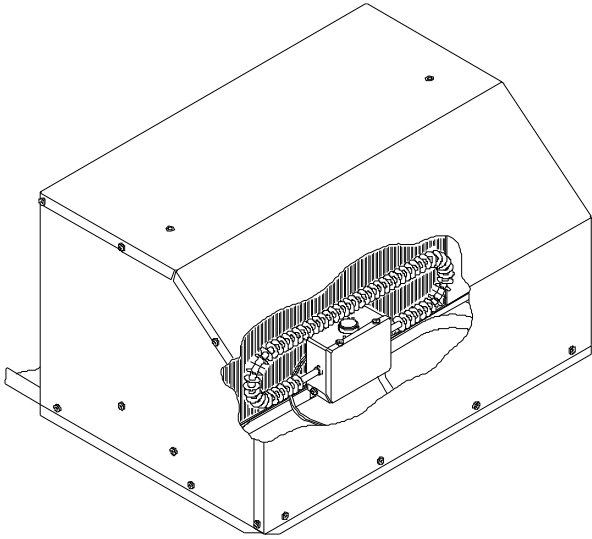

FIGURE 5

If the heater option is being installed, position the heater assembly in the air conditioner return air opening as shown in Figure 5. The heater bracket must be installed over the metal basepan extrusion and positioned between the basepan and the plastic drain pan (See Figure 6). Tighten set screw to secure the assembly so as to prevent movement. Replace the selector switch control knob on the ceiling assembly with that provided with the optional heater.

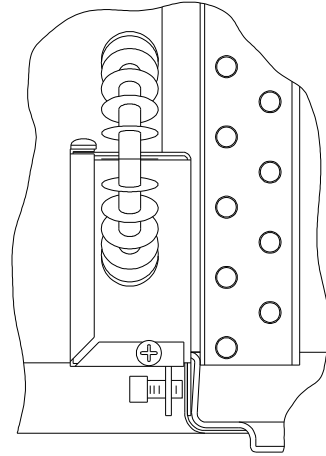

FIGURE 6

VIII. INSTALLING THE CEILING ASSEMBLY (9300 SERIES)

Make sure that you have properly matched the roof top air conditioner and interior ceiling assembly. The following step by step instructions must be performed in the following sequence to insure proper installation.

- A. Carefully uncarton the ceiling assembly. Controls are factory installed in the ceiling assembly (except ceiling assemblies for applications with remote control box/thermostat).
- B. Remove the grille and filters from the ceiling assembly.
- C. STEP “C” CAN BE SKIPPED IF THE OPTIONAL 9233(X)4551 HEATER ACCESSORY PACKAGE IS NOT INSTALLED AT THIS TIME.

Plug the heater cord into the 2 position receptacle (See Figure 7).

- D. Fasten the duct collar to the basepan of the air conditioner with three (3) screws (See Figure 9).
- E. Plug the roof top air conditioner electrical conduit into the 9 position receptacle located in the thermostat side of the ceiling assembly (See Figure 7).
- F. Insert the supply wiring through the cable clamp and into the field wiring box so that 4 - 6” of supply conductor is inside the box. Secure the cable clamp over the supply wire sheath so that no movement is possible (See Figure 8).
- G. Connect the supply power conductors to the black and white pigtail wires and the supply ground wire to the green pigtail wire found in the field wiring box using the 3 provided wire nuts. **IMPORTANT** – Connect the black supply to the black pigtail and the

TIE ALL WIRING TO INSURE NO CONTACT WITH THE HEATER OR ANY SHARP EDGES. KEEP IN MIND THAT HIGH VELOCITY AIR WILL BE ENCOUNTERED IN THIS AREA.

white supply to the white pigtail. Using a U.L. approved electrical tape, secure the wire nuts to wires in a workmanlike manner (See Figure 8).

- H. Place the metal control box shield over the thermostat, switch and field wiring boxes. Make certain that all wires are pushed into the control boxes or laying in the wireway between the thermostat and switch boxes and will not be pinched by the control box shield. Control box shield is properly installed when the two holes in the shield are aligned with the two screw holes in the ceiling assembly chute (See Figure 7).
- I. Raise the ceiling assembly and secure to the mounting frame with 4 provided shoulder screw/spring assemblies. The front two screws should pass through the clearance holes in the metal control box shield (See Figure 9).

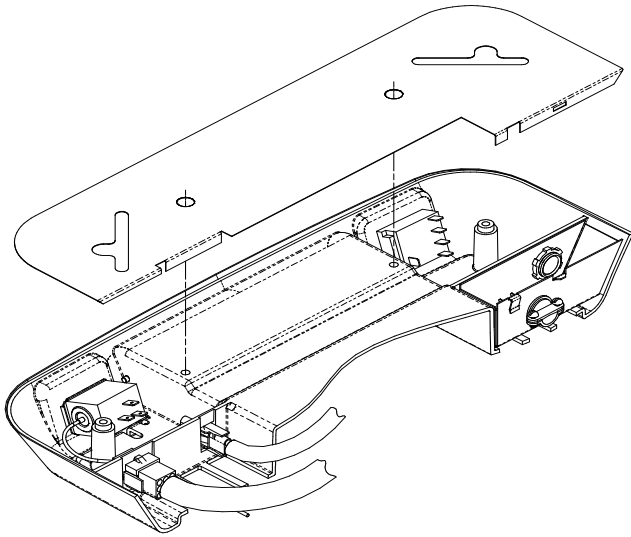

FIGURE 7

- J. The ceiling assembly shroud is curved to contour to a crowned ceiling. If installation is to a flat ceiling and gaps are present on the sides of the shroud, insert the four optional 3/4 inch screws (provided) through the mounting posts and secure them to the mounting frame above (See Figure 7, 8 & 9 for screw locations).
- K. Pull the fabric duct material through ceiling assembly discharge opening. Peel the release liner from the adhesive strip around the discharge opening. Press the fabric duct material firmly in place around opening. Cut off excess fabric on inside of ceiling assembly chute with a box knife taking care not to tear the fabric beyond the adhesive strip.
- L. Make sure the non-allergenic filters are properly positioned in the ceiling grille.
- M. Install the ceiling grille by positioning on the bottom of the shroud and engaging the two 1/4 turn fasteners.
- N. Turn the selector switch to OFF position.
- O. Turn ON the power supply to the roof top air conditioner.

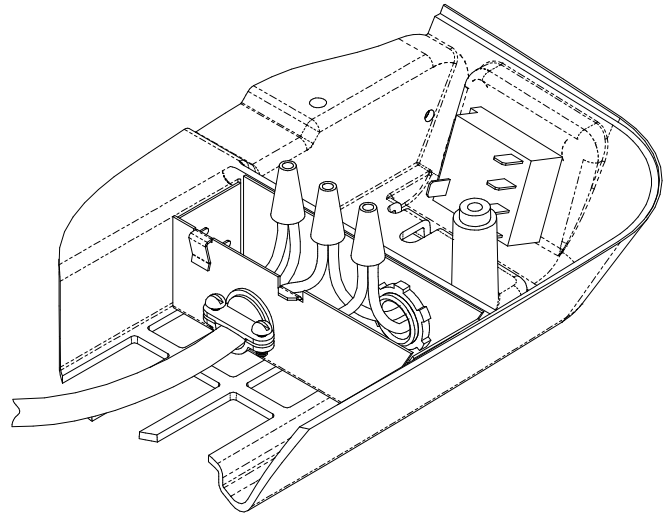

FIGURE 8

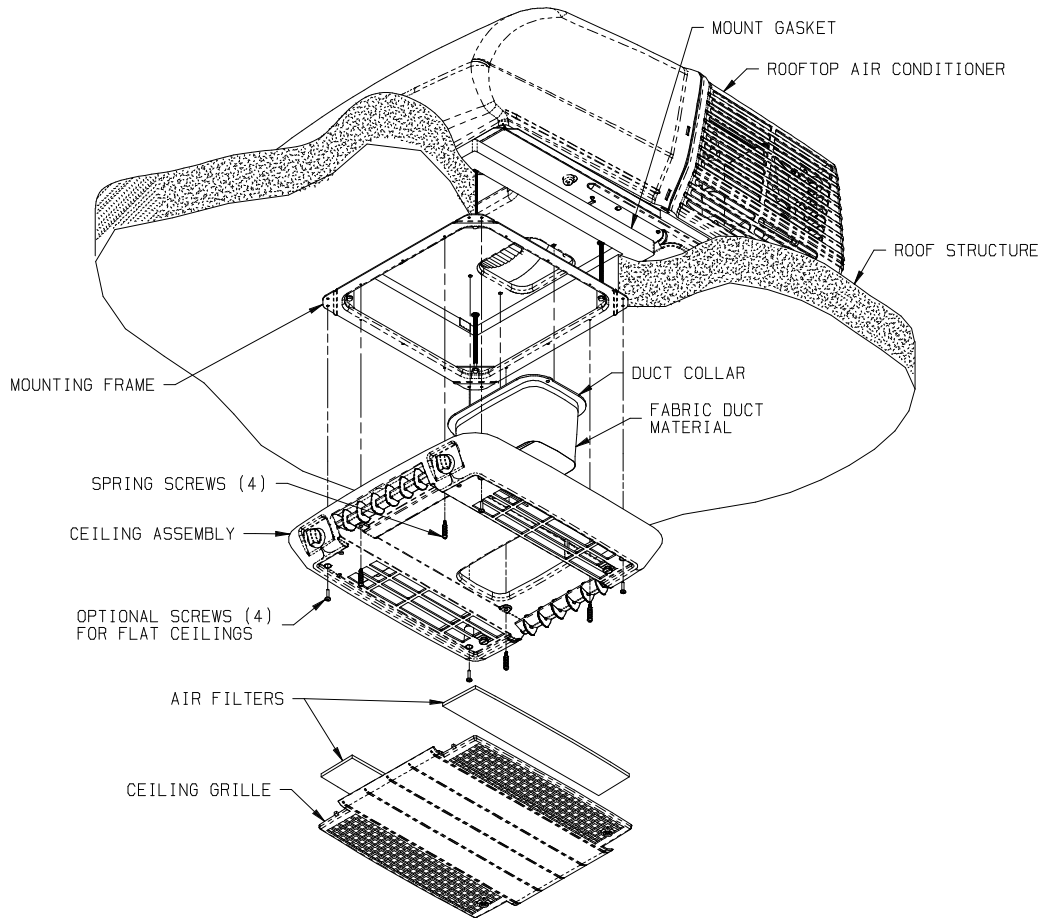

FIGURE 9

IX. INSTALLING THE CEILING ASSEMBLY (9400 SERIES)

Make sure that you have properly matched the roof top air conditioner and interior ceiling assembly. The following step-by-step instructions must be performed in the following sequence to insure proper installation.

- A. Remove ceiling assembly from carton, separate individual items and remove the two grilles and filters from the ceiling shroud.
- B. Fasten the duct collar to the air conditioner basepan with 3 provided screws (See Figure 12).
- C. Raise the ceiling assembly chute and insert the the supply wiring through the cable clamp and into the wiring box so that 4-6" of supply conductor is inside the box. Secure the cable clamp over the supply wire sheath so that no movement is possible (See Figure 10).
- D. Connect the supply power black conductor to the black pigtail wire, the white conductor to the white pigtail wire and the supply ground conductor to the green pigtail wire found in the wiring box using the 3 provided wire nuts. Using a U.L. approved electrical tape, secure the wire nuts to wires in a workmanlike manner (See Figure 11).
- E. Press supply conductors and wire nuts into wiring box and making sure no wires are pinched, secure the wire box cover with 2 provided screws (See Figure 11).
- F. Plug the air conditioner electrical conduit into the 9 position receptacle as shown in Figure 10.

- G. If the optional heater accessory package is being installed, remove the cover from the 2 position receptacle and plug the heater cord into receptacle as shown in Figure 10.
- H. Raise the ceiling assembly chute to the unit mounting frame and secure the chute with 4 provided screws (See Figure 12).
- I. **TIE ALL WIRING TO INSURE NO CONTACT WITH ANY SHARP EDGES OR WITH OPTIONAL HEATER IF POSSIBLE. KEEP IN MIND THAT HIGH VELOCITY AIR WILL BE ENCOUNTERED IN THIS AREA.**
- J. Pull the fabric duct material through the ceiling chute discharge opening. Peel the release liner from the adhesive strip around the opening. Press the fabric duct material firmly in place around opening. Cut off excess fabric on inside of ceiling chute with a box knife taking care not to tear the fabric beyond the adhesive strip.
- K. Raise the ceiling shroud and while insuring it meshes with the chute, secure to mounting frame with 4 provided screws (See Figure 12).
- L. Install the control knobs over the switch and thermostat shafts. The thermostat (temperature) control knob installs nearest the “Coleman-Mach” logo. If the optional heater accessory is installed, use the selector switch knob that was included in the heater package.
- M. Re-install the filters and grilles into the ceiling assembly shroud.
- N. Turn the selector switch to OFF position.
- O. Turn ON the power supply to the roof top air conditioner.

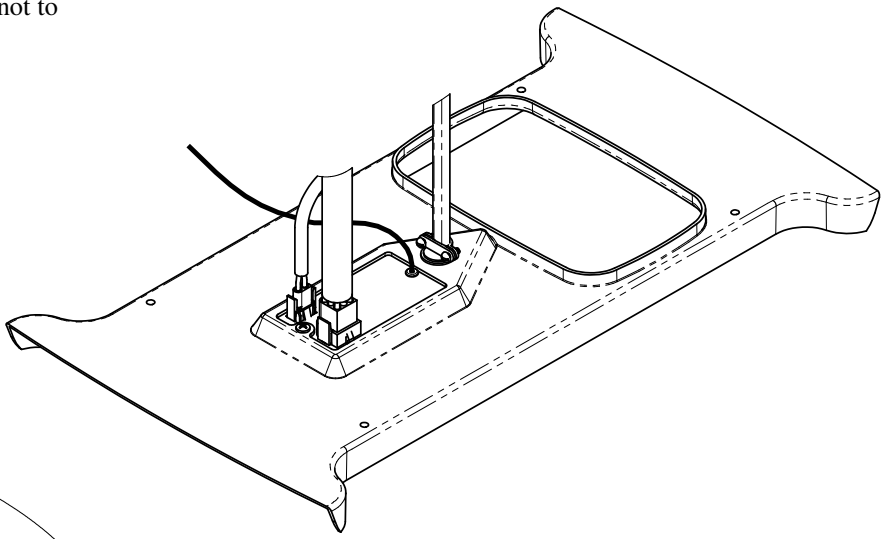

FIGURE 10

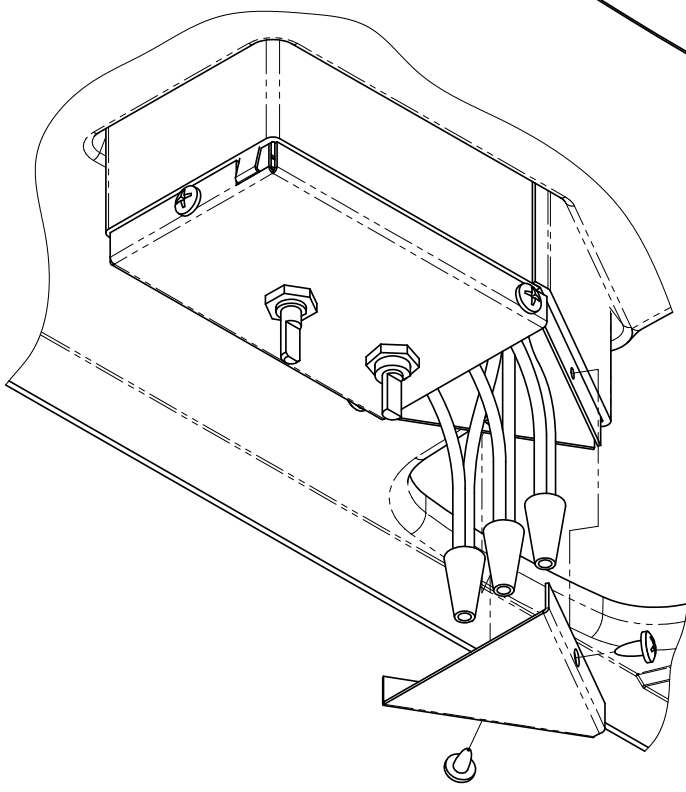

FIGURE 11

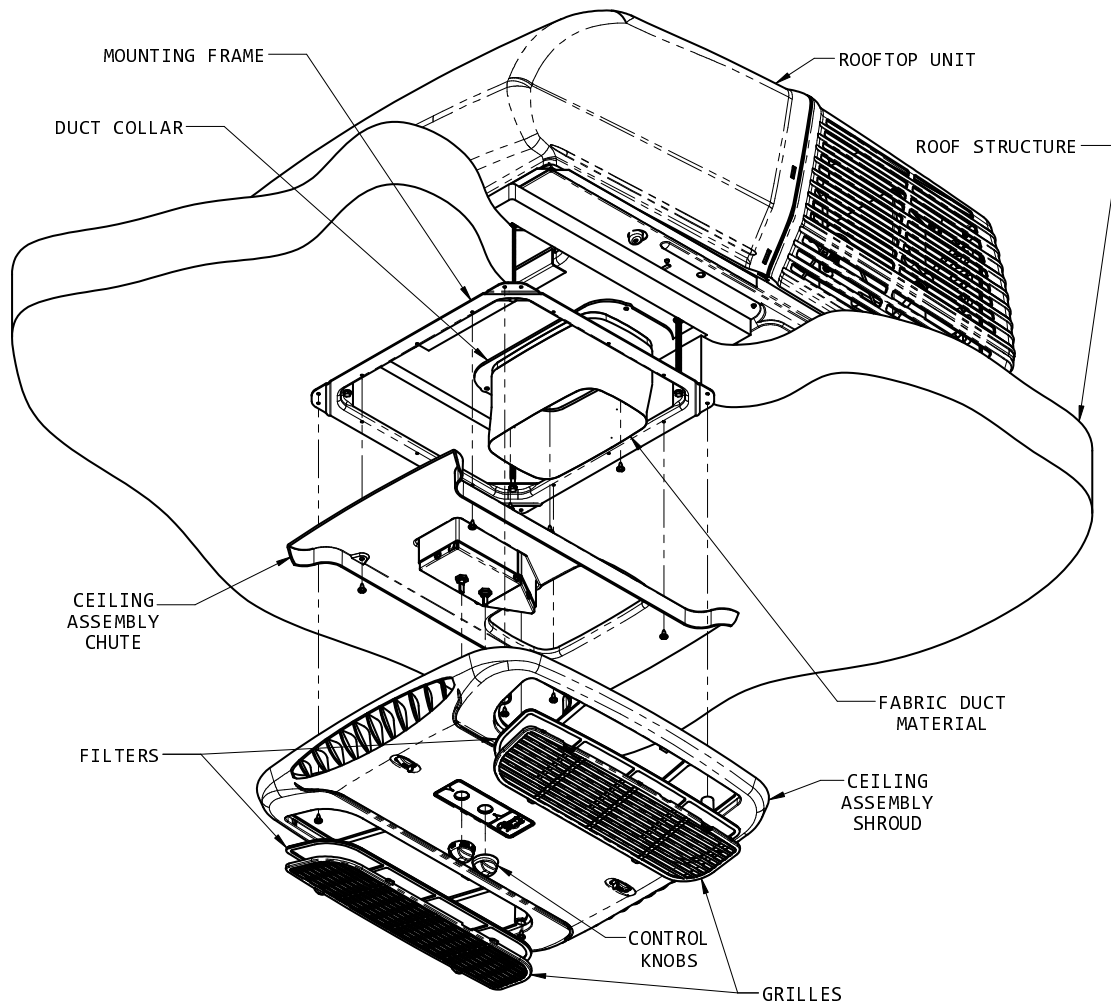

FIGURE 12

X. SYSTEM CHECKOUT

Airxcel, Inc. manufactures a wide range of roof top air conditioners which incorporate different product operation features. To properly evaluate the performance of a newly installed air conditioner,

it is necessary to review the specific unit operation characteristics (features) described in the product operation and maintenance instructions (Customer Envelope Package).



RV Products Division

**OPERATION AND MAINTENANCE INSTRUCTIONS
FOR 48000 SERIES
ROOF TOP AIR CONDITIONERS
AND
CEILING PLENUMS**

I. GENERAL INFORMATION

These air conditioners were designed to operate from a 115 VAC, 60 HZ, 1 Phase power supply. Anytime an air conditioner is not operating properly, the power supply should be examined by a qualified technician to verify that the air conditioner is receiving the proper power supply.

The ability of the air conditioner to maintain the desired inside temperature depends on the heat gain of the recreational vehicle.

The size of the vehicle, amount of window area, amount of insulation, direct exposure to the sun, outside temperature and the number of people in the recreational vehicle may increase the heat gain to such an extent that the capacity of the air conditioner is exceeded.

As a general rule, air entering the air conditioner will be cooled about 15 to 20 degrees, depending on the outside temperature and humidity conditions.

For example, if the air entering the return air grilles in the air conditioner is 80 degrees F., the air leaving the discharge grilles in the air conditioner will be 60 to 65 degrees F.

As long as this temperature difference is being maintained between the return air and discharge air, the air conditioner is operating at its capacity. If the desired inside temperature (normally 80 degrees F) cannot be maintained, then the heat gain of the RV is too great for the capacity of the air conditioner.

Parking the vehicle in a shaded area, keeping windows and doors shut and avoiding the use of heat producing appliances in the vehicle will help to reduce the heat gain. When possible, the addition of insulation and tinted glass (especially in uninsulated vans) should be considered.

NOTE

The optional Elect-A-Heat heating assembly is intended to take the chill out of the indoor air when the air is a few degrees too cool for comfort. The heating assembly is an effective “chill chaser”. It is not a substitute for a furnace.

R410A Roof Top Air Conditioners

High Pressure Switch Lockout Circuit

Air conditioners and heat pumps using R410A refrigerant utilize a factory installed High Pressure Switch Safety Circuit. In the event of an abnormal condition (failure of fan motor, dirty condenser coil, dirty filters), the high pressure switch will prevent the compressor from continuing to run. Once the high pressure switch has tripped, this safety circuit will “Lock Out” the compressor preventing it from trying to restart or run until the 115 VAC supply power has been turned off and then back on to reset the High Pressure Switch Safety Circuit. If repeated trips of the high pressure switch lock out occur, then you must have the unit serviced by a qualified technician.

II. CONTROL PANEL

If your RV air conditioner is operated from the control panel located in the ceiling assembly, then there are three controls on the ceiling assembly that help you control the air conditioner. They are as follows:

A. The Selector Switch – The selector switch determines which mode of operation the air conditioner will be in. By rotating the selector switch, the operator can obtain any system function desired. System functions vary depending upon options of both the roof top unit and ceiling assembly. Figure 1 shows selector switch location and lists all available functions by model.

The “Operation” section explains the operational characteristics of each mode of operation.

B. The Thermostat (temperature control) – In the cooling mode, the thermostat regulates the “ON” and “OFF” temperature setting at which the compressor will operate.

For “Heat/Cool” models, the thermostat also controls the “ON” and “OFF” temperature settings of the heater assembly (See Figure 1).

C. Louvers – The louvers are located at both ends of the ceiling assembly shroud and are used in directing the discharge air from the unit.

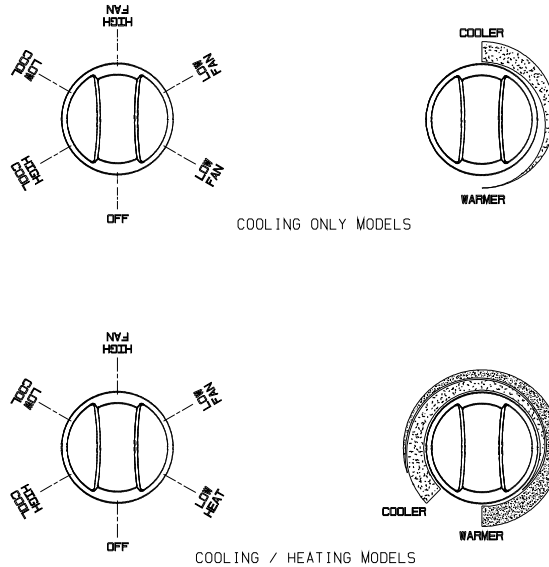
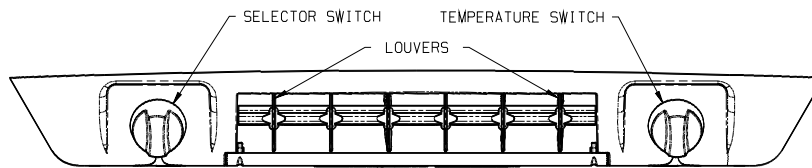

FIGURE 1

III. OPERATION

- I. **For Cooling (Refer to Figure 1, page 3).**
 - A. Turn the selector switch to the “LOW COOL” or “HIGH COOL” position.
 - B. Rotate the thermostat (temperature control) to the position that is the most comfortable to you. The thermostat will turn the compressor on when the temperature of the air entering the air conditioner rises a few degrees above the setting you have selected. Then the temperature of the air entering continues to cycle the compressor on and off in the above mentioned fashion until the selector switch is turned to another mode of operation.
 - C. Position the louvers to the desired direction the discharge air is to flow.

Note: The fan operation is constant, only the compressor cycles on the thermostat.

- II. **Operation During Cooler Nights (Cooling Operation).**

It is important, when the outdoor temperature drops in the evening or during the night to below 75 degrees F., that the thermostat (temperature control) be set at a midpoint between “Warmer” and “Cooler”. If the setting is at “Cooler”, the evaporator coil may become iced-up and stop cooling. During the day when the temperatures have risen above 75 degrees F., reset the thermostat switch to the desired setting.

NOTE

Should icing-up occur, it is necessary to let the cooling (evaporator) coil defrost before normal cooling operation is resumed. During this time, operate the unit in the “HIGH FAN” position with the system at maximum air flow. When increased or full air flow is observed, the cooling coil should be clear of ice.

III. Short Cycling

When an air conditioner is in operation, its compressor circulates refrigerant under high pressure. Once off, it will take two to three minutes for this high pressure to equalize.

The air conditioning compressor is unable to start against high pressure. Therefore, once the air conditioner is turned off, it is important to leave it off for two to three minutes before restarting.

Short cycling the compressor (or starting it before pressures have equalized), will in some instances, kick the circuit breaker or overload.

IV. For Heating (“Elect-A-Heat” Ceiling Assembly Model Only) Refer to Figure 1, page 3).

The optional Elect-A-Heat heating assembly is intended to take the chill out of the indoor air when the air is a few degrees too cool for comfort. The heating assembly is an effective “chill chaser”. It is not a substitute for a furnace.

Do not expect the heating coil on your heater to glow. Because the fan draws in cold air and forces it over the coil, the coil will not turn red. A hint of red may occur where the moving air does not directly touch the coil.

- A. Turn the selector switch to the “LOW HEAT” position. At “LOW HEAT”, the fan operates on low speed with heat output at maximum.
- B. Rotate the thermostat (temperature control) switch to the position that is the most comfortable to you. The thermostat will turn the heater on when the

temperature of the air entering the air conditioning unit drops below this setting a few degrees and automatically turns off when the temperature of the air entering the air conditioner rises a few degrees above this setting. The heater will continue to cycle on and off in this fashion until the selector switch is turned to another mode of operation.

- C. Position the louvers to the desired direction the discharge air is to flow.

Discharge air temperature can be controlled to some extent by opening or closing the louvers.

When the louvers are closed, the warmest localized discharge air is achieved. Fully opened louvers will throw the warm discharge air to the back and front of the vehicle for more efficient circulation and faster warm-up. Although the air temperature is lower with the louvers fully opened, the heating capacity is still the same.

V. For Air Circulation Only (Refer to Figure 1, page 3).

- A. Turn the selector switch to “LOW FAN” or for maximum air flow, to “HIGH FAN”.
- B. Position the louvers to the desired direction the discharge air is to flow.

NOTE

When the selector switch is in the “LOW FAN” or “HIGH FAN” position, the blower motor will operate continuously.

IV. MAINTENANCE

I. Owner

One of the biggest advantages to your new Coleman-Mach air conditioner is that the maintenance needed to keep the unit in good care is minimal. In fact about the only thing you, the owner, must take care of is the cleaning and replacement of the filters.

Filters are made from long life non-allergenic natural fibers which can be cleaned and reused, and which completely filter the circulated air when the air conditioner is in operation. If the filters are not cleaned at regular intervals, they may become partially clogged with lint, dirt, grease, etc. A clogged filter will produce a loss of air volume and may eventually cause an icing-up of the cooling (evaporator) coil.

IMPORTANT

Do not operate your air conditioner for extended periods of time without the filter installed.

An even more serious condition occurs when the air conditioner is operated without a filter. When this happens the lint, grease, etc. that are normally stopped by the filter are now accumulating in the cooling coil. This not only leads to a loss of air volume and a possible icing-up of the cooling coil, but could also result in serious damage to the operating components of the air conditioner.

We recommend that the filters be cleaned and changed at least every two weeks when the air conditioner is in operation.

Cleaning and/or changing the filters:

1. Disengage the two 1/4 –turn fasteners that secure the ceiling assembly grille to the ceiling assembly (See Figure 2).
2. Lower the grille and filters from the ceiling assembly.
3. Take filters out and either clean or exchange with other filters (See Figure 2).
4. If the vehicle is equipped with a flush mount ceiling assembly, remove the four return air grille screws. Remove filter from grille and either clean or exchange with new filters.

NOTE

If replacement filters are necessary, the filters can be purchased from most Airxcel, Inc. Authorized Service Centers. It is recommended that spare filters be carried with the RV at all times to replace worn, torn or deteriorated filters.

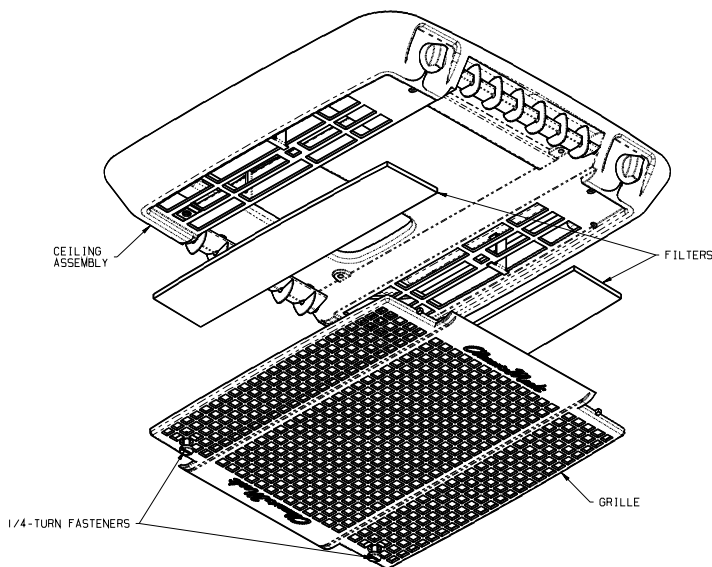

FIGURE 2

II. Service Person

- A. Electrical – All electrical work and/or inspection should be performed only by qualified service personnel. Contact your nearest Airxcel, Inc. Service Center if electrical problems should arise.
- B. Check Points – Failure to start or to cool the air are sometimes problems with air conditioning units. The Coleman-Mach RV air conditioner is designed to operate on 115 volt electrical power. If the compressor on the air conditioner fails to start, check with your Airxcel, Inc. Service Center to determine

that the proper wire size is connected to the unit, the proper circuit breakers are installed as protection devices on the electrical circuit and the proper sized extension cord is being used for the distance covered from the utility outlet to the RV. The required minimum wire size is #12 AWG for lengths up to 25 feet (larger wire size for greater distances). Each air conditioning unit must be protected with a 20 amp time delay fuse or circuit breaker.

If the air conditioner continues to trip off the circuit breakers, have an electrician check the starting amperage and running amperage on the unit. If the circuit breaker continues to trip off and the electrical consumption is found to be normal, it will require the replacement of the faulty circuit breaker.

If all electrical power to the air conditioner is normal but neither the fan or the compressor will operate, the connector plug located behind the ceiling assembly control box should be checked to determine whether it is faulty.

On the heating-cooling air conditioner models, if all electrical power to the unit is normal and the fan runs but you never get any heated air, then the electrical plug to the heating unit should be checked for a secure connection. If this does not correct the malfunction, the heating thermostat or limit switch may be faulty.

- C. Mechanical Integrity – The air conditioner should be inspected periodically to be sure that the bolts which secure the unit to the roof are tight and in good shape. Also, an examination of the plastic shroud covering the air conditioner on the top of the roof should be made periodically. Be sure the four mounting screws and washers are snug and holding the shroud to the air conditioner. Also examine the shroud to be sure it is not developing cracks or has suffered damage from impact.
- D. Lubrication

DANGER

DISCONNECT THE POWER SUPPLY TO THE UNIT BEFORE SERVICING TO PREVENT A SHOCK HAZARD OR POSSIBLE INJURY FROM MOVING PARTS.

The blower drive motor on some units may include oiling cups at the top of the motor. There is no requirement to oil the journals under normal operating conditions. However, if lubrication to the unit is desired, use only SAE 20 non-detergent type oil. DO NOT OVER OIL – three to four drops in each oil hole once a year if sufficient.