



# INSTALLATION MANUAL

## ADJUSTABLE TRAVEL'R ARMS

### AND CANOPY

RV

THIS MANUAL PROVIDES INSTRUCTIONS FOR  
ORIGINAL EQUIPMENT MANUFACTURER (OEM), AFTERMARKET INSTALLATIONS AND  
ARM UPGRADES FOR CURRENT CAREFREE AND A&E AWNINGS



#### TABLE OF CONTENTS

<b>Product Overview</b> .....	<b>1</b>
Component Checklist.....	2
<b>Installation</b> .....	<b>3</b>
Required Pre-Installation Preparation.....	3
Installing an Awning Rail.....	4
Assembling the Awning .....	5
Mounting the Awning .....	6
Switch and Wiring Installation.....	8
Securing the Fabric.....	9
Removing the Temporary Assembly Pins.....	10
Installing the Tractioners.....	10
Attaching the Fascia .....	10
<b>LED Switch Installation (Factory Installed Option)</b> .....	<b>11</b>
Wire Routing – Option 1, Standard .....	11
Wire Routing – Option 2, Motorized Awnings.....	11
Switch Installation.....	12

## PROPRIETARY STATEMENT

The Travel'r Patio Awning is a product of Carefree of Colorado, located in Broomfield, Colorado, USA. The information contained in or disclosed in this document is considered proprietary to Carefree of Colorado. Every effort has been made to ensure that the information presented in the document is accurate and complete. However, Carefree of Colorado assumes no liability for errors or for any damages that result from the use of this document.

The information contained in this manual pertains to the current configuration of the models listed on the title page. Earlier model configurations may differ from the information given. Carefree of Colorado reserves the right to cancel, change, alter or add any parts and assemblies, described in this manual, without prior notice.

Carefree of Colorado agrees to allow the reproduction of this document for use with Carefree of Colorado products only. Any other reproduction or translation of this document in whole or part is strictly prohibited without prior written approval from Carefree of Colorado.

## SAFETY INFORMATION

---

**⚠ WARNING** A WARNING INDICATES A POTENTIALLY HAZARDOUS SITUATION WHICH, IF NOT AVOIDED, COULD RESULT IN DEATH OR SERIOUS INJURY AND/OR MAJOR PROPERTY DAMAGE.

---

**⚠ CAUTION** A caution indicates a potentially hazardous situation that may cause minor to moderate personal injury and/or property damage. It may also be used to alert against unsafe practices.

**NOTE:** A note indicates further information about a product, part, or step.

*Tip:* A tip provides helpful suggestions.

### Safety Notes:

- To avoid shock hazard and/or accidental system shorting, always disconnect battery or power source before working on or around the electrical system.
- Always wear appropriate safety equipment (i.e. goggles).
- Awnings have significant weight. Always use appropriate lifting devices and/or helpers when lifting or holding heavy objects.
- When using fasteners, use care to not over tighten. Soft materials such as fiberglass and aluminum can be "stripped out" and lose the ability to grip and hold.

## PRODUCT OVERVIEW

The adjustable Travel'r provides motorized awning comfort with Carefree's standards for looks, strength and dependability. It is the successful blend of style, quality and economy.

The awning rollbar and arms are made from light weight, no-rust aluminum. The awning fabric is heavy weight vinyl.

### Travel'r Patio Awning Specifications:

<b>MAXIMUM EXTENSION:</b>		8 foot	<b>MAXIMUM LENGTH:</b>		21 feet
<b>PITCH:</b>	<b>FLAT</b>		<b>DROP:</b>	approximately 6 inches	
	<b>STEEP</b>			approximately 33 inches	
Measurement is from centerline of Awning Rail to centerline of rollbar					
<b>MOTOR:</b>		Power: 10VDC–14VDC	<b>Circuit Rating:</b> 15 amp		motor mounted in arm
<b>POWER SOURCE:</b>		Motor and controls are routed and hardwired into the vehicle's 12V system			
<b>EXTEND ACTUATION:</b>		Gas Shock			
<b>POSITION CONTROL:</b>		Motorized roll out/in			
<b>CONTROLLER:</b>		3 position, momentary ON, center OFF Switch			
<b>COLOR:</b>	<b>Frame:</b>	White, Black			
	<b>Canopy:</b>	Available in a Variety of fabrics and colors – refer to order sheet			

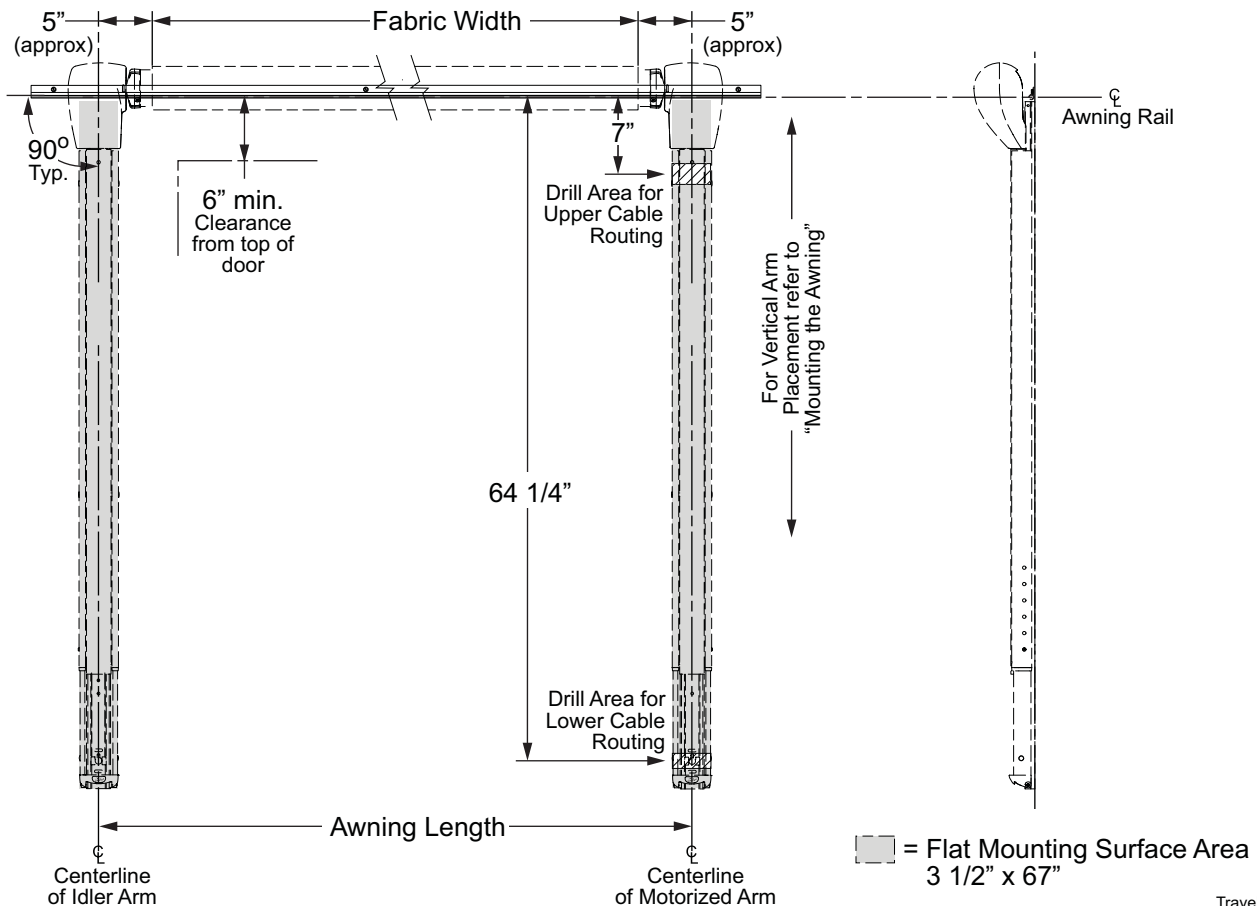

TravelR003a

COMPONENT CHECKLIST

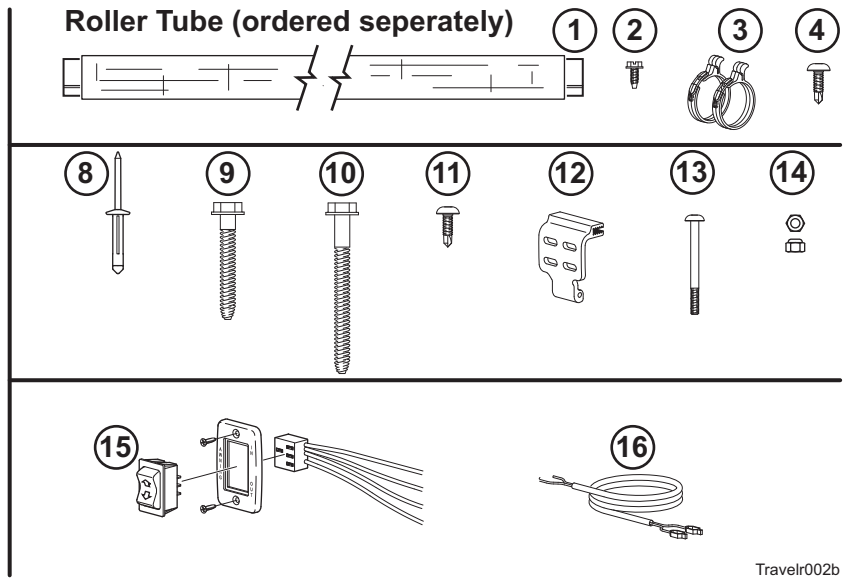
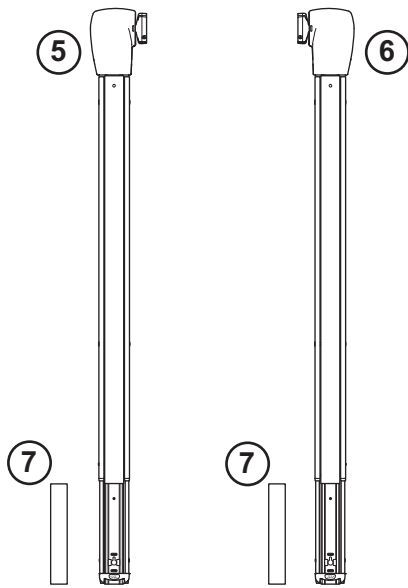

TravelR002b

☑ ITEM	DESCRIPTION	QTY		NOTE		
		A	B			
		<b>A = OEM; B = Aftermarket</b>				
<input type="checkbox"/>	1	Roller tube Assembly	1	1	Ordered Separately	
<input type="checkbox"/>	2	Screw, Hex Washer Head	2	2	#6 x 3/8	
<input type="checkbox"/>	3	Tractioner	2	2	2	
<input type="checkbox"/>	4	Screw, Truss Head, SQ Drive	2	2	2	#10 x 5/8
<input type="checkbox"/>	5	Arm Assembly, LH	1	1	1	
<input type="checkbox"/>	6	Arm Assembly, RH	1	1	1	
<input type="checkbox"/>	7	Fascia	2	2		
<input type="checkbox"/>	8	Rivet, Moly	--	10	3/16	
<input type="checkbox"/>	9	Screw, Lag	--	10	1/4 x 1 1/2	
<input type="checkbox"/>	10	Screw, Lag	--	4	1/4 x 2 1/2	
<input type="checkbox"/>	11	Screw, Truss Head, SQ Drive	4	4	#10 x 5/8	
<input type="checkbox"/>	12	Top Mounting Bracket	--	2		
<input type="checkbox"/>	13	Screw, Phillips Pan Head	--	2	#10 x 2	
<input type="checkbox"/>	14	Nylock Nut	--	2	#10	
<input type="checkbox"/>	15	Switch Kit	NOTE	1	4	
<input type="checkbox"/>	16	Jumper Cable	1	1	3	

- Notes:
1. Awning configuration is specified at time of order, including awning length, fabric, color etc. Check awning assembly against original purchase order. Arms are configuration specific and are not interchangeable.
  2. Screws and Tractioners are furnished with roller tube assemblies equipped with optional Alumaguard.
  3. Place Jumper Cable (item 16) with RV owner information.
  4. For OEMs, the Carefree switch kit is purchased separately and not included with the arms. OEM's may choose to furnish the control switch. The switch must be a DC polarity reversing switch with dynamic brake.

## INSTALLATION

### REQUIRED PRE-INSTALLATION PREPARATION

1. Park the vehicle on a flat surface and level the unit.
2. IF THIS IS AN UPGRADE FOR A MANUAL PATIO AWNING: follow the awning manufacturer's instructions and remove the awning from the coach including the roller tube and canopy.
  - a. Remove all brackets.
  - b. Plug and seal all mounting holes. The new Travel'r arms may not match the locations of the old awning arms.
  - c. Remove the roller tube from the arms and on a flat clean surface, roll the fabric onto the roller tube.
  - d. If the canopy is equipped with Alumaguard, remove the tractioners and set aside. These will be reinstalled after the new awning assembly is installed.
3. IF THIS IS AN UPGRADE FOR A ONE-TOUCH AWNING:
  - a. If the existing installation uses an external wall plug, the installer must furnish the mating plug for the new motor wires or remove the wall connector and wires. Plug and seal the hole then follow the standard wiring instructions.
  - b. Determine the existing wiring configuration:
    - *Configuration A* – Direct connection to switch. Motor wires connect directly to switch through the wall-mount connector. If the connector is retained (see step a), it is not necessary to remove the existing switch.
    - *Configuration B* – Control box electronics. A control box is installed between the connector and switches. Disconnect and remove the existing control boxes, wiring and switches. The system is replaced with the single switch control.
    - *Configuration C* – Auto Retract –All. Disconnect and remove the existing control boxes, wiring and switches. The system is replaced with the single switch control. Travel'r Direct Response Auto-Retract is available as a separate upgrade kit (SR0093) for the Travel'r Patio Awning.
  - c. Remove the awning from the coach including the roller tube and canopy.
  - d. Remove all brackets.
  - e. Plug and seal all mounting holes. The new arms may not match the locations of the old awning arms.
  - f. Remove the roller tube from the arms and on a flat clean surface, roll the fabric onto the roller tube.
  - g. If the canopy is equipped with Alumaguard, remove the tractioners and set aside. These will be reinstalled after the new awning assembly is installed.
4. For upgrades, follow the instructions for aftermarket installations.
5. Check where the awning arms will be installed. The arms fit snug to the side of the vehicle and must not cover or interfere with exhaust vents, lights etc.
6. If there is an awning rail installed, check that the awning rail runs the full length of the awning. Please refer to the note under "Installing an Awning Rail" before proceeding.
7. Refer to the important note on page 6 about the required positioning of the centerline of the roller tube.
8. For the bottom 3 mounting holes: if mounting into structure, use the 1/4 x 1 1/2 screws; if not attaching into structure, use the furnished moly rivets.

**NOTE:** The upper mounting holes (all configurations) MUST attach into structure using the screws provided.

*OEM Installations:* If structural backing is not available for the upper mounting holes, it will be necessary to use the aftermarket upper arm mounting bracket so that the upper brackets can mount into the structural members at the roof line.

## INSTALLING AN AWNING RAIL

**NOTE: For canopies WITHOUT Alumaguard or Uniguard:** If the vehicle already has a full-length awning rail installed, skip to step 5. The awning rail and arms must be positioned so that any existing trim does not interfere with the awning arm when in the closed position.

**For Alumaguard and Uniguard installations:** If the existing awning rail is incorporated into the coach trim or a drip rail, it will be necessary to mount a standard awning rail flat on the coach wall. The awning rail and arms must be positioned so that any existing trim does not interfere with the Alumaguard or Uniguard's "Flex Connect" or the awning arm when in the closed position.

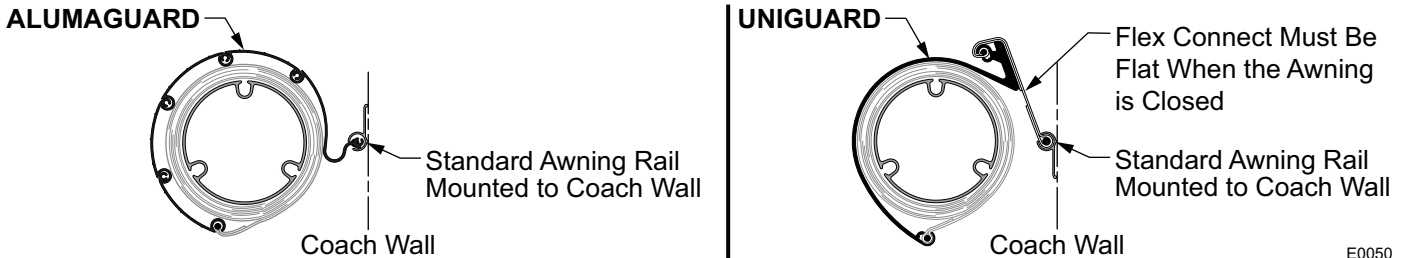

E0050

1. Determine the optimum positioning of the awning so that the arms will not interfere with the door frame or light fixtures. The centerline of the awning rail should be above the door opening a minimum of 6" for vinyl and 7" for Alumaguard/Uniguard. After determining mounting position, mark the position with a chalk line.
2. Awning rail must be level.
3. Seal the back of the rail with silicone sealant or putty tape.
4. Align the awning rail onto the wall and secure with #10 x 3/4" screws. Use all the attach holes in the rail.

**⚠ CAUTION Make sure the screws are securely mounted to the structural frame of the vehicle.**

5. Use a screwdriver to spread open one end of the awning rail on the installation side.
6. File any sharp edges or burrs from the end of the rail. This will help protect the awning fabric from damage during installation.
7. Spray inside the awning rail track with a dry silicone lubricant.

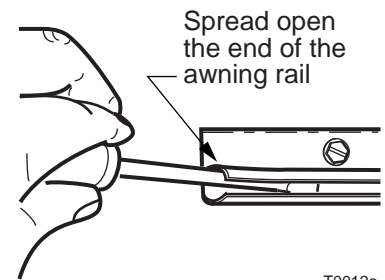

T0012a

## ASSEMBLING THE AWNING

1. Decide on the location of the switch to determine the cable routing.
2. If the motor cable is to be routed through the RV wall at the bottom of the arm, slip the cable through the slot at the bottom of the track (refer to **Error! Reference source not found.**). Go to step 4.
3. If the motor cable is to be routed through the RV wall at the top of the arm:
  - 3.1 Remove the plastic wrap at the top of the motorized arm. Partially open the arm being careful to not let the arm extend more than 6".
 

**NOTE:** The arm is under tension from the gas shock located in the arm.
  - 3.2 Pull the motor cable from the back of channel and out the hole in the top of the channel.
  - 3.3 Close the arm.
  - 3.4 Secure the top of the arm in the closed position using a plastic wrap or equivalent.

### 4. For Aftermarket and Upgrade Installations:

On each arm attach the top mounting bracket to the channel using the screw and nut as shown.

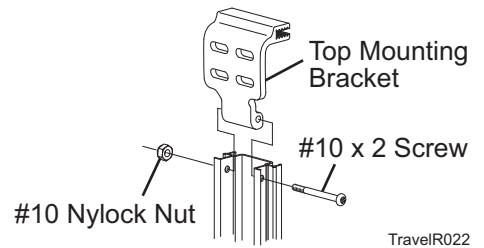

5. Align the roller assembly with the end cap on the motorized arm assembly. Rotate the end cap until the slot in the cap aligns with the empty slot in the roller assembly, and then press the roller assembly fully into the cap. The end cap must seat squarely over the end of the roller assembly when complete.

**NOTE:** The roller assembly must be oriented with the fabric going over the roller toward the mounting surface.

6. Secure the end cap to the roller assembly using two #10 square-drive screws.
7. Repeat steps 5 and 6 to attach the non-motorized arm assembly to the roller assembly.

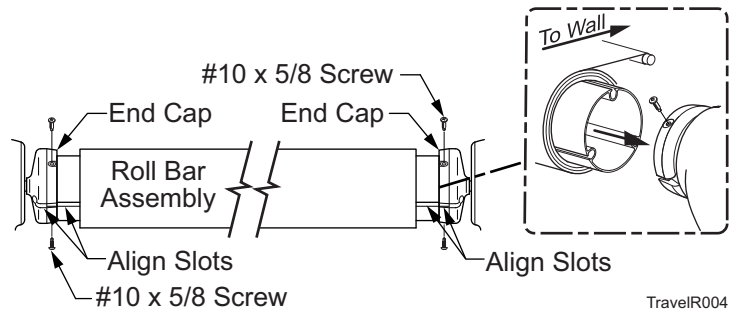

**⚠ CAUTION** During assembly and installation, The arm assemblies must remain perpendicular to the roller assembly. Failure to handle the arm assemblies carefully can bend the drive shaft.

## MOUNTING THE AWNING

**⚠ CAUTION** It is recommended that at least three people install the awning due to its size and weight.

(Refer to the General Layout on page *Error! Bookmark not defined.*)

1. Check the location the awning is to be mounted. Ensure that the awning will not interfere with other equipment on the vehicle, such as a slide out room, light fixtures, exhaust vents etc.
2. On the awning rail, mark the location of the centerline of the motorized arm assembly.
3. Unroll the canopy one wrap.

**NOTE:** While the awning fabric is fairly robust, care must be taken not to snag it on the awning rail.

4. With one person holding each arm, the third person should thread the polyrod (the plastic rod on the edge of the fabric) into the awning rail, starting at one end. Carefully move across the vehicle, gently pulling the fabric into the rail, until the awning is in the pre-determined location.
5. Position the motorized arm on the coach: Align the center of the motorized arm with the centerline marked in step 2. Butt the top of the rear channel against the awning rail as shown.

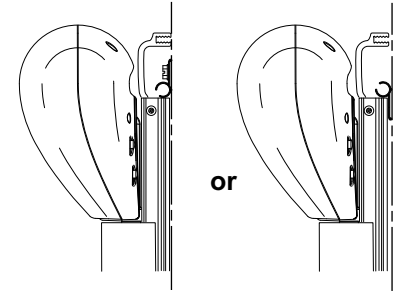

TravelR012

**IMPORTANT NOTE:** For Uniguard and Alumaguard installations, the centerline of the roller tube must be  $3/4" \pm 1/4"$  above the centerline of the awning rail. If the arm cannot be positioned as shown and meet this requirement because of trim below the awning rail, the installer must remove the trim where the arms mount or install a new awning rail below the trim.

6. Hold the arm assembly perpendicular to the awning rail and drill a  $5/32"$  hole through the #2 mounting hole and attach the motorized arm using a  $1/4 \times 1 \ 1/2"$  lag screw

**NOTE:** For the bottom 3 mounting holes: when attaching into structure, use  $1/4 \times 1 \ 1/2$  screws; if not attaching into structure, use the furnished moly rivets. Moly rivets require a  $1/4"$  hole in place of the  $5/32"$  pilot hole.

The upper mounting holes (all configurations) must be attached into structure using the screws provided.

*OEM Installations:* If structural backing is not available for the upper mounting holes, it will be necessary to use the aftermarket top brackets to attach into the structural members at the roof line.



7. Confirm that the arm is perpendicular to the awning rail, attach the arm through the #1 mounting hole (shown in **Error! Reference source not found.**) using a 5/32" pilot hole and a 1/4 x 1-1/2" lag screw.
8. Position the roller assembly so that it is perpendicular to the motorized arm assembly. Position the non-motorized arm perpendicular to the roller assembly.
9. Drill a 5/32" hole through the #2 mounting hole and attach the non-motorized arm using a 1/4 x 1 1/2" lag screw.
10. Check the alignment; the arm assembly must be perpendicular to the roller assembly. When the alignment is correct, drill and attach the arm through the #1 mounting hole (shown in **Error! Reference source not found.**) using a 5/32" drill bit and a 1/4 x 1-1/2" lag screw.
11. Hold the awning closed and carefully remove the plastic wraps at the top of the arms. The awning will open a few inches.
12. Open the awning about 18" or until the top mounting holes on the arms are visible. To open:
  - 12.1. Temporarily connect the ends of the motor wires to a 12V-14V source (i.e. drill battery). If the awning does not begin to move, reverse the leads.
  - 12.2. Remove the battery after the awning is open.

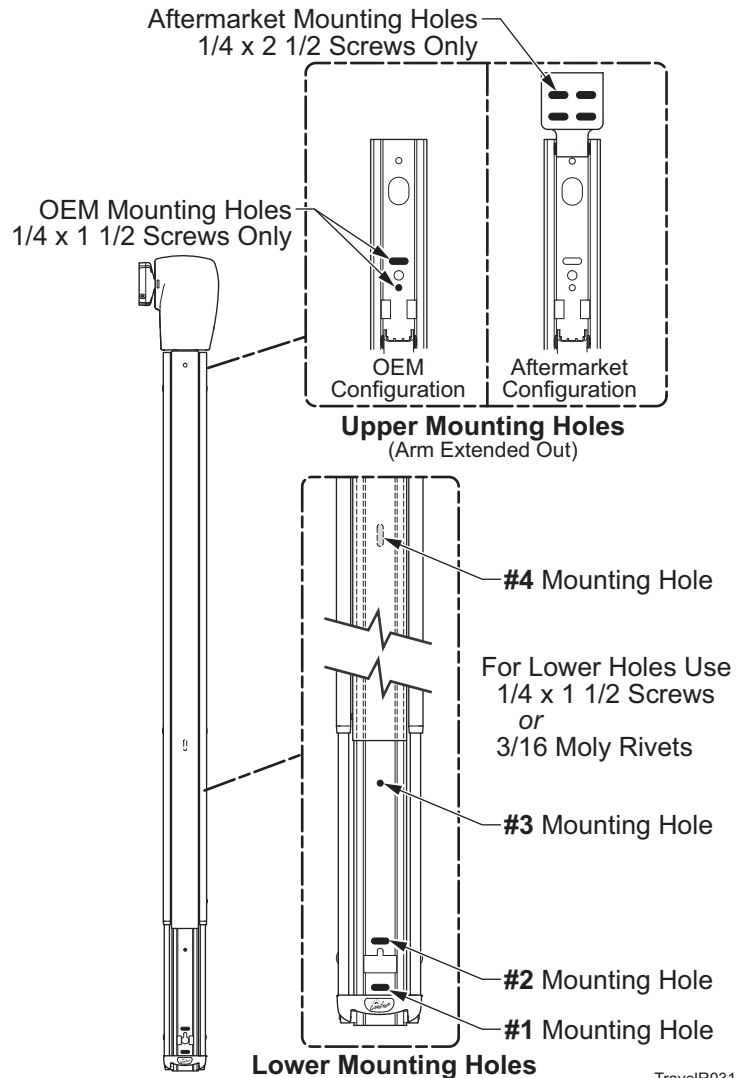

13. For Aftermarket configurations: Drill 5/32" pilot holes for the upper mounting holes through the bracket and the #3 lower mounting hole for each arm. Then attach the upper mounting bracket using 2 ea 1/4 x 2 1/2 lag screws. Attach either the #3 or #4 lower mounting hole with a 1/4 x 1 1/2 lag screw or moly rivet.
14. For OEM configurations: Drill 5/32" pilot holes for the upper mounting holes then attach using 2 ea 1/4 x 1 1/2 lag screws. Attach either the #3 or #4 lower mounting hole with a 1/4 x 1 1/2 lag screw or moly rivet.

SWITCH AND WIRING INSTALLATION

**⚠ CAUTION** Always disconnect the vehicle battery and electrical sources before working with the electrical wiring and components.

- Notes:**
1. Failure to follow the wiring instructions in this publication may void the motor warranty.
  2. DO NOT wire two or more motors to one switch—No parallel wiring.
  3. All wiring must conform to NEC (National Electrical Code) and local codes.
  4. OEM's may choose to furnish the control switch. The switch must be a DC polarity reversing switch with dynamic brake.

1. Determine the final location of the switch.

**NOTE:** If the distance from point of entry to the switch location is greater than 32" [81cm], the installer must furnish a splice between the motor cable and switch location.

2. FOR ONE-TOUCH UPGRADES:

- 2.1 If the external wall plug has been removed and sealed, go to step 3.
- 2.2 If using the wall plug, measure the motor cable from the arm to the plug. Trim the wire and terminate with an installer furnished mating connector. Attach the new connector to the wall plug and proceed to step 12.

3. For installations using the cable with a direct connection to the switch (no external plug).

- 3.1 Drill a 5/16" hole through the vehicle wall for the motor cable.
- 3.2 Route the cable through the hole to the switch location.
- 3.3 Seal the cable and hole using a silicone sealant.

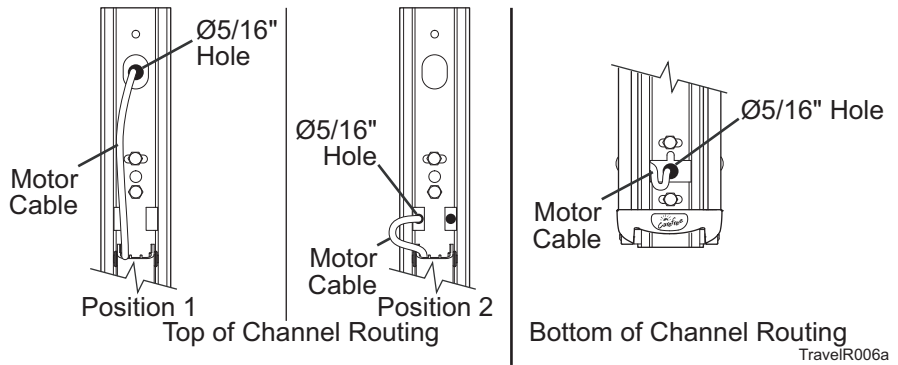

4. At the switch location, cut a rectangular hole 1.25" [3.2cm] x 1.88" [4.8cm].

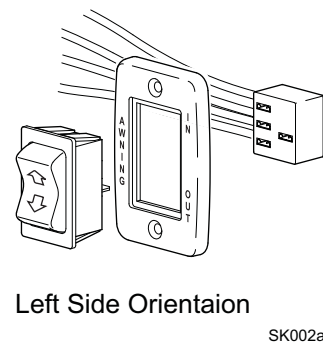
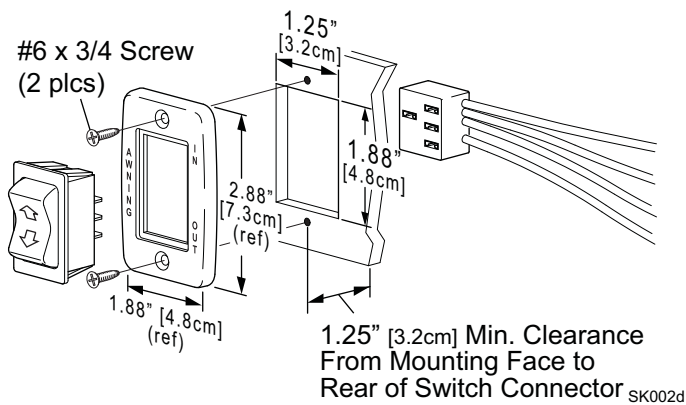

5. Determine the switch orientation:

- 5.1. The wires of the connector extend from the side of the switch with 3 terminals on the back.
- 5.2. For wire routing on the right side of the switch as shown in Details A and B, orient the switch with the 3 terminals on the right.
- 5.3. For wire routing on the left side of the switch as shown in Detail C, orient the switch with the 3 terminals on the left.
- 5.4. Push the switch into the faceplate until the tabs on the switch "click" into place behind the faceplate. Ensure that the switch and faceplate are oriented so that the lettering is up and the wires are oriented as desired.
- 5.5. Set switch aside.

6. Route the awning motor wires through the switch hole and attach to the switch connector:

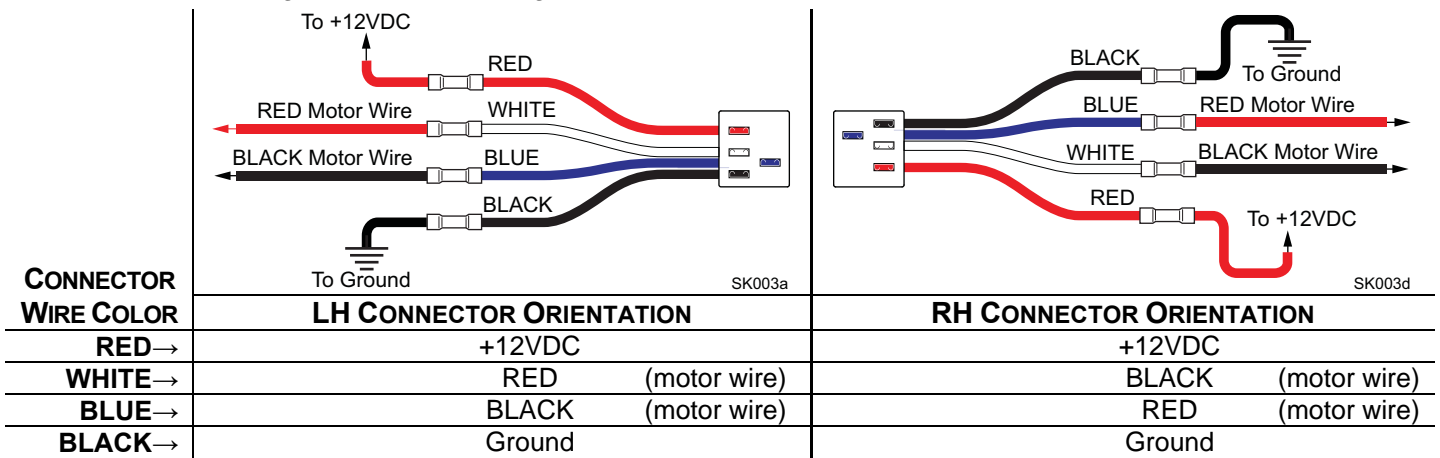

- Run a minimum 14 awg wire from the power distribution panel (auxiliary battery circuit) or equivalent. The circuit should be protected by a 15-amp fuse.
- Run a minimum 14 awg wire to system ground.
- NOTE:** If the wire run is 30 feet or longer, use 12awg wire to prevent voltage drop.
- Route the two wires through the mounting hole. Butt splice the 12VDC wire to the RED connector wire. Butt splice the ground wire to the BLACK connector wire.
- Attach the connector to the switch.
- Restore power and test the switch operation.
- If the awning operates opposite to the switch plate markings:
  - Shut off power;
  - Reverse motor wires connected to the blue and white connector wires;
  - Restore power and test.
- Push the wires, connector and switch into the mounting hole and secure the switch plate. Use two (2) #6 x 3/4" flat head screws.

**SECURING THE FABRIC**

- Roll the awning in and out several times to make sure that the fabric is square on the rollbar.
- Secure the canopy using one, #6 x 3/8" hex head screw at both sides of the awning.

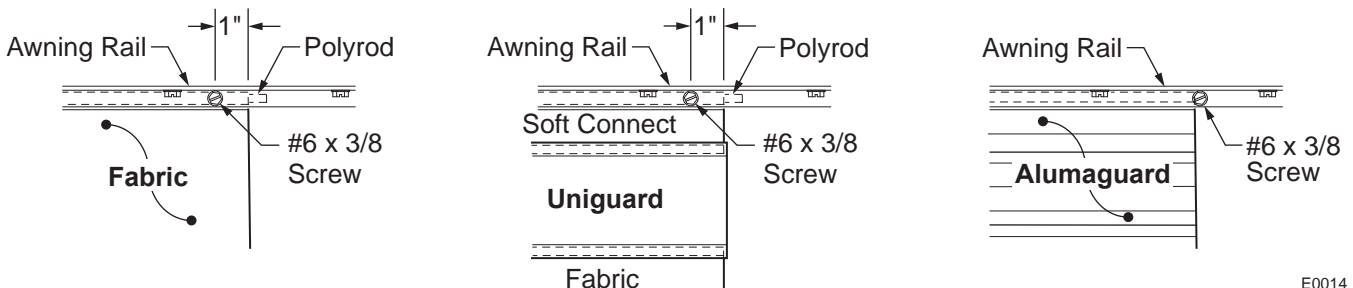

- For vinyl awnings, place screw through awning rail, polyrod and canopy approximately 1" in from the end of the fabric.
- For Uniguard awnings, place screw through awning rail, polyrod and the soft connect material approximately 1" in from the end of the fabric.
- For Alumaguard awnings, place screw on the outer edge of the Alumaguard (not through the Alumaguard).

## REMOVING THE TEMPORARY ASSEMBLY PINS

2 pins are inserted into the back of the left (idler) head for lateral stability during installation. Using a pair of pliers, remove and discard both pins.

**NOTE:** The awning will temporarily operate with the pins in place; however, for long term use the pins must be removed.

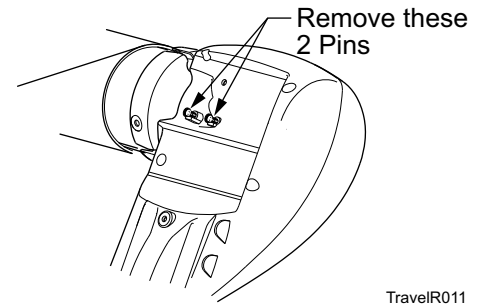

TravelR011

## INSTALLING THE TRACTIONERS

The tractioners are used with the Alumaguard and Uniguard metal fabric wraps.

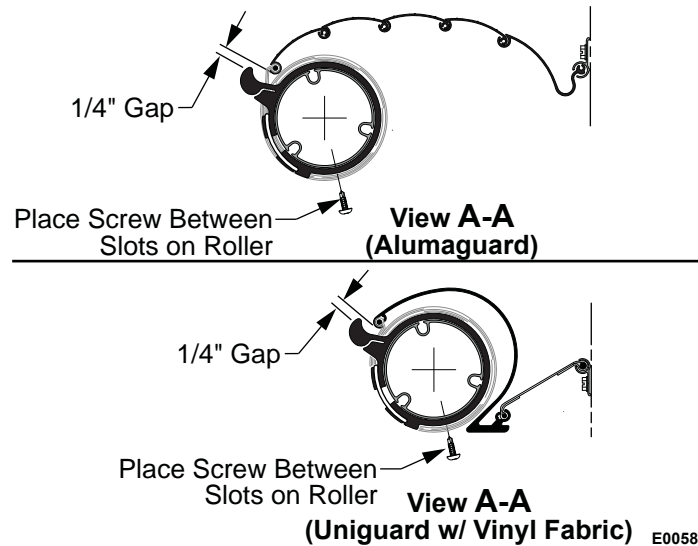
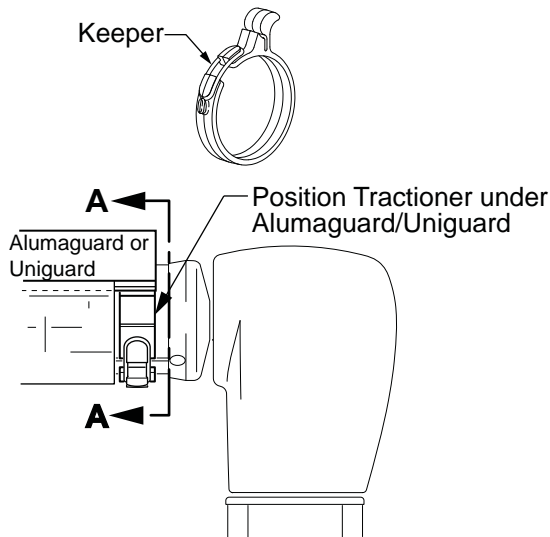

E0058

1. Partially extend the awning until the Alumaguard/Uniguard is extended as shown.
2. Unlock the keeper and wrap the tractioner around the roller tube.
3. Position the tractioner under the Alumaguard/Uniguard with a 1/4" gap between Alumaguard and tractioner. Lock the keeper.
4. Repeat for the other end of the rollbar.
5. Extend the awning to verify that the tractioners are lifting the metal wrap up and over the roller assembly.
6. To secure the tractioner, drill a 1/8" hole through the tractioner and roller tube, roughly center the hole between two slots of the rollbar.
7. Secure with one (1) #10 square drive screw.

## ATTACHING THE FASCIA

The fascia fits inside the rear channel.

1. Open the awning to provide access to the bottom of the rear channel.
2. Press the bottom dimples on the fascia into the rear channel until they snap into the bottom holes in the sides of the rear channel.
3. Press the top of the fascia into the rear channel until the upper dimples snap into the upper holes.

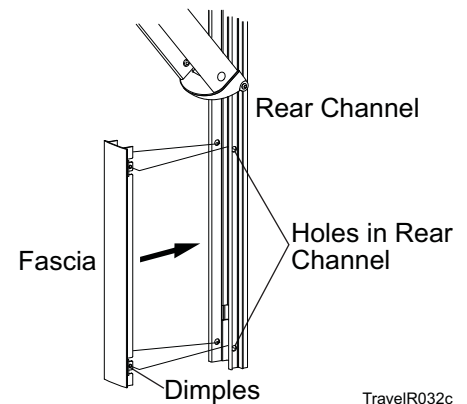

TravelR032c

## LED SWITCH INSTALLATION (FACTORY INSTALLED OPTION)

These instructions are for the optional factory installed LEDs in the roller tube. For aftermarket LED Upgrades refer to: 052593-001, White LED Upgrade or 052594-001, RGB LED Upgrade.

### SPECIFICATIONS

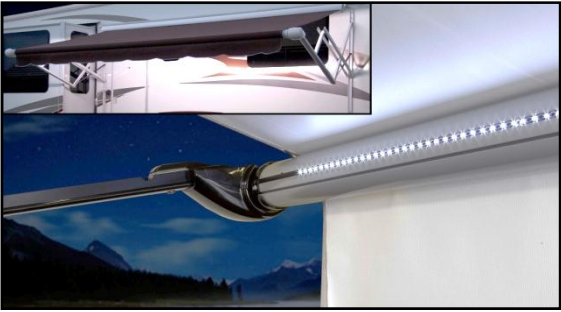
<b>MOUNTING:</b>	LED light strip is factory mounted in a specially designed roller tube. Wire is concealed in canopy hem.	 <p style="text-align: center;"><i>Shown on Carefree Eclipse Awning</i></p>
<b>LENGTH:</b>	Available for awnings 10' – 21'* * Maximum LED strip length is 16' 5". Strip is centered in roller tube for units longer than 18'	
<b>POWER:</b>	1A, 12VDC	
<b>CONTROLS:</b>	1. Single pole, single throw switch (SR0101)	
<p><i>Note: The Switch kit is ordered separately. Kit includes in-line fuse holder and 2A spade type fuse. For an installer furnished control switch, see note under "Switch Installation".</i></p>		

**NOTE:** For Travel'r and Eclipse installations, installers may choose to route the wire into the vehicle with the motor wires. Use "Wire Routing – Option 2".

### CAUTIONS:

- ⚠ The wire should be secured to the wall of the vehicle where it is exposed on the outside of the vehicle. Use a quality silicone sealant/adhesive.
- ⚠ Do not route the wire over sharp edges or heat sources that can cut or fray the wires or wire insulation.
- ⚠ Damage that is a result of improper routing may void warranty.

### Wire Routing – Option 1, Standard

1. Drill a 3/16" hole into the vehicle wall below the right edge of the canopy.
2. Route the wires from the canopy into the vehicle. Allow slack in the wire between the canopy and the wall. Seal the hole and wires with a quality silicone sealant.

### Wire Routing – Option 2, Motorized Awnings

1. After assembling the roller tube and arms per the awning instructions, route the canopy wire down the rear groove of the rear channel. Allow approximately 10 inches of cable between the canopy and arm.

**NOTE:** Cord retainers are not furnished with the awning. These may be ordered separately and used to secure the wire in the channel.

To use the retainers: Wrap the retainer around the wires. Press the retainer into the rear groove of the rear arm channel.

2. Route the wire down the rear channel groove to the desired awning motor cable entry point.
3. Route the LED wires into the vehicle with the awning motor wires.

**NOTE:** There is approximately 8 feet of wire from the wall entry point for upper wire routing, approximately 3 feet of wire from the wall entry point for lower wire routing. Controls should be located within this distance.

4. After the awning has been installed on the vehicle, route the wires along the bottom of the awning rail and secure.

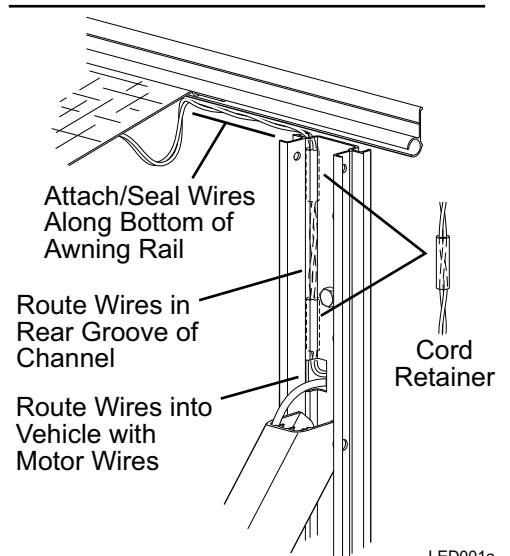
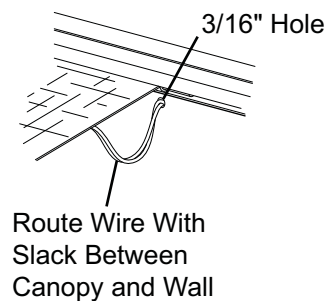

LED001a

SWITCH INSTALLATION

**NOTE:** Installers may choose to furnish the control switch. The installation requires that the power line (+12VDC) be attached to a dedicated 2A circuit breaker or a 2A in-line fuse must be installed between the switch and power source. Location of the fuse should be close to the switch for easy access.

1. Determine the location of the switch.
2. At the switch location, cut a 1 1/8" x 1 1/2" hole.
3. Wire the switch as shown below. Wire terminals at the switch are .187, 18-24 awg female disconnects.

**NOTE:** Allow adequate slack in the 12VDC power line so that the in-line fuse (installed in step 4) can be accessed from behind the switch.

4. Install the in-line fuse:
  - 4.1. Near the switch, cut the red 12VDC power line to the switch. Do not strip the insulation.
  - 4.2. Insert a wire end into one of the wire channels until it butts up against the stop.
  - 4.3. Fold that half of the connector body over until the element contacts the wire. Use pliers to crimp the connector closed.
  - 4.4. Repeat for the second wire end.
  - 4.5. Slide the fuse into the fuse port. Ensure that is firmly seated.

5. Press the in-line fuse, wires and switch into the mounting hole. Secure the switch using two (2) #6 x 1/2" screws.
6. Snap the switch bezel over the switch frame.

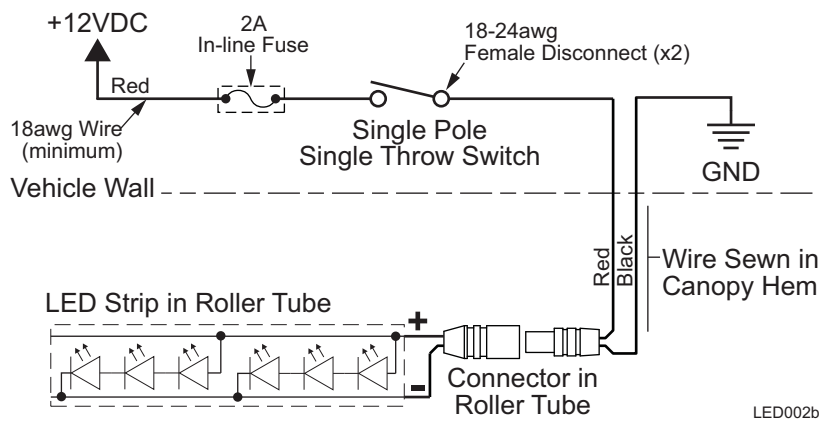
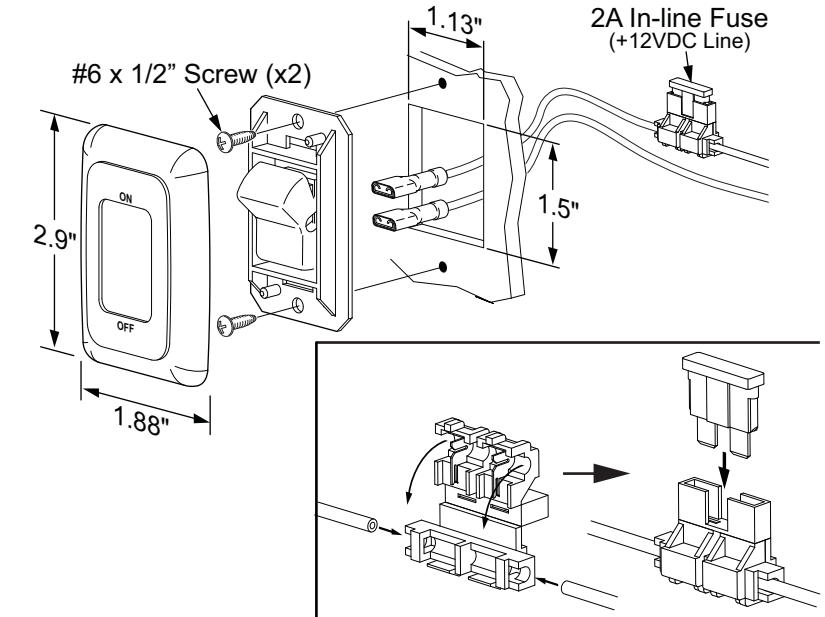

LED002b



INSTALLATION MANUAL  
ADJUSTABLE TRAVEL'R ARMS  
AND CANOPY

RV

WITH DIRECT RESPONSE

*The Adjustable Pitch Travel'r with Direct Response is an OEM option only.*



## PROPRIETARY STATEMENT

The Travel'r Patio Awning is a product of Carefree of Colorado, located in Broomfield, Colorado, USA. The information contained in or disclosed in this document is considered proprietary to Carefree of Colorado. Every effort has been made to ensure that the information presented in the document is accurate and complete. However, Carefree of Colorado assumes no liability for errors or for any damages that result from the use of this document.

The information contained in this manual pertains to the current configuration of the models listed on the title page. Earlier model configurations may differ from the information given. Carefree of Colorado reserves the right to cancel, change, alter or add any parts and assemblies, described in this manual, without prior notice.

Carefree of Colorado agrees to allow the reproduction of this document for use with Carefree of Colorado products only. Any other reproduction or translation of this document in whole or part is strictly prohibited without prior written approval from Carefree of Colorado.

## SAFETY INFORMATION

---

**⚠ WARNING** A WARNING INDICATES A POTENTIALLY HAZARDOUS SITUATION WHICH, IF NOT AVOIDED, COULD RESULT IN DEATH OR SERIOUS INJURY AND/OR MAJOR PROPERTY DAMAGE.

---

**⚠ CAUTION** A caution indicates a potentially hazardous situation that may cause minor to moderate personal injury and/or property damage. It may also be used to alert against unsafe practices.

**NOTE:** A note indicates further information about a product, part, or step.

*Tip:* A tip provides helpful suggestions.

### Safety Notes:

- To avoid shock hazard and/or accidental system shorting, always disconnect battery or power source before working on or around the electrical system.
- Always wear appropriate safety equipment (i.e. goggles).
- Awnings have significant weight. Always use appropriate lifting devices and/or helpers when lifting or holding heavy objects.
- When using fasteners, use care to not over tighten. Soft materials such as fiberglass and aluminum can be "stripped out" and lose the ability to grip and hold.



## PRODUCT OVERVIEW

The adjustable Travel'r provides motorized awning comfort with Carefree's standards for looks, strength and dependability. It is the successful blend of style, quality and economy.

The awning rollbar and arms are made from light weight, no-rust aluminum. The awning fabric is heavy weight vinyl.

### Travel'r Patio Awning Specifications:

<b>MAXIMUM EXTENSION:</b>		8 foot	<b>MAXIMUM LENGTH:</b>		21 feet
<b>PITCH:</b>	<b>FLAT</b>		<b>DROP:</b>	approximately 6 inches	
	<b>STEEP</b>			approximately 33 inches	
Measurement is from centerline of Awning Rail to centerline of roller tube					
<b>MOTOR:</b>		Power: 10VDC-14VDC	<b>Circuit Rating:</b> 15 amp		motor mounted in arm
<b>POWER SOURCE:</b>		Motor and controls are routed and hardwired into the vehicle's 12V system			
<b>EXTEND ACTUATION:</b>		Gas Shock			
<b>POSITION CONTROL:</b>		Motorized roll out/in			
<b>CONTROLLER:</b>		Carefree Direct Response			
<b>COLOR:</b>	<b>Frame:</b>	White, Black			
	<b>Canopy:</b>	Available in a Variety of fabrics and colors – refer to order sheet			

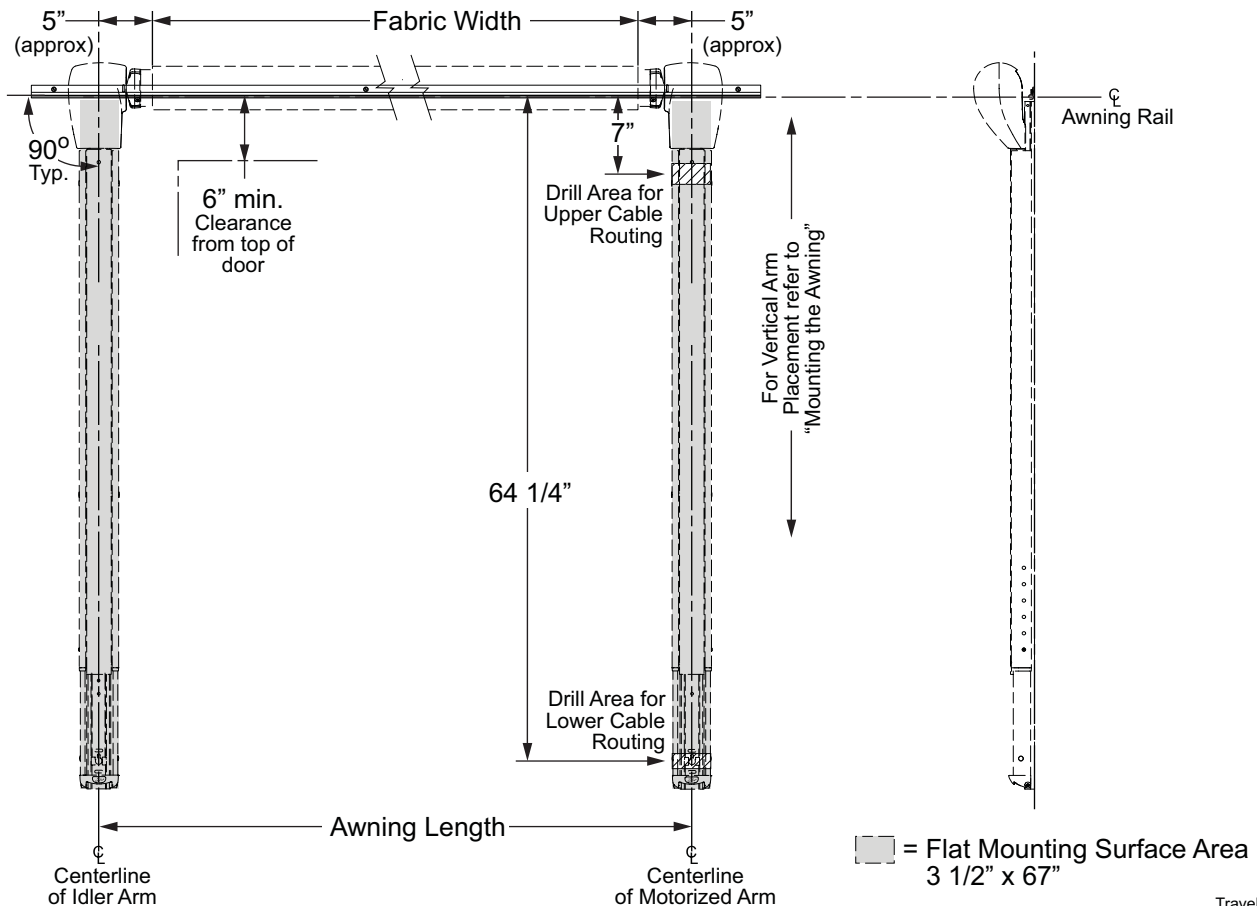

COMPONENT CHECKLIST

Roller Tube (ordered seperately)

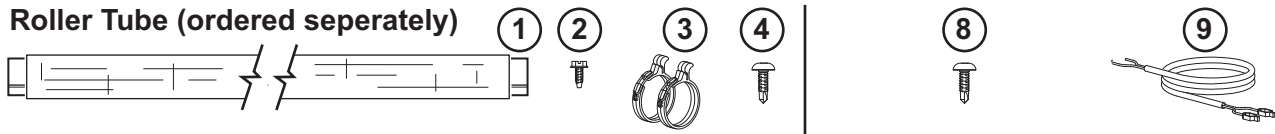

Arms

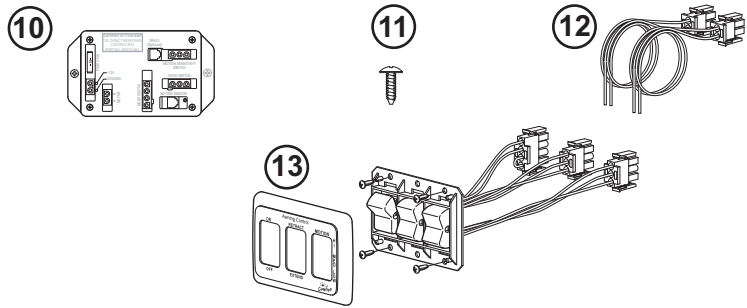
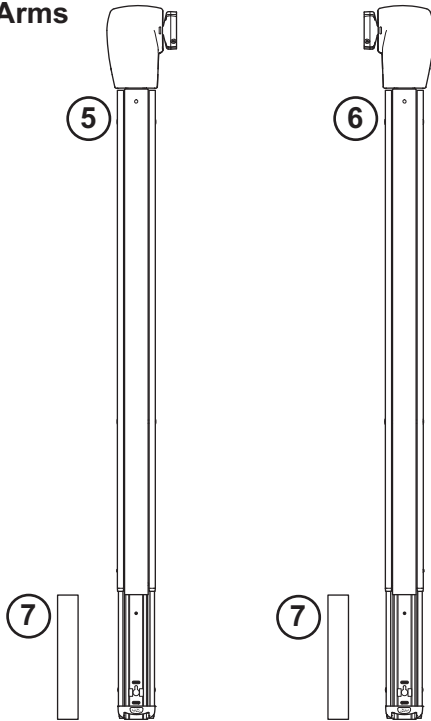

Remote Control Kit (Optional)

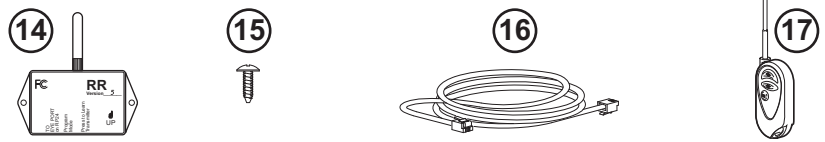

Ignition Lock-Out Kit (Optional)



Travelr002c

<input checked="" type="checkbox"/>	ITEM	DESCRIPTION	QTY	NOTE
<input type="checkbox"/>	1	Roller tube Assembly	1	Ordered Separately
<input type="checkbox"/>	2	Screw, Hex Washer Head	2	#6 x 3/8
<input type="checkbox"/>	3	Tractioner	2	2
<input type="checkbox"/>	4	Screw, Truss Head, SQ Drive	2	#10 x 5/8
<input type="checkbox"/>	5	Arm Assembly, LH	1	1
<input type="checkbox"/>	6	Arm Assembly, RH	1	1
<input type="checkbox"/>	7	Fascia	2	
<input type="checkbox"/>	8	Screw, Truss Head, SQ Drive	4	#10 x 5/8
<input type="checkbox"/>	9	Jumper Cable	1	3
<input type="checkbox"/>	10	Control Box, Direct Response	1	
<input type="checkbox"/>	11	Screw, Phillips Truss Head	2	#6 x 1/2
<input type="checkbox"/>	12	Harness, Power, Motor	2	
<input type="checkbox"/>	13	Switch Kit, Direct Response	1	(includes bezel and connector harnesses)
<input type="checkbox"/>	14	Receiver, RF, 433 MHz	1	
<input type="checkbox"/>	15	Screw, Phillips Truss Head	2	#6 x 1/2
<input type="checkbox"/>	16	Cable	1	60"
<input type="checkbox"/>	17	Remote Control Key FOB, 433MHz	1	
<input type="checkbox"/>	18	Cable	2	60"
<input type="checkbox"/>	19	Sensor, Ignition Lock-Out	1	
<input type="checkbox"/>	20	Splitter	1	

Notes: 1. Awning configuration is specified at time of order, including awning length, fabric, color etc. Check awning assembly against original purchase order. Arms are configuration specific and are not interchangeable.  
 2. Screws and Tractioners are furnished with roller tube assemblies equipped with optional Alumaguard.  
 3. Place Jumper Cable (item 9) with RV owner information.

## INSTALLATION

### REQUIRED PRE-INSTALLATION PREPARATION

1. Park the vehicle on a flat surface and level the unit.
2. Check where the awning arms will be installed. The arms fit snug to the side of the vehicle and must not cover or interfere with exhaust vents, lights etc.
3. If there is an awning rail installed, check that the awning rail runs the full length of the awning. Please refer to the note under "Installing an Awning Rail" before proceeding.
4. Refer to the important note on page 5 about the required positioning of the centerline of the roller tube.
5. For the bottom 3 mounting holes: if mounting into structure, use the 1/4 x 1 1/2 screws; if not attaching into structure, use the furnished moly rivets.

**NOTE: The upper mounting holes (all configurations) MUST attach into vehicle structure**

### INSTALLING AN AWNING RAIL

**NOTE: For canopies WITHOUT Alumaguard or Uniguard:** If the vehicle already has a full-length awning rail installed, skip to step 5. The awning rail and arms must be positioned so that any existing trim does not interfere with the awning arm when in the closed position.

**For Alumaguard and Uniguard installations:** If the existing awning rail is incorporated into the coach trim or a drip rail, it will be necessary to mount a standard awning rail flat on the coach wall. The awning rail and arms must be positioned so that any existing trim does not interfere with the Alumaguard or Uniguard's "Flex Connect" or the awning arm when in the closed position.

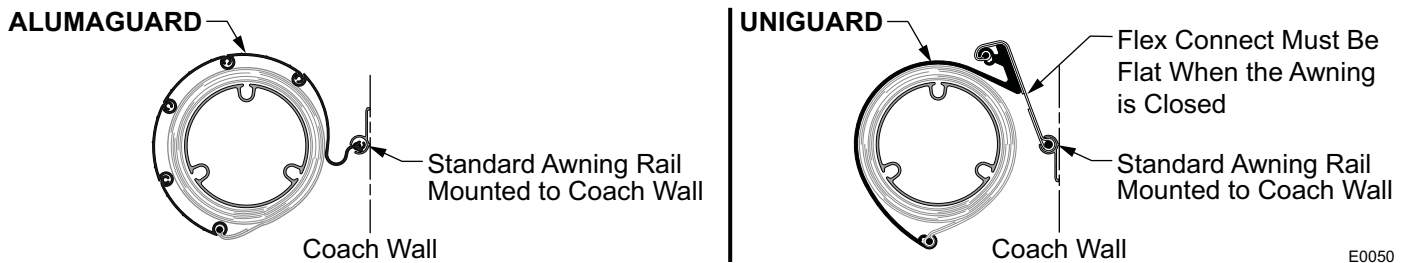

E0050

1. Determine the optimum positioning of the awning so that the arms will not interfere with the door frame or light fixtures. The centerline of the awning rail should be above the door opening a minimum of 6" for vinyl and 7" for Alumaguard/Uniguard. After determining mounting position, mark the position with a chalk line.
2. Awning rail must be level.
3. Seal the back of the rail with silicone sealant or putty tape.
4. Align the awning rail onto the wall and secure with #10 x 3/4" screws. Use all the attach holes in the rail.

**⚠ CAUTION Make sure the screws are securely mounted to the structural frame of the vehicle.**

5. Use a screwdriver to spread open one end of the awning rail on the installation side.
6. File any sharp edges or burrs from the end of the rail. This will help protect the awning fabric from damage during installation.
7. Spray inside the awning rail track with a dry silicone lubricant.

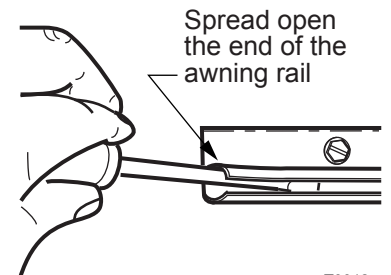

T0012a

## ASSEMBLING THE AWNING

**Important Note:** If using the optional wall spacers for the awning, follow the spacer supplement directions for assembling and mounting the awning. After mounting the awning, go to page 7 "Direct Response Installation".

1. Decide on the location of the switches and control box to determine the cable routing.
2. If the motor cable is to be routed through the RV wall at the bottom of the arm, slip the cable through the slot at the bottom of the track (refer to 7). Go to step 4.
3. If the motor cable is to be routed through the RV wall at the top of the arm:
  - 3.1 Remove the plastic wrap at the top of the motorized arm. Partially open the arm being careful to not let the arm extend more than 6".

**⚠ CAUTION** The arm is under tension from the gas shock located in the arm. When the wrap is removed, the arm will try to open completely. Firmly hold the arms closed while removing the wrap.

- 3.2 Pull the motor cable from the back of channel and out the hole in the top of the channel.
  - 3.3 Close the arm.
  - 3.4 Secure the top of the arm in the closed position using a plastic wrap or equivalent.
4. Align the roller assembly with the end cap on the motorized arm assembly. Rotate the end cap until the slot in the cap aligns with the empty slot in the roller assembly, and then press the roller assembly fully into the cap. The end cap must seat squarely over the end of the roller assembly when complete.

**NOTE:** The roller assembly must be oriented with the fabric going over the roller toward the mounting surface.

5. Secure the end cap to the roller assembly using two #10 square-drive screws.
6. Repeat steps 5 and 6 to attach the non-motorized arm assembly to the roller assembly.

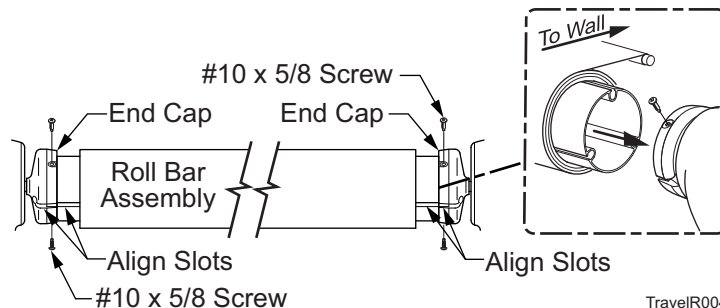

Figure 1. Assembling the Awning.

**⚠ CAUTION** During assembly and installation, The arm assemblies must remain perpendicular to the roller assembly. Failure to handle the arm assemblies carefully can bend the drive shaft.

## MOUNTING THE AWNING

If mounting an awning with the double wall spacer, refer to supplement 052540-113 for mounting instructions.

**⚠ CAUTION** It is recommended that at least three people install the awning due to its size and weight.

(Refer to the General Layout on page 1.)

1. Check the location the awning is to be mounted. Ensure that the awning will not interfere with other equipment on the vehicle, such as a slide out room, light fixtures, exhaust vents etc.
2. On the awning rail, mark the location of the centerline of the motorized arm assembly.
3. Unroll the canopy one wrap.

**NOTE:** While the awning fabric is fairly robust, care must be taken not to snag it on the awning rail.

4. With one person holding each arm, the third person should thread the polyrod (the plastic rod on the edge of the fabric) into the awning rail, starting at one end. Carefully move across the vehicle, gently pulling the fabric into the rail, until the awning is in the pre-determined location.
5. Position the motorized arm on the coach: Align the center of the motorized arm with the centerline marked in step 2. Butt the top of the rear channel against the awning rail as shown in Figure 2.

**IMPORTANT NOTE:** For Uniguard and Alumaguard installations, the centerline of the roller tube must be  $3/4" \pm 1/4"$  above the centerline of the awning rail. If the arm cannot be positioned as shown and meet this requirement because of trim below the awning rail, the installer must remove the trim where the arms mount or install a new awning rail below the trim.

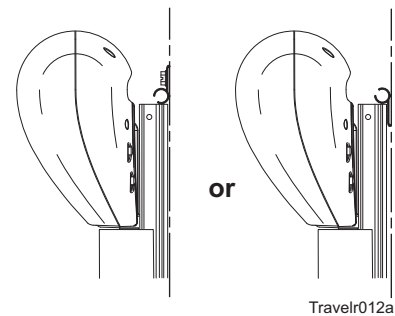

**Figure 2. Vertical Arm Positioning.**

6. Hold the arm assembly perpendicular to the awning rail and drill a  $5/32"$  hole through the #2 mounting hole and attach the motorized arm using a  $1/4 \times 1 \ 1/2"$  lag screw

**NOTE:** For the bottom 3 mounting holes: when attaching into structure, use  $1/4 \times 1 \ 1/2"$  screws; if not attaching into structure, the use of moly rivets is acceptable. Moly rivets require a  $1/4"$  hole in place of the  $5/32"$  pilot hole.

The upper mounting holes (all configurations) must be attached into structure using appropriate length  $1/4"$  screws.

7. Confirm that the arm is perpendicular to the awning rail, attach the arm through the #1 mounting hole using a 5/32" pilot hole and a 1/4 x 1-1/2" lag screw.
8. Position the roller assembly so that it is perpendicular to the motorized arm assembly. Position the non-motorized arm perpendicular to the roller assembly.
9. Drill a 5/32" hole through the #2 mounting hole and attach the non-motorized arm using a 1/4 x 1 1/2" lag screw.
10. Check the alignment; the arm assembly must be perpendicular to the roller assembly. When the alignment is correct, drill and attach the arm through the #1 mounting hole using a 5/32" drill bit and a 1/4 x 1-1/2" lag screw.
11. Hold the awning closed and carefully remove the plastic wraps at the top of the arms. The awning will open a few inches.
12. Open the awning about 18" or until the top mounting holes on the arms are visible. To open:
  - 12.1. Temporarily connect the ends of the motor wires to a 12V-14V source (i.e. drill battery). If the awning does not begin to move, reverse the leads.
  - 12.2. Remove the battery after the awning is open.
13. Drill 5/32" pilot holes for the upper mounting holes then attach using 2 ea 1/4 x 1 1/2 lag screws.
14. Attach either the #3 or #4 lower mounting hole with a 1/4 x 1 1/2 lag screw or moly rivet.

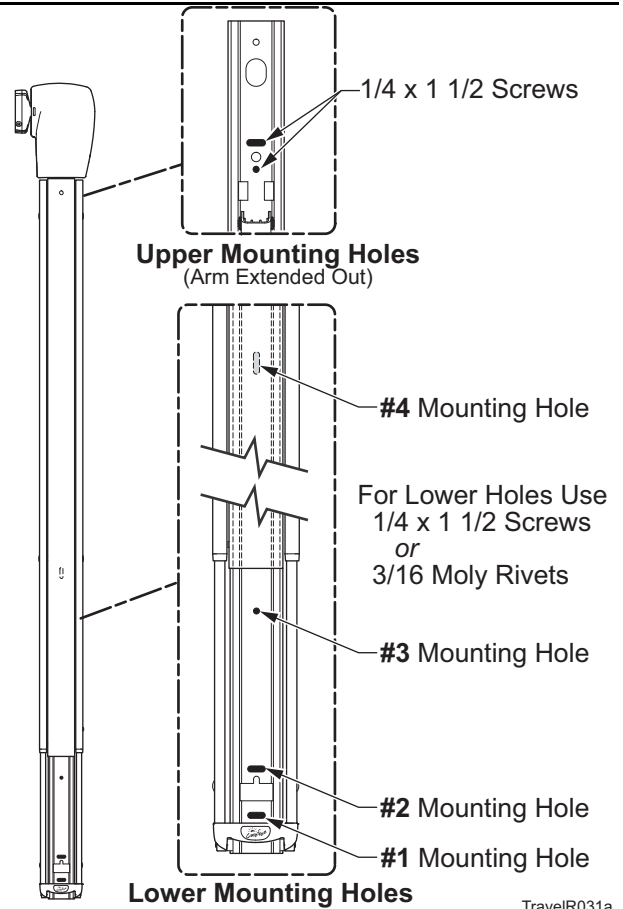

TravelR031a

## DIRECT RESPONSE INSTALLATION

**⚠ WARNING** TO AVOID SHOCK HAZARD AND/OR ACCIDENTAL SYSTEM SHORTING, ALWAYS DISCONNECT THE VEHICLE BATTERY AND ELECTRICAL SOURCES BEFORE WORKING WITH ELECTRICAL WIRING AND COMPONENTS.

**IMPORTANT NOTICES:**

- Failure to follow the wiring instructions in this publication may void the warranty.
- DO NOT wire two or more motors to one motor controller.
- All wiring must conform to NEC (National Electrical Code) and local codes.

*Routing the Wire into the Vehicle*

1. Determine the final layout of the switches and the control box and mark the locations.
2. Drill a 1/2" hole through the outside wall of the vehicle.
3. Route the sensor cable and motor wires through the hole and into the vehicle.

*Tip: Insert the sensor cable connector through the hole first then insert the motor cable.*

4. Seal the cables and holes using a silicone sealant.

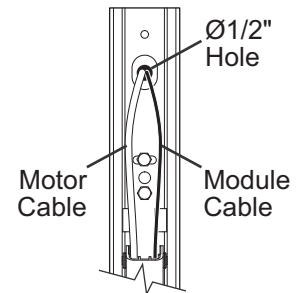

Top of Channel Routing

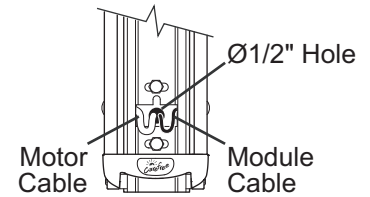

Bottom of Channel Routing

TravelR006b

*Installing the Switches*

1. At the switch location cut a 3.5" [8.9cm] x 1.5" [3.8cm] hole
2. Push the wires and switches into the hole then attach the switch frame using four (4) #6 x 1/2" screws.

**⚠ CAUTION** Ensure that the switches are oriented with the ON/OFF switch on the left to match the faceplate labels for the switch identification and orientation.

*Tip: Drilling a small pilot hole for the screws will reduce the chance of splitting or stripping out the holes in the mounting surface.*

3. Press the face plate onto the switch frame.

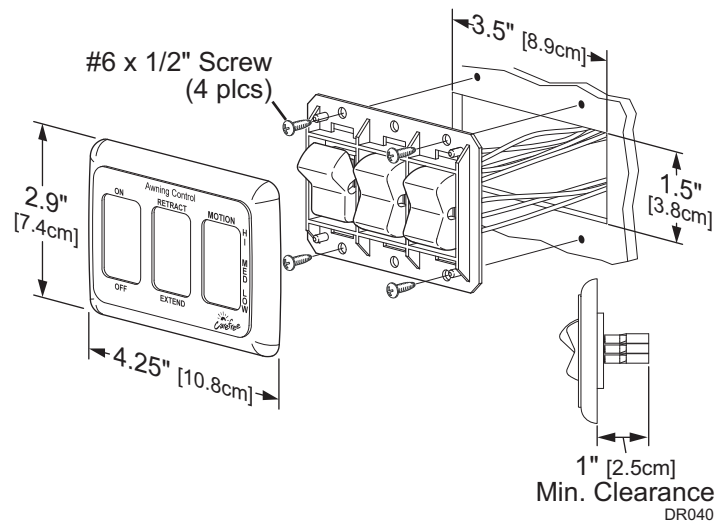

DR040

*Wiring an Additional Patio Switch*

This section is for wiring an additional PATIO switch.

(refer to the wiring diagram on page 10)

1. Route the switch wires to the main switch location.
2. Splice the wires in parallel with the EXTEND/RETRACT switch wires. Pin 1 of the additional switch should go to pin 1 of the main patio switch etc.

### Installing the Control Box

(refer to the wiring diagram on page 10)

1. Position the control box and secure using two (2) #6 x 1/2" screws.
2. Attach the switch harness connectors to the box at the positions labeled on the box. Press the connectors in until the tabs click into place to ensure a solid connection.
3. Connect the cable from the Direct Response sensor to the control box.
4. Connect a two-wire harness to the control box in the position marked MOTOR.
5. Run the motor wire cable from the awning to the control box. Splice the wires to the harness in step 4. The red wire should go to Pin marked "B" and the black goes to the pin marked "A".

**NOTE:** During testing, it may be necessary to reverse these wires (red to B, black to A) if the awning extend and retract functions are reversed.

6. Connect power to the control box;
  - 6.1. Run a 14 awg wire from the power distribution panel (auxiliary battery circuit) or equivalent.
  - 6.2. Run a 14 awg wire to chassis ground. Suitable ground would be the vehicle chassis or conductive structure connected to the chassis.
 

**NOTE:** If the wire run for ground or power is 30 feet or longer, use 12awg wire to prevent voltage drop.
  - 6.3. Connect a two-wire harness to the control box in the position marked +12V/GROUND.
  - 6.4. Splice the power and ground wires to the harness. Carefully note the labeling on the box so that the 12V power goes to the 12V pin and the ground goes to the pin labeled ground.

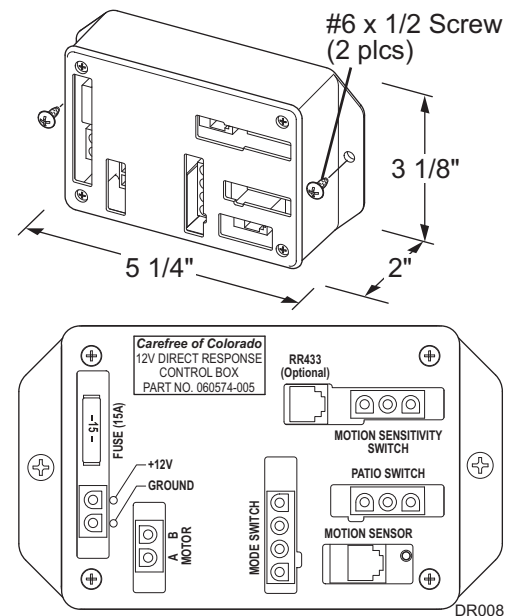

### Ignition Lockout Sensor Installation (Optional)

The optional STD ignition lockout disables the extend function when the module receives current through a switched 12VDC circuit.

A switched 12VDC source is a line that is "hot" when the ignition switch is in the on position; or, a 12VDC circuit through a relay that is "hot" when a specific condition is met (i.e. releasing the parking brake). Relays are furnished by the installer.

(Refer to the wiring diagram on page 10)

1. Disconnect power to the awning. Disconnect the battery or pull the appropriate circuit breaker.
2. Locate the control box for the Direct Response System.
 

**NOTE:** The 6" cable and splitter are for systems with a remote. If there is no remote, attach the 60" cable to the module; plug the other end directly to the "RR24" port in the control box. Then proceed with step 8.
3. If there is a remote receiver, disconnect the cable from the "RR24" port in the control box. Do not disconnect the cable from the receiver box.
4. Connect the supplied 6" cable to "RR24" port in the control box.
5. Attach the splitter to the other end of the cable.
6. Plug the cable from the remote receiver into the splitter.
7. Attach the Lock-Out Sensor to the end of the 60" cable. Route the cable as desired and connect the cable to the splitter.
 

**NOTE:** Wires to the module are not pin specific.
8. Attach one 18-gauge wire to a terminal of the sensor and route the wire to a suitable 12VDC ground.
9. Attach a second 18-gauge wire to the second terminal of the sensor and route the wire to a SWITCHED 12VDC source.
10. Bundle and secure the sensor, cable and wires as required.



### Installing the Remote Receiver

1. Determine the location of the optional RF receiver:
  - 1.1 Do not mount the unit near heat producing elements such as LP appliances or engine exhaust components.
  - 1.2 For best reception, do not mount the unit near or on a metal surface.
  - 1.3 Mount the unit with the antenna pointing up.
  - 1.4 The included cable is approximately 60 inches long. Mount the unit close enough to the control box so that the cord can be connected without stressing the connections.
  - 1.5 Allow room below the box to access the connector jack, programming button and indicator light.
2. Position the control box and secure using two (2) #6 x 1/2" screws.
 

**NOTE:** If the box is mounted on a surface that is less than 1/2" thick, the screws will protrude through the opposite side of the surface.
3. Connect the cable to the receiver.
4. If using the Ignition Lockout Sensor, route the cable to the splitter and connect. If not using the sensor connect the cable directly to the control box

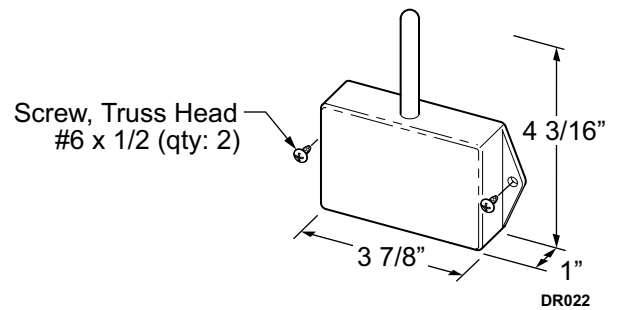

Figure 3. Mounting the RF Receiver.

### Programming the Receiver

These instructions apply to the current 433 MHz configuration of the remote and receiver. For older versions (418 MHz) refer to the Eclipse Service Manual.

1. Power to the control box must be on.
2. Press and release the "Press to Learn Transmitter" button on the bottom of the receiver box. The receiver is in program mode when the red light comes on.
3. Press and release the stop button on the remote. The red light will go out after the receiver learns the remote signal.

**NOTE:** Pressing the stop button will cause the blue up arrow button to default as the close (retract) function.

If a function button is pressed to train the receiver, it will be programmed as the close (retract) button. Example: Pressing the bottom button will program the bottom button for retract and the top button as extend.

4. Repeat for each additional remote.

#### OPERATIONAL NOTES:

- Transmitter and receiver operate on a frequency of 433 MHz.
- The receiver exits the program mode after ten seconds.
- If the light does not come on above, the memory is full and must be cleared. If the light still does not come on, check the continuity of the cord between the boxes and repair or replace as required. Pin 1 of the 1<sup>st</sup> connector goes to pin 1 of the 2<sup>nd</sup> connector etc.
- If the light does not go out in above, the receiver already knows the transmitter's signal or the battery in the remote needs to be replaced.
- To clear the memory: PRESS AND HOLD the transmitter learn button. While holding the button, the indicator light should be OFF for the full 5 seconds then come on.
- The system may be programmed for up to 5 remotes. Additional remotes may be ordered separately.

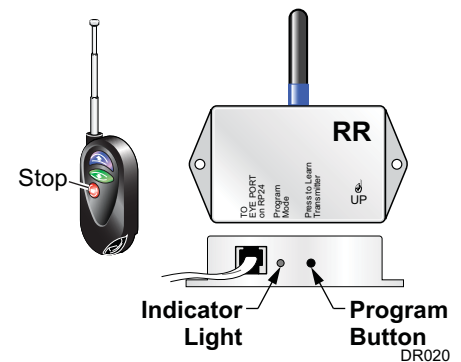

Wiring Diagram - Direct Response

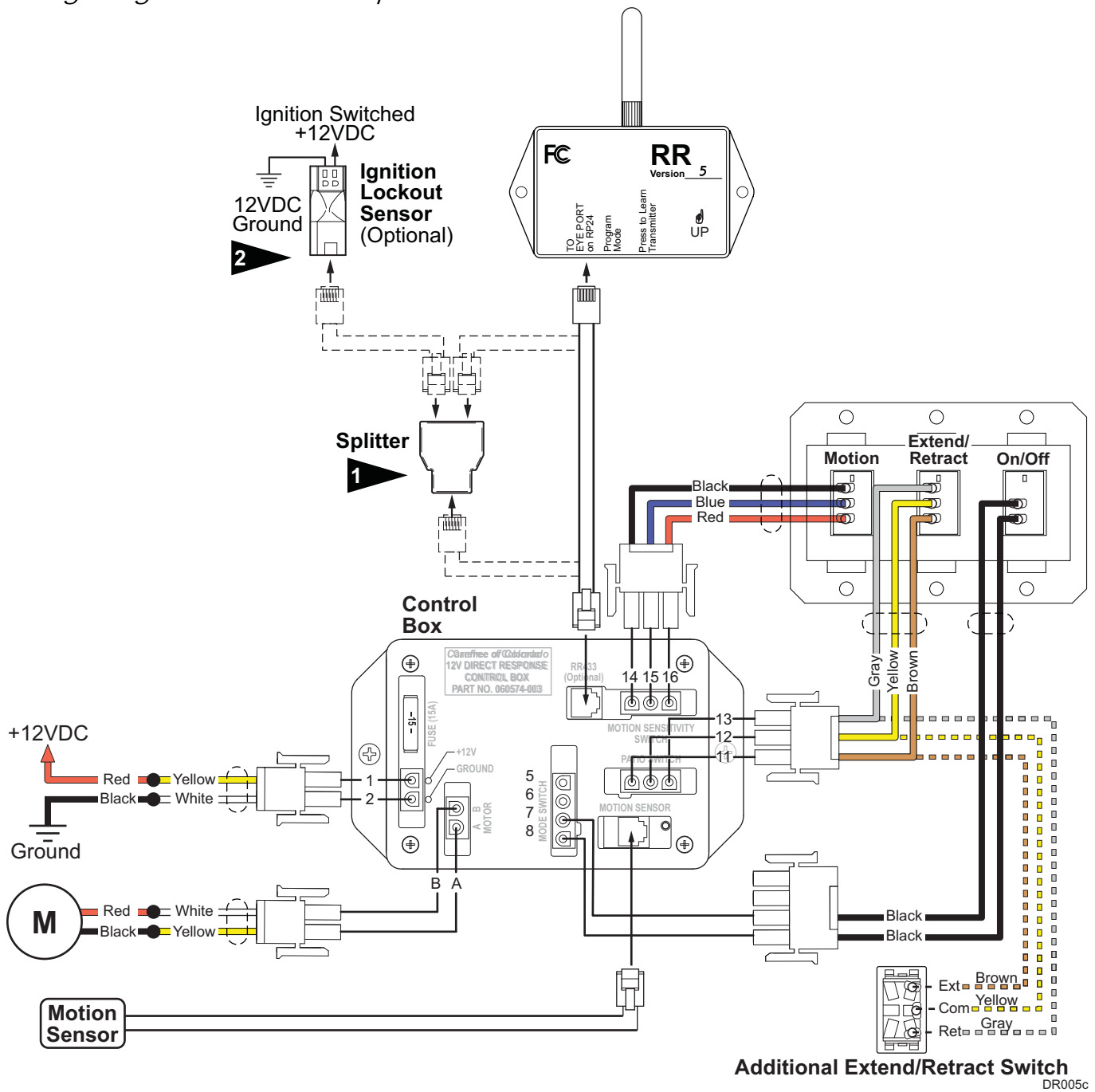

1

Splitter is used only when the optional Lock-Out Sensor is installed. Connect the RF receiver directly to the control box if Lock-Out is not installed.

2

The optional Lock-Out Sensor can be used only with control boxes marked "060574-003" or higher.

Wires for the sensor are not pin specific.

## SECURING THE FABRIC

1. Roll the awning in and out several times to make sure that the fabric is square on the rollbar.
2. Secure the canopy using one, #6 x 3/8" hex head screw at both sides of the awning.

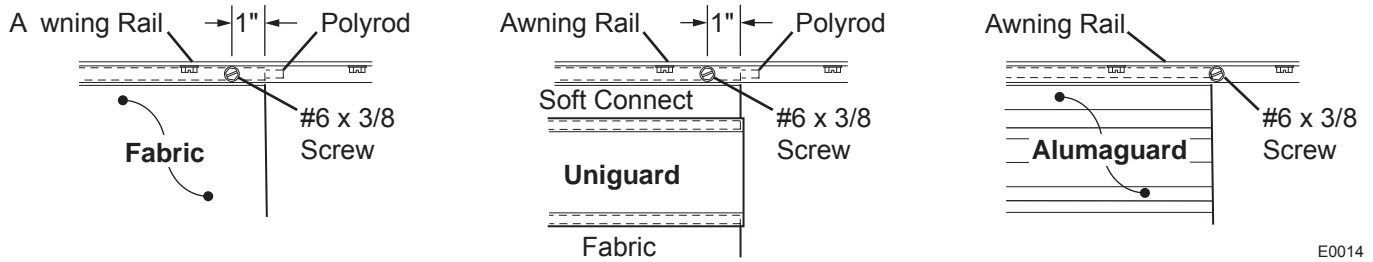

E0014

- 2.1 For vinyl awnings, place screw through awning rail, polyrod and canopy approximately 1" in from the end of the fabric.
- 2.2 For Uniguard awnings, place screw through awning rail, polyrod and the soft connect material approximately 1" in from the end of the fabric.
- 2.3 For Alumaguard awnings, place screw on the outer edge of the Alumaguard (not through the Alumaguard).

## REMOVING THE TEMPORARY ASSEMBLY PINS

2 pins are inserted into the back of the left (idler) head for lateral stability during installation. Using a pair of pliers, remove and discard both pins.

**NOTE:** The awning will temporarily operate with the pins in place; however, for long term use the pins must be removed.

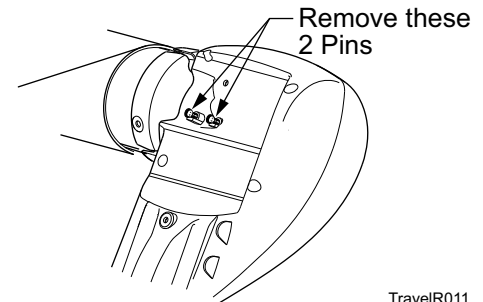

TravelR011

## INSTALLING THE TRACTIONERS

The tractioners are used with the Alumaguard and Uniguard metal fabric wraps.

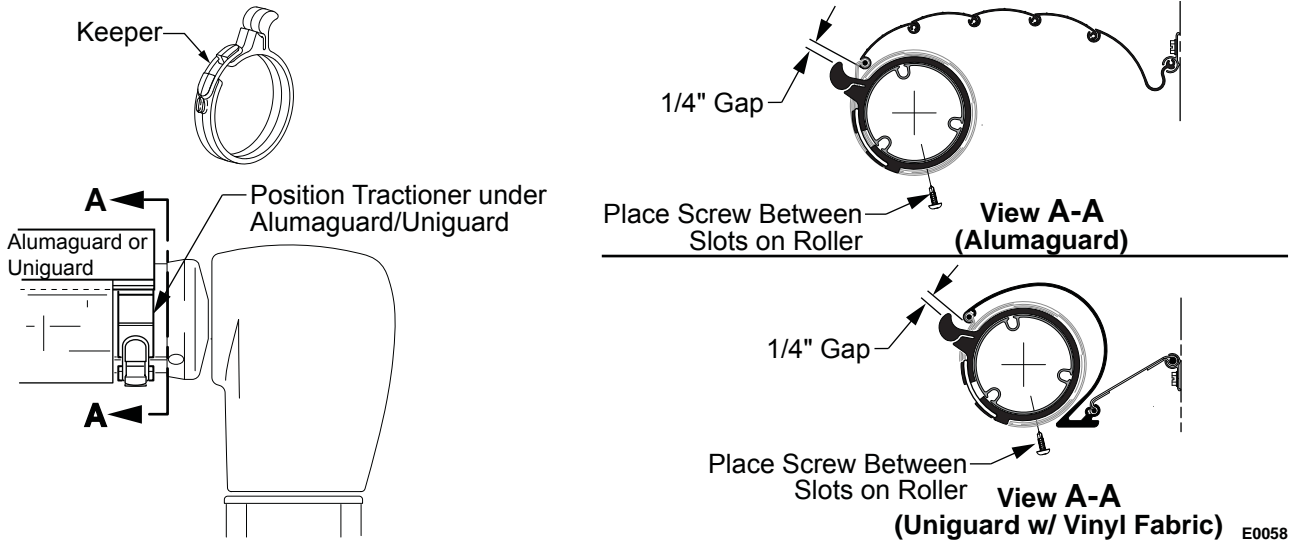

E0058

1. Partially extend the awning until the Alumaguard/Uniguard is extended as shown.
2. Unlock the keeper and wrap the tractioner around the roller tube.
3. Position the tractioner under the Alumaguard/Uniguard with a 1/4" gap between Alumaguard and tractioner. Lock the keeper.
4. Repeat for the other end of the rollbar.
5. Extend the awning to verify that the tractioners are lifting the metal wrap up and over the roller assembly.
6. To secure the tractioner, drill a 1/8" hole through the tractioner and roller tube, roughly center the hole between two slots of the rollbar.
7. Secure with one (1) #10 square drive screw.

## ATTACHING THE FASCIA

The fascia fits inside the rear channel.

1. Open the awning to provide access to the bottom of the rear channel.
2. Press the bottom dimples on the fascia into the rear channel until they snap into the bottom holes in the sides of the rear channel.
3. Press the top of the fascia into the rear channel until the upper dimples snap into the upper holes.

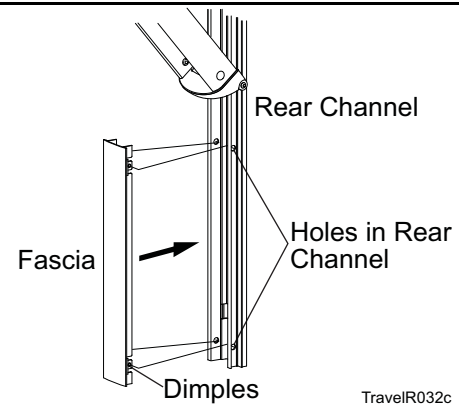

**Figure 4. Attaching the Fascia.**



# TRAVEL'R ARM EXTENSION

These instructions replace the following sections in the standard Travel'r Installation Manual:

**Page 5 "Assembling the Awning"**  
**Pages 6-7 "Mounting the Awning"**

These instructions are for mounting the Travel'r Patio Awning on RV's with corrugated siding and minimal structure. The extension allows the arm to be securely mounted to the floor line structure.

## ASSEMBLING THE AWNING

### 1. Size the rail extension for the installation:

1a. Measure the distance from the centerline of the awning rail to the center of the floor structure. This will be value "K".

1b. To determine the cut length ("L") of the extension:  
 L (flat pitch) =  $K - 64 \frac{5}{8}$ "  
 L (steep Pitch) =  $K - 57$ "

K = \_\_\_\_\_

Amount to Subtract - \_\_\_\_\_

L (Cut Length) = \_\_\_\_\_

1c. Cut the extension to the length "L". Cut off the end without the hole in the side.

1e. On the back of the extension, measure 4" down from the top and mark. Slide the top of the extension into the rear channel up to the mark and firmly hold or clamp in position.

1f. (Detail B) From the back of the arm, drill two 7/32" holes through the rear channel and into the extension. Attach the extension using two 3/16" pop rivets.

1g. Repeat for the other arm.

### 2. If the motor cable is to be routed through the RV wall at the top of the arm:

2a. Remove the plastic wrap at the top of the motorized arm. Partially open the arm being careful to not let the arm extend more than 6".

## **CAUTION**

**THE ARM IS UNDER TENSION FROM THE GAS SHOCK LOCATED IN THE ARM.**

2b. Pull the motor cable from the back of channel and out the hole in the top of the channel.

2c. Close the arm and secure closed position using a plastic wrap or equivalent.

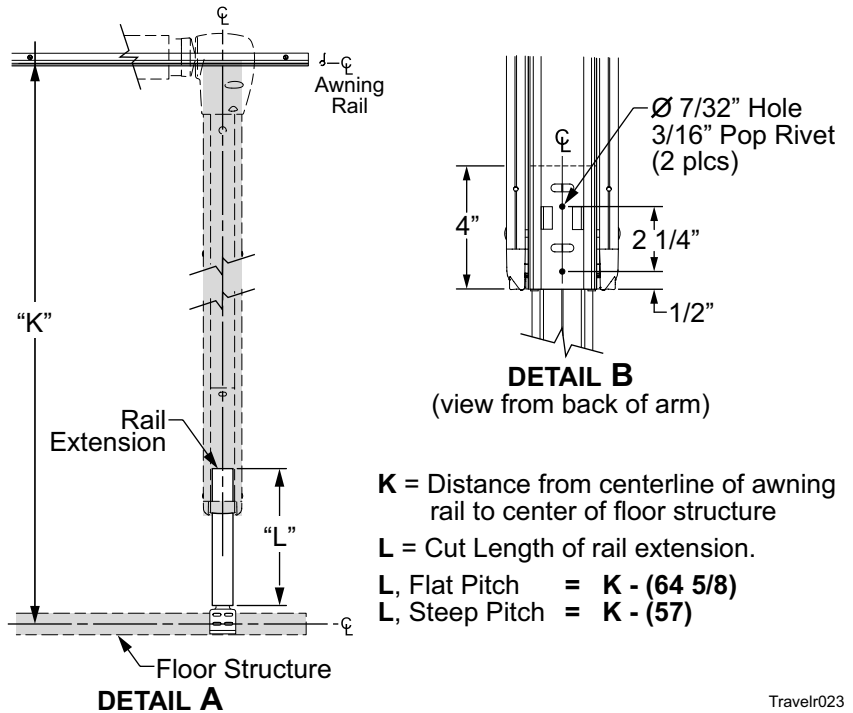

**K** = Distance from centerline of awning rail to center of floor structure  
**L** = Cut Length of rail extension.  
**L, Flat Pitch** =  $K - (64 \frac{5}{8})$   
**L, Steep Pitch** =  $K - (57)$

Travelr023

**Figure 1. Assembling the Awning.**

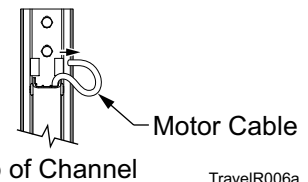

TravelR006a

**Figure 2. Top Cable Routing.**

3. If the motor cable is to be routed through the RV wall below the floor line:
  - 3a. On the back of the arm, carefully pull the cable out of the channel up to the squared access holes.
  - 3b. Drill a 1/2" hole through the squared hole and into the extension.
  - 3c. Route the cable into the hole and down inside the extension.

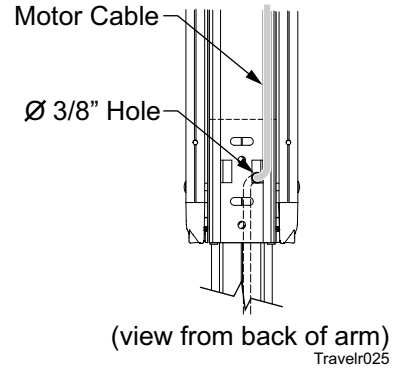
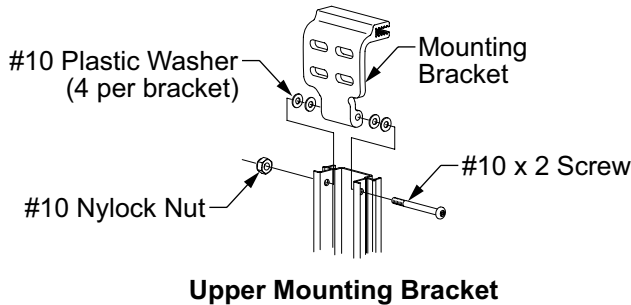
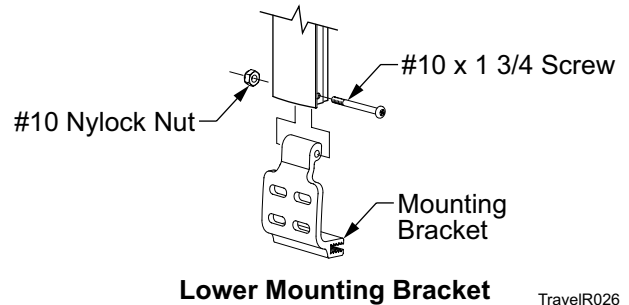

Figure 3. Routing the Cable.



Upper Mounting Bracket



Lower Mounting Bracket

Figure 4. Mounting Brackets.

4. (refer to Figure 4) On each arm attach the top mounting bracket to the channel using the screw, nut and washers as shown.
5. Attach the lower mounting bracket to the extension as shown.
6. Align the roller assembly with the end cap on the motorized arm assembly. Rotate the end cap until the slot in the cap aligns with the empty slot in the roller assembly, and then press the roller assembly fully into the cap. The end cap must seat squarely over the end of the roller assembly when complete.

**NOTE: The roller assembly must be oriented with the fabric going over the roller toward the mounting surface.**

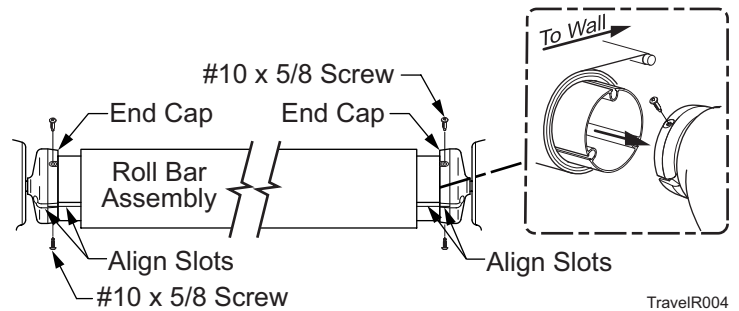

Figure 5. Assembling the Awning.

7. Secure the end cap to the roller assembly using two #10 square-drive screws.
8. Repeat steps 4 through 6 to attach the non-motorized arm assembly to the roller assembly.

**⚠ CAUTION**

**DURING ASSEMBLY AND INSTALLATION, THE ARM ASSEMBLIES MUST REMAIN PERPENDICULAR TO THE ROLLER ASSEMBLY. FAILURE TO HANDLE THE ARM ASSEMBLIES CAREFULLY CAN BEND THE DRIVE SHAFT.**

MOUNTING THE AWNING

**⚠ CAUTION**

**IT IS RECOMMENDED THAT AT LEAST THREE PEOPLE INSTALL THE AWNING DUE TO ITS SIZE AND WEIGHT.**

1. Check the location the awning is to be mounted. Ensure that the awning will not interfere with other equipment on the vehicle, such as a slide out room, light fixtures, exhaust vents etc.
2. Using a non-permanent method of marking, mark the centerline of the RH (motorized) arm. Ensure that it is perpendicular to the awning rail.
3. Unroll the canopy two wraps.

**NOTE: While the awning fabric is fairly robust, care must be taken not to snag it on the awning rail.**

4. With one person holding each arm, the third person should thread the polyrod (the plastic rod on the edge of the fabric) into the awning rail, starting at one end. Carefully move across the vehicle, gently pulling the fabric into the rail, until the awning is in the pre-determined location.
5. Position the motorized arm on the coach:
  - Align the center of the motorized arm with the centerline marked previously. Butt the top of the rear channel against the awning rail as shown in Figure 6.
  - The arm assembly must be perpendicular to the awning rail.

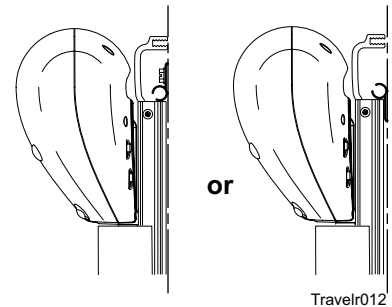

**Figure 6. Aftermarket Arm Positioning.**

6. Using the lower mounting bracket as a template, drill 5/32" pilot holes into the RV wall and attach the motorized arm using 1/4 x 2 1/2" lag screws. After attaching the lower bracket, it will be necessary to hold the arm in position while attaching the LH (idler) arm.
7. Position the roller assembly so that it is perpendicular to the motorized arm assembly. Position the non-motorized arm perpendicular to the roller assembly.
8. Using the lower mounting bracket as a template, drill 5/32" pilot holes into the RV wall and attach the LH (idler) arm using 1/4 x 2 1/2" lag screws. Hold the arm in position after attaching the lower bracket.
9. Hold the awning closed and carefully remove the plastic wraps at the top of the arms. The awning will partially open.
10. Hold the rear mounting channel against the wall. Ensure that the channel is perpendicular to the awning rail.
11. Drill 5/32" pilot holes and attach the upper mounting brackets to the wall using 1/4 x 2 1/4 lag screws.

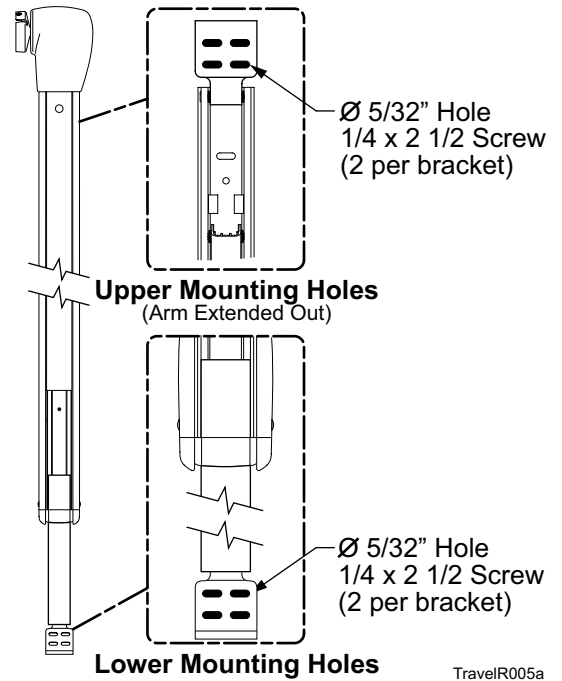

**Figure 7. Arm Mounting Holes.**



CAREFREE

# TRAVEL'R *DIRECT RESPONSE*

---

**AUTO-RETRACT SYSTEM**

The Travel'r Direct Response Auto-Retract System may be installed as part of the original Travel'r awning installation or as an upgrade to an existing awning installation.





## PROPRIETARY STATEMENT

The Travel'r Direct Response is a product of Carefree of Colorado, located in Broomfield, Colorado, USA. The information contained in or disclosed in this document is considered proprietary to Carefree of Colorado. Every effort has been made to ensure that the information presented in the document is accurate and complete. However, Carefree of Colorado assumes no liability for errors or for any damages that result from the use of this document.

The information contained in this manual pertains to the current configuration of the models listed on the title page. Earlier model configurations may differ from the information given. Carefree of Colorado reserves the right to cancel, change, alter or add any parts and assemblies, described in this manual, without prior notice.

Carefree of Colorado agrees to allow the reproduction of this document for use with Carefree of Colorado products only. Any other reproduction or translation of this document in whole or part is strictly prohibited without prior written approval from Carefree of Colorado.

## SAFETY INFORMATION

---

### WARNING

**A WARNING INDICATES A POTENTIALLY HAZARDOUS SITUATION WHICH, IF NOT AVOIDED, COULD RESULT IN DEATH OR SERIOUS INJURY AND/OR MAJOR PROPERTY DAMAGE.**

---

### CAUTION

**A CAUTION INDICATES A POTENTIALLY HAZARDOUS SITUATION THAT MAY CAUSE MINOR TO MODERATE PERSONAL INJURY AND/OR PROPERTY DAMAGE. IT MAY ALSO BE USED TO ALERT AGAINST UNSAFE PRACTICES.**

**NOTE: A note indicates further information about a product, part, or step.**

*Tip: A tip provides helpful suggestions.*

### Safety Notes:

- Always disconnect battery or power source before working on or around the electrical system.
- Always wear appropriate safety equipment (i.e. goggles).
- Always use appropriate lifting devices and/or helpers when lifting or holding heavy objects.
- When using fasteners, use care to not over tighten. Soft materials such as fiberglass and aluminum can be "stripped out" and lose the ability to grip and hold.

# INSTALLATION

## COMPONENT CHECKLIST

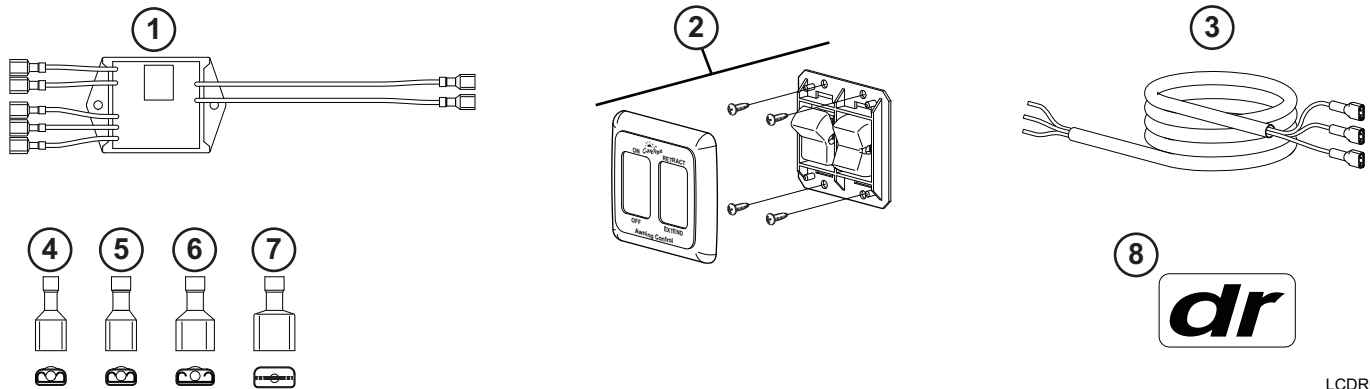

LCDR002

<input checked="" type="checkbox"/>	ITEM	DESCRIPTION		QTY	NOTE
<input type="checkbox"/>	1	Sensor Module		1	
<input type="checkbox"/>	2	Switch Kit		1	
<input type="checkbox"/>	3	Cable	205"	1	
<input type="checkbox"/>	4	Terminal, Female, .187	18-22 awg	3	
<input type="checkbox"/>	5	Terminal, Female, .187	14-16 awg	2	
<input type="checkbox"/>	6	Terminal, Female, .25	14-16 awg	1	
<input type="checkbox"/>	7	Terminal, Male, .25	14-16 awg	1	
<input type="checkbox"/>	8	Label, Direct Response		1	

### PRIOR TO INSTALLING THE KIT

*For New Installations* – These instructions assume that the awning and arms have been mounted and that the motor cable from the arm has been routed through the exterior wall as described in the awning installation instructions. These instructions replace the switch and wiring directions included with the awning.

*For Existing Installations* – The installer must locate and remove any existing switches. Access to the motor cable and the 12VDC/Ground wires is required.

1. Determine the location of the switches:
  - 1.1 Do not mount the switches near heat producing elements such as LP appliances or engine exhaust components.
  - 1.2 The dimensions for the switch plate are shown in Figure 2 on page 6.

### CAUTION

**ALWAYS DISCONNECT THE VEHICLE BATTERY AND ELECTRICAL SOURCES BEFORE WORKING WITH THE ELECTRICAL WIRING AND COMPONENTS.**

When the *Direct Response* installation is complete return to the original awning instructions for any final assembly required.

### INSTALLING THE SENSOR

This section is for fitting the motion sensor into the arm of an existing installation. If the sensor has been previously installed, go to "Installing the Switches" on page 5.

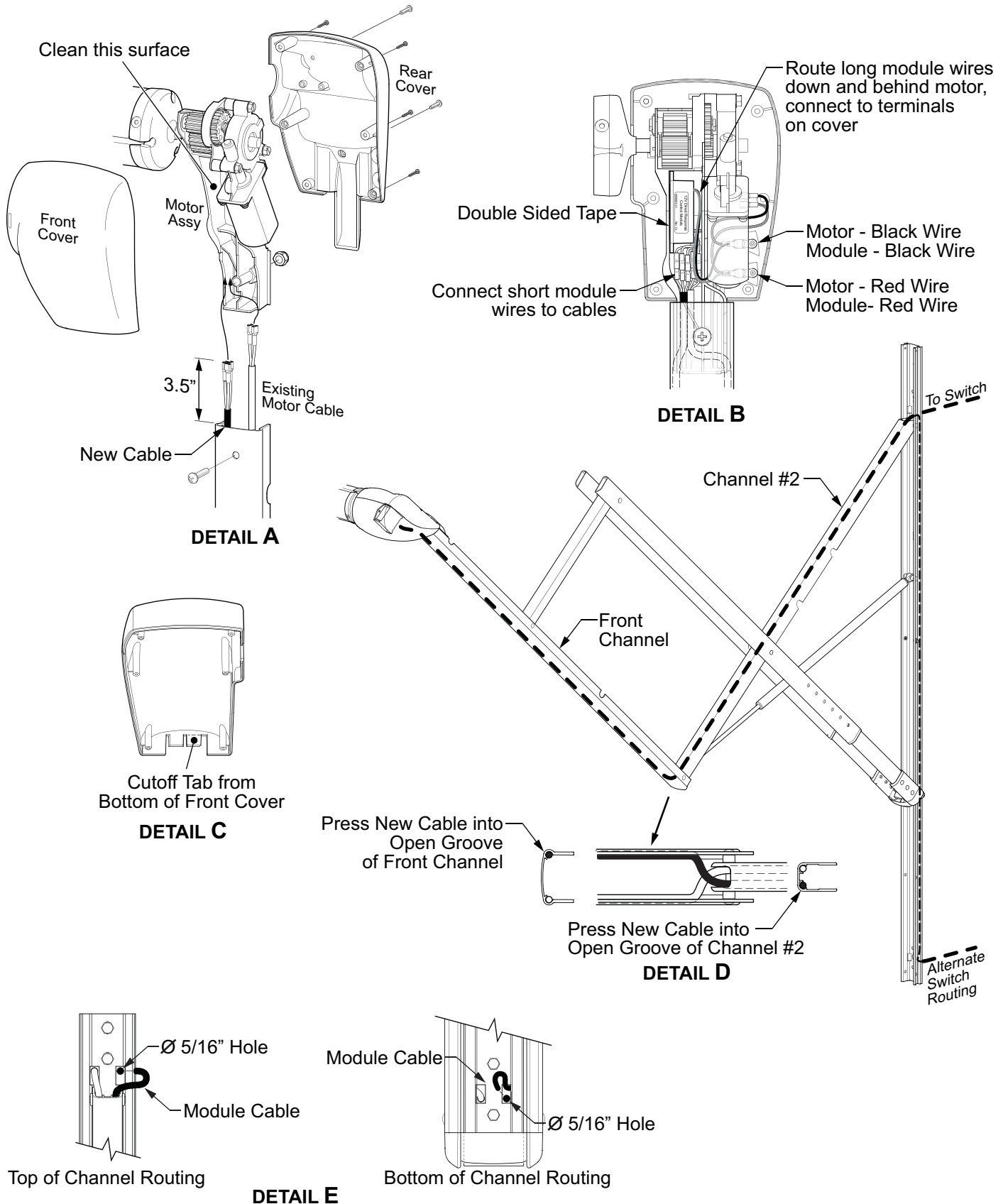

Figure 1. Mounting the Sensor.

1. Open the awning. The awning must be opened far enough to allow access to the back of the front channel and channel #2.
2. *(Detail A)* Remove the front cover. There are six (6) small screws through the back cover. Set cover and screws aside.
3. Remove the rear cover. Detach the wires at the double terminals on the cover. It is not necessary to detach the short wires from the motor.
4. Detach and support the roller tube.

 **CAUTION**

**DO NOT ALLOW THE ROLLER TUBE TO DROP TOWARD THE GROUND. THE TWISTING MOTION CAN CAUSE SERIOUS DAMAGE TO THE IDLER ARM.**

5. Detach and hold the motor assy from the arm.
6. *(Details A & B)* Route the existing motor cable to the left side of the motor frame and hold in place.
7. From inside the front channel, route the new module cable into the motor frame. The cable must extend above the front channel 3.5".
8. Reattach the motor assembly to the front channel.
9. Reattach the roller tube.
10. *(Detail B)* Clean the inner face of the motor frame. Then remove the release paper from the double-sided tape on the module. Position the module with the label out and the short wires pointing down then firmly press the module against the inside face of the motor frame. Ensure that the sensor does not touch the gears and that it is far enough inside to allow the front cover to be installed.
11. Connect the 5 short wires of the module to the wires from the cables. Match the colors of the wires. A wiring diagram is on page 6.
12. *(Detail B)* Route the long Red and Black wires from the module down and behind the motor.
13. On the rear cover, attach the wires to the double terminals.
14. Attach the wires from the motor to the double terminals on the cover. Make sure that the colors match. (Red to Red, Black to Black).
15. Attach the rear cover to motor assy.
16. *(Detail C)* Cut or break off the tab on the bottom of the front cover.
17. Attach the front cover.
18. *(Detail D)* Route the new cable down the front channel pressing the cable into the open groove.
19. At the pivot joint, slip the cable into channel #2 under the shock mount.  
**NOTE: The cable crosses from one side of the front channel to the opposite side of channel #2. This allows the cable to flex when the arm is opening or closing.**
20. Route the cable up channel #2 pressing the cable into the open groove.
21. Slip the cable through the open hole in the knuckle at the top of channel #2.
22. *(Detail E)* In the area shown, drill a 5/16" hole into the vehicle. Route the cable to the switch location.
23. For bottom routings:
  - 23.1. Remove the fascia.
  - 23.2. Loosen the attaching screws for the arm. If moly rivets have been used, it will be necessary to drill off the head of the rivet use care to not enlarge the hole.
  - 23.3. Slip the cable through the access hole at the top of the mounting channel and pull down. Lightly pull the cable out of the bottom access hole and align cable with the rear channel groove.
  - 23.4. Tighten the attaching screws for the arm. Replace any moly rivets that were removed.
  - 23.5. Reinstall the fascia.
24. Seal the hole and cable with a quality silicone sealant.

SWITCH INSTALLATION

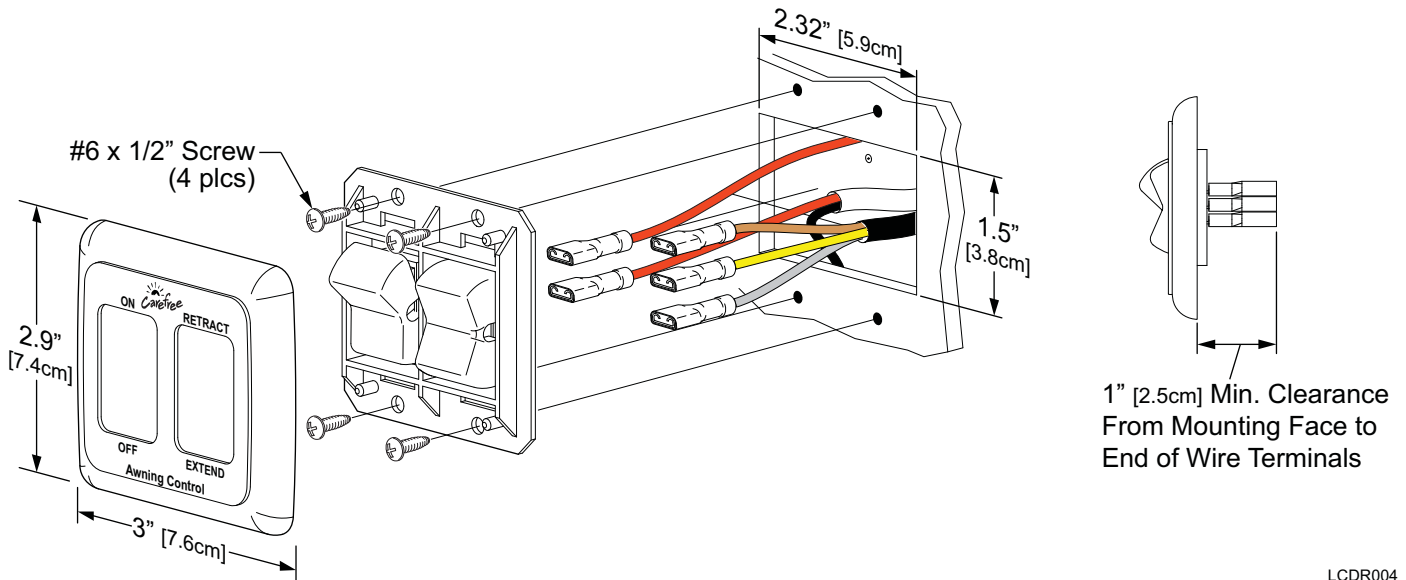

LCDR004

Figure 2. Mounting the Switches.

1. At the switch location cut a 2 5/16" [5.9cm] x 1 1/2" [3.8cm] hole.
2. Route the cables from the arm through the hole.
3. Terminate the 3 wires from the module cable with .187, 18-20 awg female terminals. Attach to the EXTEND/RETRACT switch as shown in the wiring diagram.
4. Terminate the RED wire from the motor cable with a .187, 14-16 awg female terminal. Attach to one terminal of the ON/OFF switch.
5. Terminate the BLACK wire from the motor cable with a .25, 14-16 awg male terminal.
6. Run a minimum 16 awg wire to chassis ground. Suitable ground would be the vehicle chassis or conductive structure connected to the chassis. Terminate the wire with .25, 14-16 awg female terminal.
7. Connect the ground wire to the black wire from the motor cable.
8. Run a minimum 16 awg wire from the power distribution panel (auxiliary battery circuit) or equivalent. Terminate the wire with a .187, 14-16 awg female terminal. Attach to one terminal of the ON/OFF switch.
9. Push the wires and switches into the hole then attach the switch frame using 4 #6 x 1/2" screws.
10. Snap the switch bezel over the switch frame.

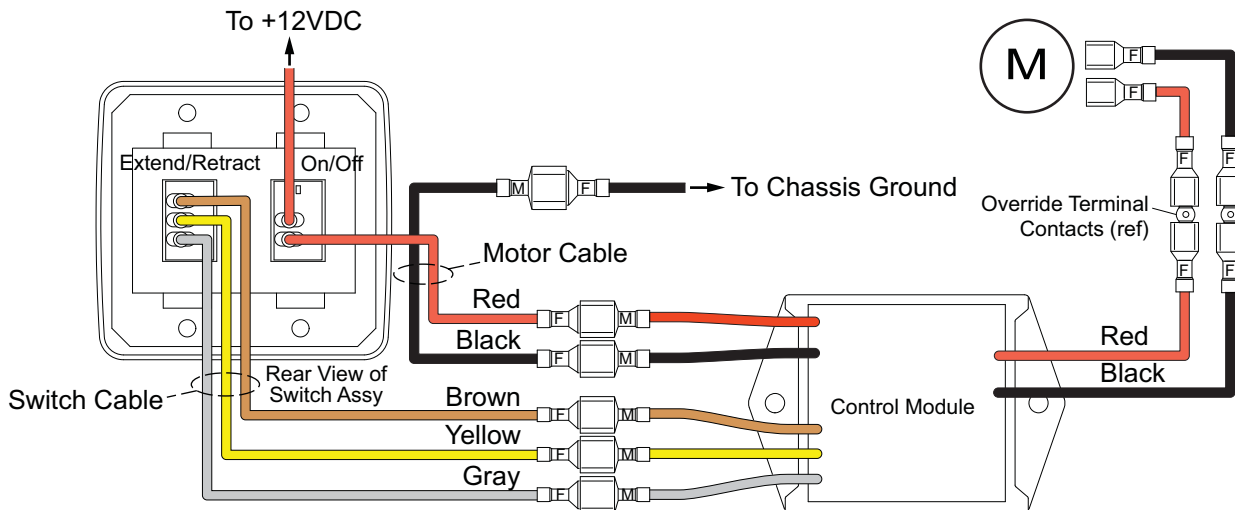

Figure 3. Wiring Diagram.

LCDR003

## ATTACH THE LABEL

After completing and testing the system, attach the Direct Response identification label to the bottom of the motor arm.

1. Thoroughly clean and dry the area at the bottom of the RH (motor) arm.
2. Remove the release paper and attach the "DR" label in the area shown between the Carefree logo and the top of the plate.

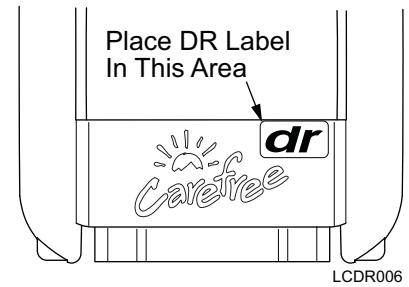

**Figure 4. Direct Response Label.**



# INSTALLATION MANUAL

## TRAVEL'R ARMS AND CANOPY

THIS MANUAL PROVIDES INSTRUCTIONS FOR  
ORIGINAL EQUIPMENT MANUFACTURER (OEM), AFTERMARKET INSTALLATIONS AND  
ARM UPGRADES FOR CURRENT CAREFREE AND A&E AWNINGS

RV



## PROPRIETARY STATEMENT

The Travel'r Patio Awning is a product of Carefree of Colorado, located in Broomfield, Colorado, USA. The information contained in or disclosed in this document is considered proprietary to Carefree of Colorado. Every effort has been made to ensure that the information presented in the document is accurate and complete. However, Carefree of Colorado assumes no liability for errors or for any damages that result from the use of this document.

The information contained in this manual pertains to the current configuration of the models listed on the title page. Earlier model configurations may differ from the information given. Carefree of Colorado reserves the right to cancel, change, alter or add any parts and assemblies, described in this manual, without prior notice.

Carefree of Colorado agrees to allow the reproduction of this document for use with Carefree of Colorado products only. Any other reproduction or translation of this document in whole or part is strictly prohibited without prior written approval from Carefree of Colorado.

## SAFETY INFORMATION

---

**⚠ WARNING** A WARNING INDICATES A POTENTIALLY HAZARDOUS SITUATION WHICH, IF NOT AVOIDED, COULD RESULT IN DEATH OR SERIOUS INJURY AND/OR MAJOR PROPERTY DAMAGE.

---

**⚠ CAUTION** A caution indicates a potentially hazardous situation that may cause minor to moderate personal injury and/or property damage. It may also be used to alert against unsafe practices.

**NOTE:** A note indicates further information about a product, part, or step.

*Tip:* A tip provides helpful suggestions.

### Safety Notes:

- To avoid shock hazard and/or accidental system shorting, always disconnect battery or power source before working on or around the electrical system.
- Always wear appropriate safety equipment (i.e. goggles).
- Awnings have significant weight. Always use appropriate lifting devices and/or helpers when lifting or holding heavy objects.
- When using fasteners, use care to not over tighten. Soft materials such as fiberglass and aluminum can be "stripped out" and lose the ability to grip and hold.



## PRODUCT OVERVIEW

The Travel'r provides motorized awning comfort with Carefree's standards for looks, strength and dependability. It is the successful blend of style, quality and economy. The awning is available in two fixed pitch models.

The awning roller tube and arms are made from light weight, no-rust aluminum. The awning fabric is heavy weight vinyl.

### Travel'r Patio Awning Specifications:

<b>MAXIMUM EXTENSION:</b>		8 foot	<b>MAXIMUM LENGTH:</b>		21 feet
<b>PITCH:</b>	<b>STEEP</b>	<b>DROP:</b>	approximately 33 inches		
Measurement is from centerline of Awning Rail to centerline of roller tube.					
<b>MOTOR:</b>		Power: 10VDC-14VDC	<b>Circuit Rating:</b> 15 amp		motor mounted in arm
<b>POWER SOURCE:</b>		Motor and controls are routed and hardwired into the vehicle's 12V system			
<b>EXTEND ACTUATION:</b>		Gas Shock			
<b>POSITION CONTROL:</b>		Motorized roll out/in			
<b>CONTROLLER:</b>		3 position, momentary ON, center OFF Switch			
<b>COLOR:</b>	<b>Frame:</b>	White, Black			
	<b>Canopy:</b>	Available in a Variety of fabrics and colors – refer to order sheet			

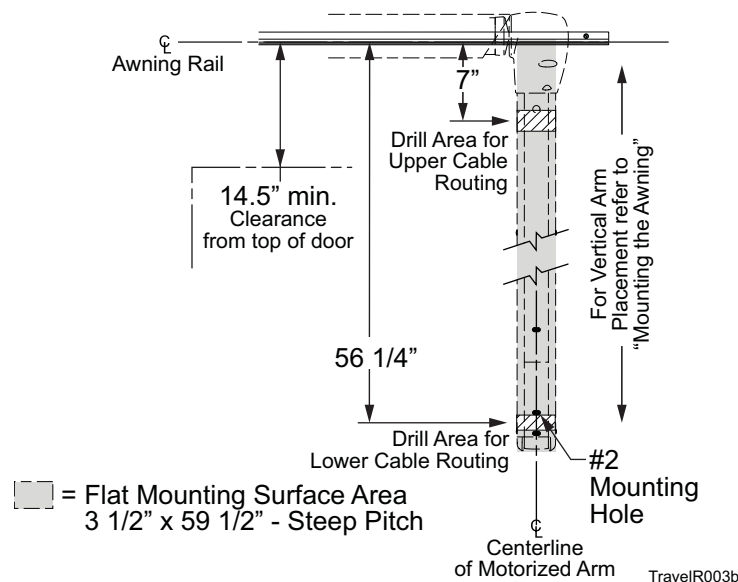

COMPONENT CHECKLIST

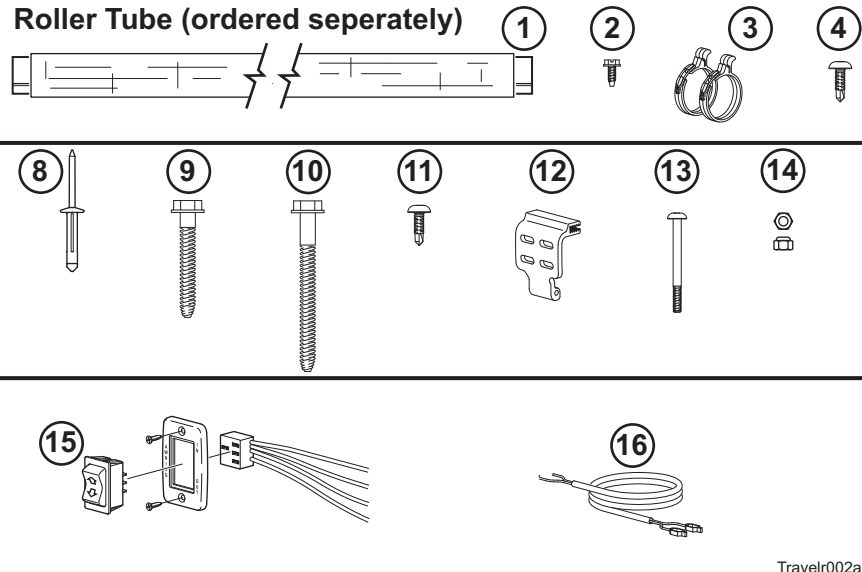
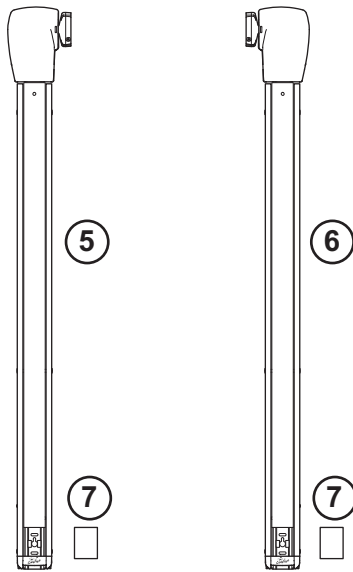

Travelr002a

<input checked="" type="checkbox"/>	ITEM	DESCRIPTION	QTY		NOTE
			A	B	
	<b>A = OEM; B = Aftermarket</b>				
<input type="checkbox"/>	1	Roller Tube Assembly	1	1	
<input type="checkbox"/>	2	Screw, Hex Washer Head	2	2	
<input type="checkbox"/>	3	Tractioner	2	2	2
<input type="checkbox"/>	4	Screw, Truss Head, SQ Drive	2	2	2
<input type="checkbox"/>	5	Arm Assembly, LH	1	1	1
<input type="checkbox"/>	6	Arm Assembly, RH	1	1	1
<input type="checkbox"/>	7	Fascia	2	2	
<input type="checkbox"/>	8	Rivet, Moly	--	10	
<input type="checkbox"/>	9	Screw, Lag	--	10	
<input type="checkbox"/>	10	Screw, Lag	--	4	
<input type="checkbox"/>	11	Screw, Truss Head, Sq Drive	4	4	
<input type="checkbox"/>	12	Top Mounting Bracket		2	
<input type="checkbox"/>	13	Screw, Phillips Pan Head		2	
<input type="checkbox"/>	14	Nylock Nut		2	
<input type="checkbox"/>	15	Switch Kit	Note	1	4
<input type="checkbox"/>	16	Jumper Cable	1	1	3

- Notes:
1. Awning configuration is specified at time of order, including awning length, fabric, color etc. Check awning assembly against original purchase order. Arms are configuration specific and are not interchangeable.
  2. Screws and Tractioners are furnished with roller tube assemblies equipped with optional Alumaguard.
  3. Place Jumper Cable (item 16) and Owner's Manual (item 17) with RV owner information.
  4. For OEMs, the Carefree switch kit is purchased separately and not included with the arms. OEM's may choose to furnish the control switch. The switch must be a DC polarity reversing switch with dynamic brake.

## INSTALLATION

### REQUIRED PRE-INSTALLATION PREPARATION

1. Park the vehicle on a flat surface and level the unit.
2. IF THIS IS AN UPGRADE FOR A MANUAL PATIO AWNING: follow the awning manufacturer's instructions and remove the awning from the coach including the roll bar and canopy.
  - a. Remove all brackets.
  - b. Plug and seal all mounting holes. The new Travel'r arms may not match the locations of the old awning arms.
  - c. Remove the roll bar from the arms and on a flat clean surface, roll the fabric onto the roll bar.
  - d. If the canopy is equipped with Alumaguard, remove the tractioners and set aside. These will be reinstalled after the new awning assembly is installed.
3. IF THIS IS AN UPGRADE FOR A ONE-TOUCH AWNING:
  - a. If the existing installation uses an external wall plug, the installer must furnish the mating plug for the new motor wires or remove the wall connector and wires. Plug and seal the hole then follow the standard wiring instructions.
  - b. Determine the existing wiring configuration:
    - *Configuration A* – Direct connection to switch. Motor wires connect directly to switch through the wall-mount connector. If the connector is retained (see step a), it is not necessary to remove the existing switch.
    - *Configuration B* – Control box electronics. A control box is installed between the connector and switches. Disconnect and remove the existing control boxes, wiring and switches. The system is replaced with the single switch control.
    - *Configuration C* – Auto Retract –All. Disconnect and remove the existing control boxes, wiring and switches. The system is replaced with the single switch control. Travel'r Direct Response Auto-Retract is available as a separate upgrade kit (SR0093) for the Travel'r Patio Awning.
  - c. Remove the awning from the coach including the roll bar and canopy.
  - d. Remove all brackets.
  - e. Plug and seal all mounting holes. The new arms may not match the locations of the old awning arms.
  - f. Remove the roll bar from the arms and on a flat clean surface, roll the fabric onto the roll bar.
  - g. If the canopy is equipped with Alumaguard, remove the tractioners and set aside. These will be reinstalled after the new awning assembly is installed.
4. For upgrades, follow the instructions for aftermarket installations.
5. Check where the awning arms will be installed. The arms fit snug to the side of the vehicle and must not cover or interfere with exhaust vents, lights etc.
6. If there is an awning rail installed, check that the awning rail runs the full length of the awning. Please refer to the note under "Installing an Awning Rail" before proceeding.
7. Refer to the important note on page 6 about the required positioning of the centerline of the roll bar.
8. For the bottom 3 mounting holes: if mounting into structure, use the 1/4 x 1 1/2 screws; if not attaching into structure, use the furnished moly rivets.

**NOTE:** The upper mounting holes (all configurations) MUST attach into structure using the screws provided.

*OEM Installations:* If structural backing is not available for the upper mounting holes, it will be necessary to use the aftermarket upper arm mounting bracket so that the upper brackets can mount into the structural members at the roof line.

## INSTALLING AN AWNING RAIL

**NOTE: For canopies WITHOUT Alumaguard or Uniguard:** If the vehicle already has a full-length awning rail installed, skip to step 5. The awning rail and arms must be positioned so that any existing trim does not interfere with the awning arm when in the closed position.

**For Alumaguard and Uniguard installations:** If the existing awning rail is incorporated into the coach trim or a drip rail, it will be necessary to mount a standard awning rail flat on the coach wall. The awning rail and arms must be positioned so that any existing trim does not interfere with the Alumaguard or Uniguard's "Flex Connect" or the awning arm when in the closed position.

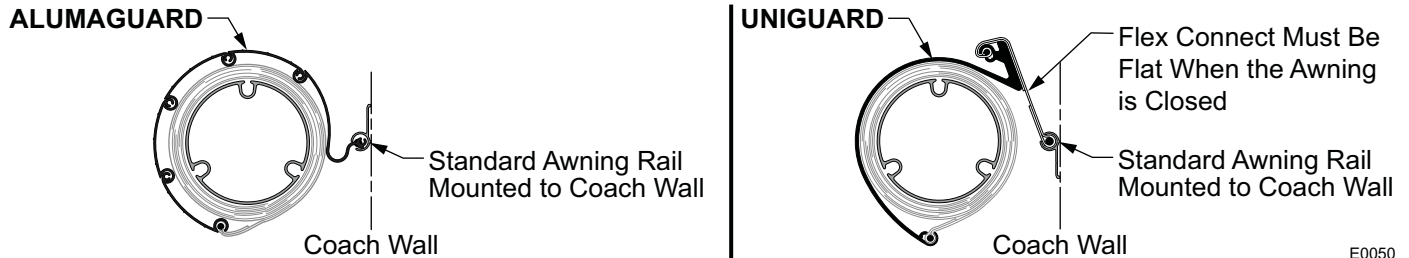

1. Determine the optimum positioning of the awning so that the arms will not interfere with the door frame or light fixtures. The centerline of the awning rail should be above the door opening a minimum of 6" for vinyl and 7" for Alumaguard/Uniguard. After determining mounting position, mark the position with a chalk line.
2. Awning rail must be level.
3. Seal the back of the rail with silicone sealant or putty tape.
4. Align the awning rail onto the wall and secure with #10 x 3/4" screws. Use all the attach holes in the rail.

**⚠ CAUTION** Make sure the screws are securely mounted to the structural frame of the vehicle.

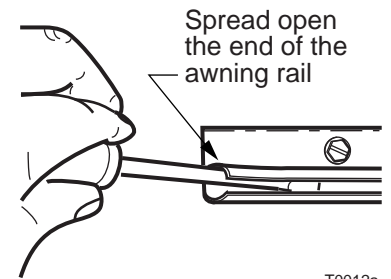

5. Use a screwdriver to spread open one end of the awning rail on the installation side.
6. File any sharp edges or burrs from the end of the rail. This will help protect the awning fabric from damage during installation.
7. Spray inside the awning rail track with a dry silicone lubricant.

**STOP** – If using the optional arm extension for mounting, follow the directions for "Assembling the Awning" and "Mounting the Awning" in Installation supplement 052540-102 - "Travel'r Arm Extension".

## ASSEMBLING THE AWNING

1. Decide on the location of the switch to determine the cable routing.
2. If the motor cable is to be routed through the RV wall at the bottom of the arm, slip the cable through the slot at the bottom of the track (refer to **Error! Reference source not found.**). Go to step 4.
3. If the motor cable is to be routed through the RV wall at the top of the arm:
  - 3.1 Remove the plastic wrap at the top of the motorized arm. Partially open the arm being careful to not let the arm extend more than 6".

**NOTE: The arm is under tension from the gas shock located in the arm.**

- 3.2 Pull the motor cable from the back of channel and out the hole in the top of the channel.
- 3.3 Close the arm.
- 3.4 Secure the top of the arm in the closed position using a plastic wrap or equivalent.

### 4. **For Aftermarket and Upgrade Installations:**

On each arm attach the top mounting bracket to the channel using the screw and nut and as shown.

5. Align the roller assembly with the end cap on the motorized arm assembly. Rotate the end cap until the slot in the cap aligns with the empty slot in the roller assembly, and then press the roller assembly fully into the cap. The end cap must seat squarely over the end of the roller assembly when complete.

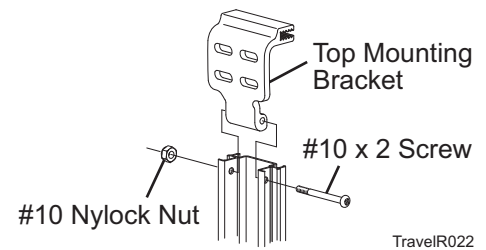

**NOTE: The roller assembly must be oriented with the fabric going over the roller toward the mounting surface.**

6. Secure the end cap to the roller assembly using two #10 square-drive screws.
7. Repeat steps 5 and 6 to attach the non-motorized arm assembly to the roller assembly.

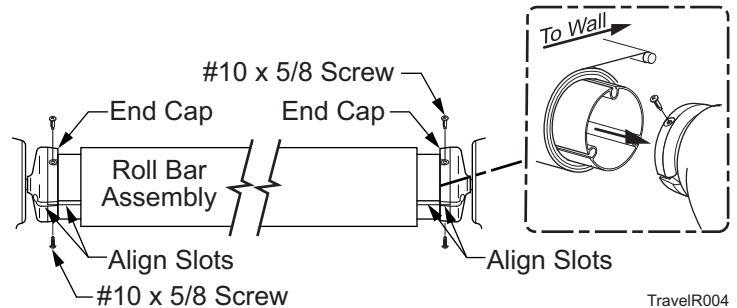

**⚠ CAUTION** During assembly and installation, The arm assemblies must remain perpendicular to the roller assembly. Failure to handle the arm assemblies carefully can bend the drive shaft.

## MOUNTING THE AWNING

**⚠ CAUTION** It is recommended that at least three people install the awning due to its size and weight.

(Refer to the General Layout on page **Error! Bookmark not defined.**)

1. Check the location the awning is to be mounted. Ensure that the awning will not interfere with other equipment on the vehicle, such as a slide out room, light fixtures, exhaust vents etc.
2. On the awning rail, mark the location of the centerline of the motorized arm assembly.
3. Unroll the canopy one wrap.

**NOTE:** While the awning fabric is fairly robust, care must be taken not to snag it on the awning rail.

4. With one person holding each arm, the third person should thread the polyrod (the plastic rod on the edge of the fabric) into the awning rail, starting at one end. Carefully move across the vehicle, gently pulling the fabric into the rail, until the awning is in the pre-determined location.
5. Position the motorized arm on the coach: Align the center of the motorized arm with the centerline marked in step 2. Butt the top of the rear channel against the awning rail as shown.

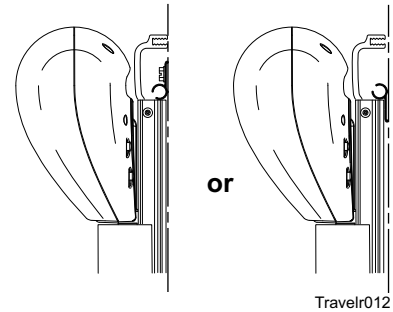

**IMPORTANT NOTE:** For Uniguard and Alumaguard installations, the centerline of the roll bar must be  $3/4'' \pm 1/4''$  above the centerline of the awning rail. If the arm cannot be positioned as shown and meet this requirement because of trim below the awning rail, the installer must remove the trim where the arms mount or install a new awning rail below the trim.

6. Hold the arm assembly perpendicular to the awning rail and drill a  $5/32''$  hole through the #2 mounting hole and attach the motorized arm using a  $1/4 \times 1 \ 1/2''$  lag screw

**NOTE:** For the bottom 3 mounting holes: when attaching into structure, use  $1/4 \times 1 \ 1/2$  screws; if not attaching into structure, use the furnished moly rivets. Moly rivets require a  $1/4''$  hole in place of the  $5/32''$  pilot hole.

The upper mounting holes (all configurations) must be attached into structure using the screws provided.

*OEM Installations:* If structural backing is not available for the upper mounting holes, it will be necessary to use the aftermarket top brackets to attach into the structural members at the roof line.

7. Confirm that the arm is perpendicular to the awning rail, attach the arm through the #1 mounting hole (shown in) using a 5/32" pilot hole and a 1/4 x 1-1/2" lag screw.
8. Position the roller assembly so that it is perpendicular to the motorized arm assembly. Position the non-motorized arm perpendicular to the roller assembly.
9. Drill a 5/32" hole through the #2 mounting hole and attach the non-motorized arm using a 1/4 x 1 1/2" lag screw.
10. Check the alignment; the arm assembly must be perpendicular to the roller assembly. When the alignment is correct, drill and attach the arm through the #1 mounting hole (shown in) using a 5/32" drill bit and a 1/4 x 1-1/2" lag screw.
11. Hold the awning closed and carefully remove the plastic wraps at the top of the arms. The awning will open a few inches.
12. Open the awning about 18" or until the top mounting holes on the arms are visible. To open
  - 12.1. Temporarily connect the ends of the motor wires to a 12V-14V source (i.e. drill battery). If the awning does not begin to move, reverse the leads.
  - 12.2. Remove the battery after the awning is open.

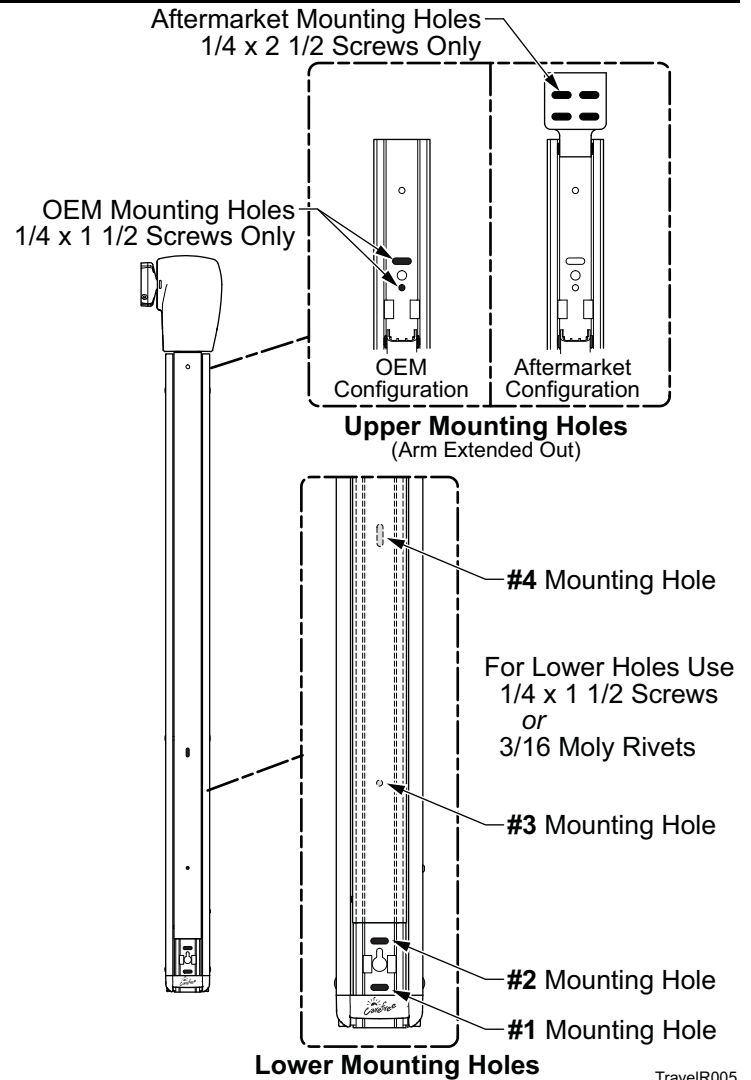

TravelR005

13. For Aftermarket configurations: Drill 5/32" pilot holes for the upper mounting holes through the bracket and the #3 lower mounting hole for each arm. Then attach the upper mounting bracket using 2 ea 1/4 x 2 1/2 lag screws. Attach either the #3 or #4 lower mounting hole with a 1/4 x 1 1/2 lag screw or moly rivet.
14. For OEM configurations: Drill 5/32" pilot holes for the upper mounting holes then attach using 2 ea 1/4 x 1 1/2 lag screws. Attach either the #3 or #4 lower mounting hole with a 1/4 x 1 1/2 lag screw or moly rivet.

## SWITCH AND WIRING INSTALLATION

**⚠ CAUTION** Always disconnect the vehicle battery and electrical sources before working with the electrical wiring and components.

- Notes:**
1. Failure to follow the wiring instructions in this publication may void the motor warranty.
  2. DO NOT wire two or more motors to one switch—No parallel wiring.
  3. All wiring must conform to NEC (National Electrical Code) and local codes.
  4. OEM's may choose to furnish the control switch. The switch must be a DC polarity reversing switch with dynamic brake.

1. Determine the final location of the switch.

**NOTE:** If the distance from point of entry to the switch location is greater than 32" [81cm], the installer must furnish a splice between the motor cable and switch location.

2. FOR ONE-TOUCH UPGRADES:

- 2.1 If the external wall plug has been removed and sealed, go to step 3.
- 2.2 If using the wall plug, measure the motor cable from the arm to the plug. Trim the wire and terminate with an installer furnished mating connector. Attach the new connector to the wall plug and proceed to step 12.

3. For installations using the cable with a direct connection to the switch (no external plug).

- 3.1 Drill a 5/16" hole through the vehicle wall for the motor cable.
- 3.2 Route the cable through the hole to the switch location.
- 3.3 Seal the cable and hole using a silicone sealant.

4. At the switch location, cut a rectangular hole 1.25" [3.2cm] x 1.88" [4.8cm].

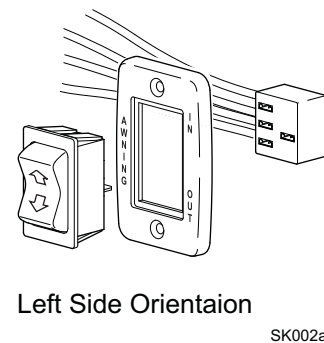
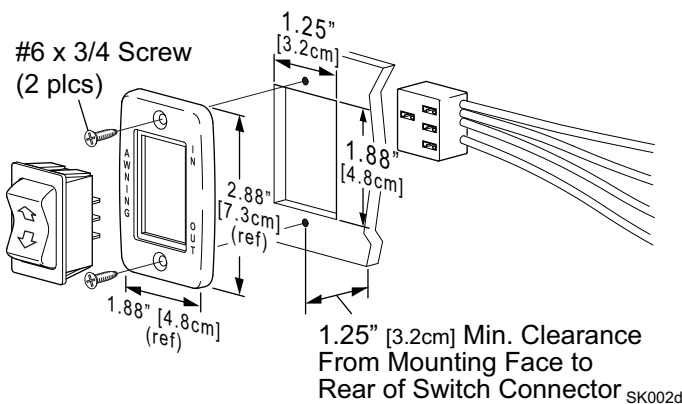
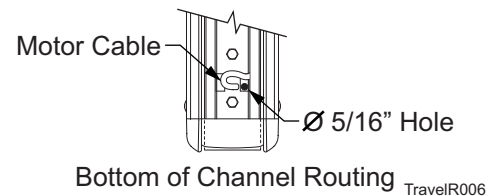
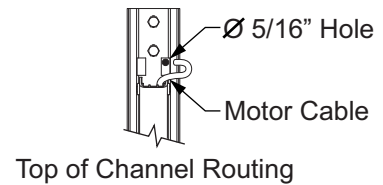

5. Determine the switch orientation:

- 5.1. The wires of the connector extend from the side of the switch with 3 terminals on the back.
- 5.2. For wire routing on the right side of the switch as shown in Details A and B, orient the switch with the 3 terminals on the right.
- 5.3. For wire routing on the left side of the switch as shown in Detail C, orient the switch with the 3 terminals on the left.
- 5.4. Push the switch into the faceplate until the tabs on the switch "click" into place behind the faceplate. Ensure that the switch and faceplate are oriented so that the lettering is up and the wires are oriented as desired.
- 5.5. Set switch aside.



6. Route the awning motor wires through the switch hole and attach to the switch connector:

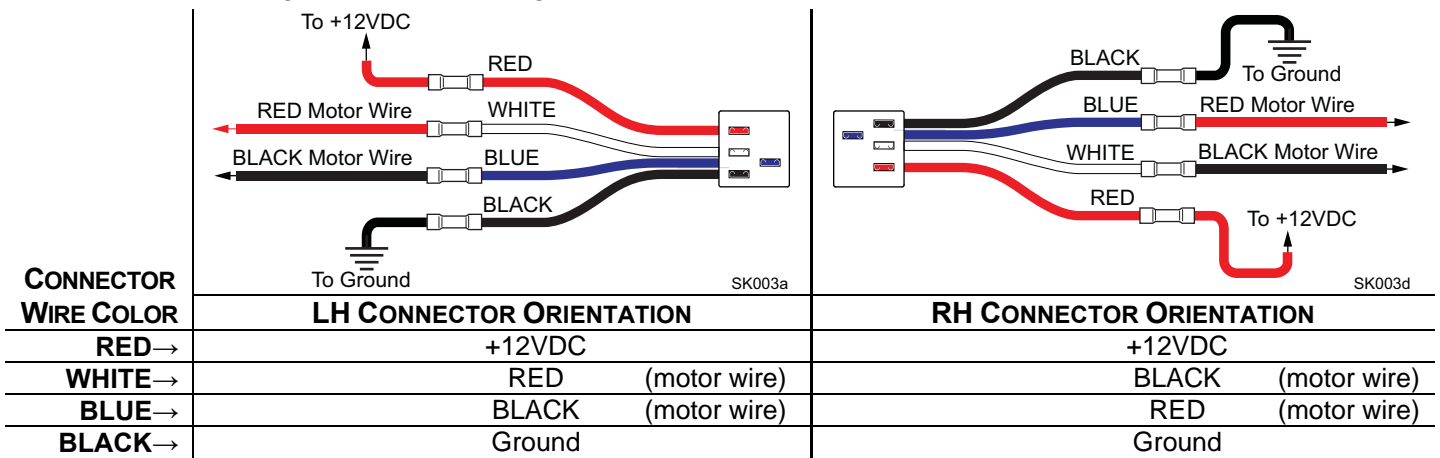

7. Run a minimum 14 awg wire from the power distribution panel (auxiliary battery circuit) or equivalent. The circuit should be protected by a 15-amp fuse.
8. Run a minimum 14 awg wire to system ground.
 

**NOTE:** If the wire run is 30 feet or longer, use 12awg wire to prevent voltage drop.
9. Route the two wires through the mounting hole. Butt splice the 12VDC wire to the RED connector wire. Butt splice the ground wire to the BLACK connector wire.
10. Attach the connector to the switch.
11. Restore power and test the switch operation.
12. If the awning operates opposite to the switch plate markings:
  - Shut off power;
  - Reverse motor wires connected to the blue and white connector wires;
  - Restore power and test.
13. Push the wires, connector and switch into the mounting hole and secure the switch plate. Use two (2) #6 x 3/4" flat head screws.

**SECURING THE FABRIC**

1. Roll the awning in and out several times to make sure that the fabric is square on the rollbar.
2. Secure the canopy using one, #6 x 3/8" hex head screw at both sides of the awning.

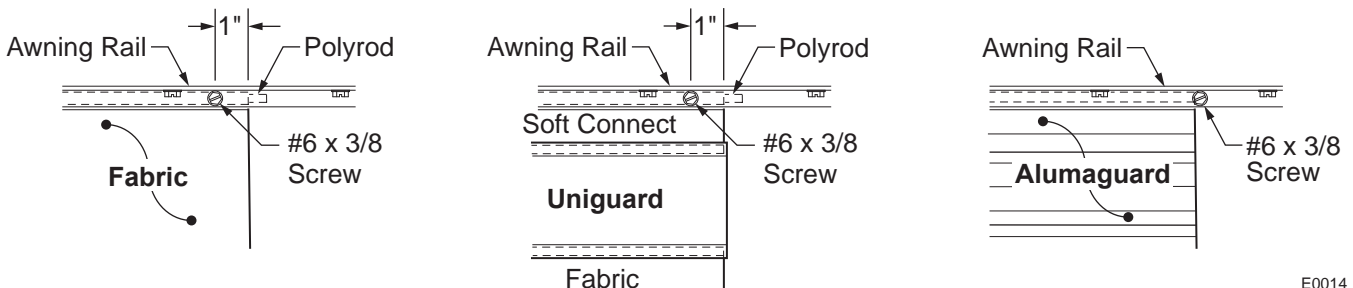

E0014

- 2.1 For vinyl awnings, place screw through awning rail, polyrod and canopy approximately 1" in from the end of the fabric.
- 2.2 For Uniguard awnings, place screw through awning rail, polyrod and the soft connect material approximately 1" in from the end of the fabric.
- 2.3 For Alumaguard awnings, place screw on the outer edge of the Alumaguard (not through the Alumaguard).

## REMOVING THE TEMPORARY ASSEMBLY PINS

2 pins are inserted into the back of the left (idler) head for lateral stability during installation. Using a pair of pliers, remove and discard both pins.

**NOTE:** The awning will temporarily operate with the pins in place; however, for long term use the pins must be removed.

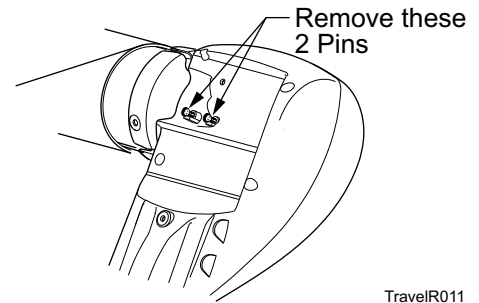

TravelR011

## INSTALLING THE TRACTIONERS

The tractioners are used with the Alumaguard and Uniguard metal fabric wraps.

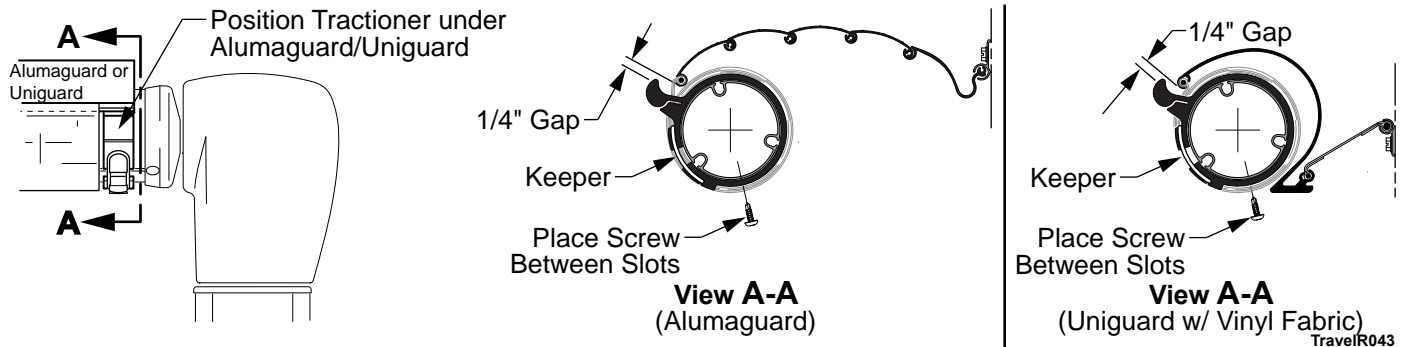

1. Partially extend the awning until the Alumaguard/Uniguard is extended as shown.
2. Unlock the keeper and wrap the tractioner around the roller tube.
3. Position the tractioner under the Alumaguard/Uniguard with a 1/4" gap between Alumaguard and tractioner. Lock the keeper.
4. Repeat for the other end of the rollbar.
5. Extend the awning to verify that the tractioners are lifting the metal wrap up and over the roller assembly.
6. To secure the tractioner, drill a 1/8" hole through the tractioner and roller tube, roughly center the hole between two slots of the roller tube.
7. Secure with one (1) #10 square drive screw.

## ATTACHING THE FASCIA

The fascia fits between the two struts of the lower arm.

1. If open, close the awning.
2. On the outer channels use a non-permanent method of marking and mark the bottom of the inner channel. Repeat for both arms.
3. Open the awning.
4. From behind, slip the fascia between the outer channels of the lower arm. Align the mounting dimples of the fascia with the mounting slots in the outer channels.
5. The fascia should sit approximately 1/8" below the marks made in step 2.
6. Press the fascia between the channels until the dimples snap into the slots.
7. Repeat for the other arm.

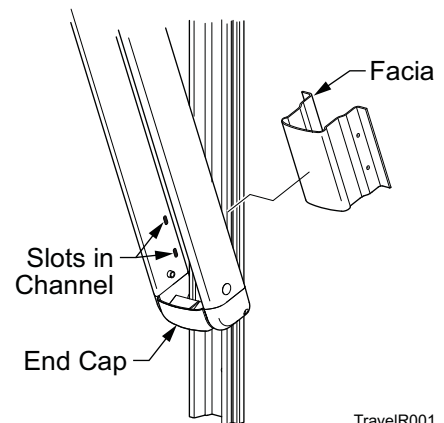

TravelR001

## LED SWITCH INSTALLATION (FACTORY INSTALLED OPTION)

These instructions are for the optional factory installed LEDs in the roller tube. For aftermarket LED Upgrades refer to: 052593-001, White LED Upgrade or 052594-001, RGB LED Upgrade.

### SPECIFICATIONS

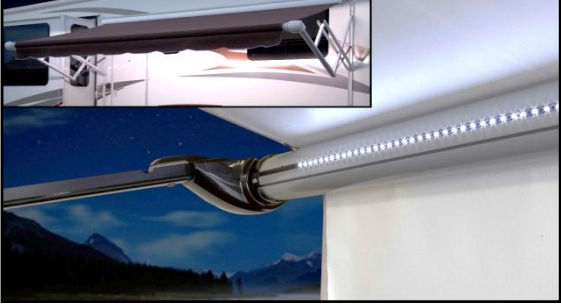
<b>MOUNTING:</b>	LED light strip is factory mounted in a specially designed roller tube. Wire is concealed in canopy hem.	 <p style="text-align: center;"><i>Shown on Carefree Eclipse Awning</i></p>
<b>LENGTH:</b>	Available for awnings 10' – 21'* * Maximum LED strip length is 16' 5". Strip is centered in roller tube for units longer than 18'	
<b>POWER:</b>	1A, 12VDC	
<b>CONTROLS:</b>	1. Single pole, single throw switch (SR0101)	
<p><i>Note: The Switch kit is ordered separately. Kit includes in-line fuse holder and 2A spade type fuse. For an installer furnished control switch, see note under "Switch Installation".</i></p>		

**NOTE:** For Travel'r and Eclipse installations, installers may choose to route the wire into the vehicle with the motor wires. Use "Wire Routing – Option 2".

### CAUTIONS:

- ⚠ The wire should be secured to the wall of the vehicle where it is exposed on the outside of the vehicle. Use a quality silicone sealant/adhesive.
- ⚠ Do not route the wire over sharp edges or heat sources that can cut or fray the wires or wire insulation.
- ⚠ Damage that is a result of improper routing may void warranty.

### Wire Routing – Option 1, Standard

1. Drill a 3/16" hole into the vehicle wall below the right edge of the canopy.
2. Route the wires from the canopy into the vehicle. Allow slack in the wire between the canopy and the wall. Seal the hole and wires with a quality silicone sealant.

### Wire Routing – Option 2, Motorized Awnings

1. After assembling the roller tube and arms per the awning instructions, route the canopy wire down the rear groove of the rear channel. Allow approximately 10 inches of cable between the canopy and arm.

**NOTE:** Cord retainers are not furnished with the awning. These may be ordered separately and used to secure the wire in the channel.

To use the retainers: Wrap the retainer around the wires. Press the retainer into the rear groove of the rear arm channel.

2. Route the wire down the rear channel groove to the desired awning motor cable entry point.
3. Route the LED wires into the vehicle with the awning motor wires.

**NOTE:** There is approximately 8 feet of wire from the wall entry point for upper wire routing, approximately 3 feet of wire from the wall entry point for lower wire routing. Controls should be located within this distance.

4. After the awning has been installed on the vehicle, route the wires along the bottom of the awning rail and secure.

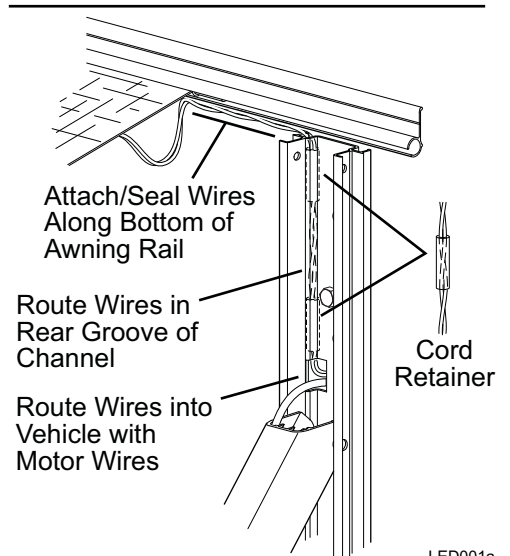
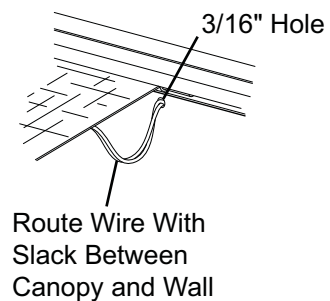

### SWITCH INSTALLATION

**NOTE:** Installers may choose to furnish the control switch. The installation requires that the power line (+12VDC) be attached to a dedicated 2A circuit breaker or a 2A in-line fuse must be installed between the switch and power source. Location of the fuse should be close to the switch for easy access.

1. Determine the location of the switch.
2. At the switch location, cut a 1 1/8" x 1 1/2" hole.
3. Wire the switch as shown below. Wire terminals at the switch are .187, 18-24 awg female disconnects.

**NOTE:** Allow adequate slack in the 12VDC power line so that the in-line fuse (installed in step 4) can be accessed from behind the switch.

4. Install the in-line fuse:
  - 4.1. Near the switch, cut the red 12VDC power line to the switch. Do not strip the insulation.
  - 4.2. Insert a wire end into one of the wire channels until it butts up against the stop.
  - 4.3. Fold that half of the connector body over until the element contacts the wire. Use pliers to crimp the connector closed.
  - 4.4. Repeat for the second wire end.
  - 4.5. Slide the fuse into the fuse port. Ensure that is firmly seated.
5. Press the in-line fuse, wires and switch into the mounting hole. Secure the switch using two (2) #6 x 1/2" screws.
6. Snap the switch bezel over the switch frame.

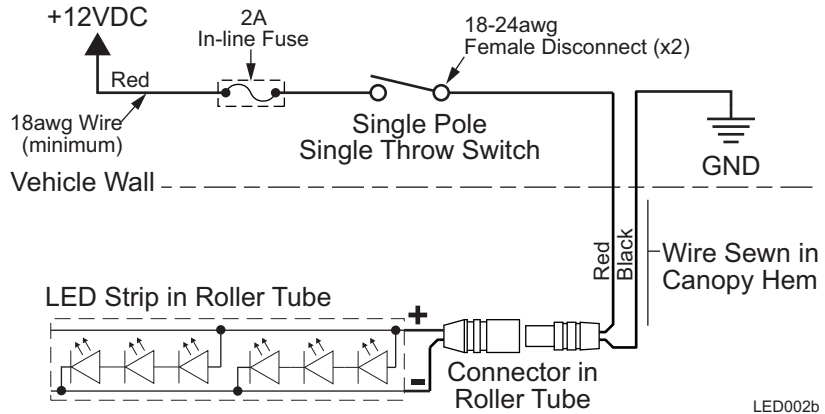
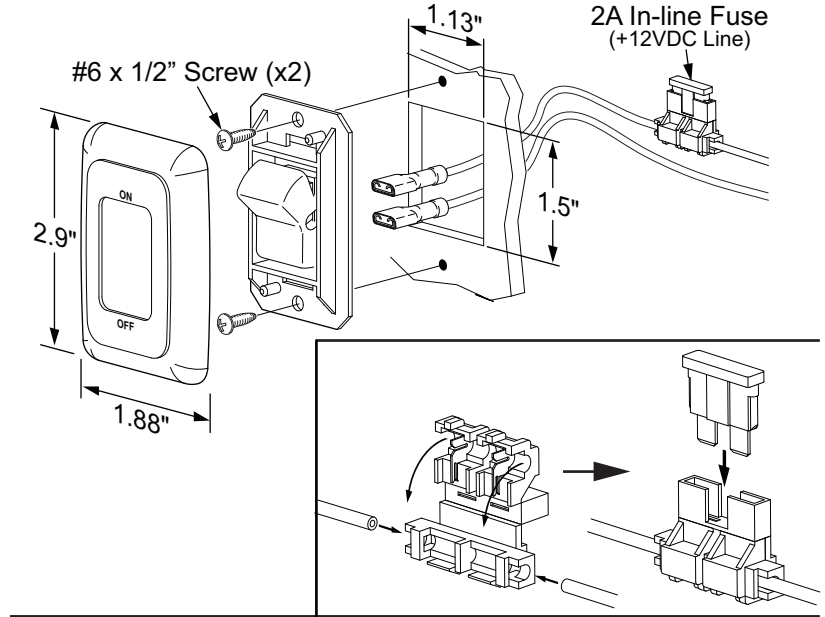



These modifications allows a Travel'r awning upgrade to use the existing A & E WeatherPro electronics.

**⚠ WARNING** THE WIND SENSOR AUTO RETRACT IS DISABLED AND WILL NOT RETRACT THE AWNING DURING INCLEMENT WEATHER.

**⚠ WARNING** THE AUTO EXTEND FEATURE **DOES NOT STOP** THE AWNING WHEN THE AWNING IS FULLY EXTENDED. IT IS NECESSARY TO PRESS THE BUTTON TO STOP THE AWNING WHEN FULLY EXTENDED. FAILURE TO STOP THE AWNING WILL ALLOW THE FABRIC TO REVERSE ROLL ONTO THE ROLLER TUBE.

1. When removing the existing WeatherPro Awning:
  - 1.1. Disconnect the sensor in the arm and remove the wind sensor and cable from the arm.
  - 1.2. Disconnect the motor cable and sensor cable connectors at the vehicle wall.
2. Mount the Carefree Travel'r Awning according to the installation instructions for the awning.
3. Motor Wires:
  - 3.1. On the new Travel'r motor wires, trim the wire and attach a mating connector that matches the existing WeatherPro connector. Ensure that the wire colors match (i.e. red to red and black to black).  
  
OR
  - 3.2. Cut off the existing connector from the wall cable and butt splice the new motor wires and the existing cable wires together and seal. Ensure that the wire colors match (i.e. red to red and black to black). Insert the connections into the wall.
4. Sensor:

**NOTE:** For the WeatherPro Electronics to function properly, the sensor must be attached to the control box. The sensor cannot be mounted in the Travel'r arm channel.

Option 1:

  - 4.1. Mount the sensor in an exposed area such as on the vehicle wall or roof above the awning.
  - 4.2. Attach the sensor to the control box.

Option 2:

  - 4.3. Pull the sensor cable through the wall to the control box.
  - 4.4. Reattach the sensor to the control box.
  - 4.5. Bundle the sensor and cable and secure in a discreet location (i.e. inside the wall).

*Tip: To avoid a large amount of cable, attach the sensor to the cable from the arm channel. Trim off the other end of the cable and install a 3 pin connector that can be connected to the control box.*
5. Plug and seal the wire entry holes.