



SERVICE MANUAL ECLIPSE 2015 & ON

THIS PUBLICATION COVERS THE FOLLOWING MODELS:

RV

- Universal Eclipse
- Eclipse w/ Direct Response Electronics

The information contained in the publication applies to all models listed. Details and procedures unique to a specific model are labeled appropriately.



LED Lighting

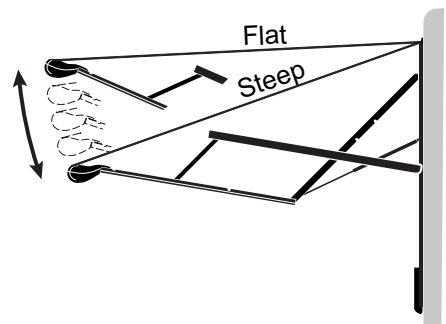

Adjustable Pitch

E0069

TABLE OF CONTENTS

Product Overview	1
<u>Eclipse Patio Awning Specifications:</u>	1
Canopy Replacement	2
Installing the Tractioners.....	5
Motor Replacement	6
Replacing the Motor - Awning Extended	6
Replacing the Motor –Awning Closed.....	8
Replacing the Gas Shock	10
Replacing the Arm Rollers	11
Diagnostics	12
Standard Electrical.....	13
Auto Retract Systems	16
Common Test Procedures.....	19
Wiring Diagram - Single Switch Prior to July 2010	21
Wiring Diagram - Single Switch - July 2010 and on.....	21
Wiring Diagram - Multiple Switch Prior to July 2010.....	22
Wiring Diagram - Multiple Switch After July 2010.....	22
Wiring Diagram - WindSmart.....	23
Wiring Diagram - Direct Response prior to July 2010.....	24
Wiring Diagram - Direct Response After July 2010	26
Wiring Diagram - Direct Response w/ Pre Wired Harness	27
LED Lighting	29
Switch Installation.....	29
Replacing the LED Strip	30
Canopy Harness Replacement.....	31
Attaching the Harness to Fabric Wrap.....	31
Standard Service Procedures	33
Programming the Remote Receiver	33
Operational Notes:.....	33
Battery Replacement.....	34
Charging the Battery	34
Standard Maintenance	35
Fabric Care.....	35
Mildew	35
Pooling	35
Arm Care	35
Hardware Maintenance	35
Motor Maintenance.....	35
Emergency Operation.....	36
Part Number Listing	37
Part Number/Serial Number Location.....	37
Arms Part Number Configuration.....	37
Roller Part Number Configuration.....	37
Illustrated Parts List.....	38
Arms.....	38
Electronics.....	40

PROPRIETARY STATEMENT

The Eclipse Patio Awning is a product of Carefree of Colorado, located in Broomfield, Colorado, USA. The information contained in or disclosed in this document is considered proprietary to Carefree of Colorado. Every effort has been made to ensure that the information presented in the document is accurate and complete. However, Carefree of Colorado assumes no liability for errors or for any damages that result from the use of this document.

The information contained in this manual pertains to the current configuration of the models listed on the title page. Earlier model configurations may differ from the information given. Carefree of Colorado reserves the right to cancel, change, alter or add any parts and assemblies, described in this manual, without prior notice.

Carefree of Colorado agrees to allow the reproduction of this document for use with Carefree of Colorado products only. Any other reproduction or translation of this document in whole or part is strictly prohibited without prior written approval from Carefree of Colorado.

SAFETY INFORMATION

⚠ WARNING A WARNING INDICATES A POTENTIALLY HAZARDOUS SITUATION WHICH, IF NOT AVOIDED, COULD RESULT IN DEATH OR SERIOUS INJURY AND/OR MAJOR PROPERTY DAMAGE.

⚠ CAUTION A caution indicates a potentially hazardous situation that may cause minor to moderate personal injury and/or property damage. It may also be used to alert against unsafe practices.

NOTE: A note indicates further information about a product, part, or step.

Tip: A tip provides helpful suggestions.

Safety Notes:

- To avoid shock hazard and/or accidental system shorting, always disconnect battery or power source before working on or around the electrical system.
- Always wear appropriate safety equipment (i.e. goggles).
- Awnings have significant weight. Always use appropriate lifting devices and/or helpers when lifting or holding heavy objects.
- When using fasteners, use care to not over tighten. Soft materials such as fiberglass and aluminum can be "stripped out" and lose the ability to grip and hold.

PRODUCT OVERVIEW

The Eclipse Patio Awning uses unique “scissor” style arms that do not require vertical ground support. The arms provide easy to use pitch adjustment—simply push together the pins on the arms, snap into the hole set desired, and the pitch is set! The pitch can be left in any position and the Eclipse will roll up completely! When the awning is rolled back out, it rolls out to the pitch setting previously set.

The awning roller tube and arms are made from light weight, no-rust aluminum. The awning fabric is offered in either heavy weight vinyl or the Sunbrella® fabric, one of the most durable, strongest, weather-resistant and fade resistant fabrics on the market.

The Direct Response auto-retract system is used for the hardwired Eclipse awning. The system may be installed as part of the original motorized awning installation or as an upgrade to an existing motorized awning. An auto-retract system offer unique features not available with standard electronics:

- *Full-Extend* – Press and release the control to extend, the awning extends completely. It is not necessary to hold the button when opening.
- *Full-Retract* – Press and release the control to retract, the awning retracts completely. It is not necessary to hold the button when closing.
- *Auto-Retract* – The awning can be set to automatically close when windy conditions occur.
- *Remote Control* – The operator can conveniently operate the awning from any location with a wireless remote control.

Eclipse Patio Awning Specifications:

LENGTH	12' - 21' [366 - 640cm]		
EXTENSION:	7' 6 3/4" [230.5cm]	Drop @ Min. Pitch: 12" [30.5cm]	Drop @ Max. Pitch: 40" [102cm]
<i>Values are approximate, actual dimensions may vary with specific installations.</i>			
EXTENSION TIME:	28 Seconds (approx)	RETRACTION TIME:	32 Seconds (approx)
POWER REQUIREMENTS:	12VDC (operating range 10VDC to 14VDC) Circuit Rating: 15 amp		
POWER SOURCE:	Motor and controls are routed and hardwired into the vehicle's 12V system		
EMERGENCY RETRACT:	Electrical override system (external power source)		
COLOR:	<i>Hardware:</i>	White, Black or Satin	
	<i>Fabric:</i>	Heavy Duty Vinyl or Acrylic Fabric with Alumaguard or Uniguard <i>(refer to sales literature for colors)</i>	
	<i>Fabric Wrap:</i>	Weatherguard, FLXguard or Metal Wraps: Alumaguard or Uniguard	

CANOPY REPLACEMENT

1. Remove the canopy retaining screws in the awning rail.
2. Extend the awning out completely.
3. For awnings with LEDs in the roller tube:
 - 3.1. On the motor side, remove the split grommet from the roller tube.
 - 3.2. Carefully pull the wires and connectors out of the roller tube. Disconnect the connectors.
 - 3.3. Clamp the LED harness connector outside the roller tube to prevent it from falling back into the roller tube. This can be done with a paper clip or similar device that will not damage the wires.
 - 3.4. At the awning rail, clip the harness close to the canopy. Clamp the harness going into the vehicle to prevent it from falling in the wall.

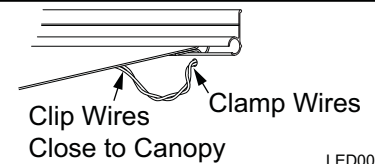
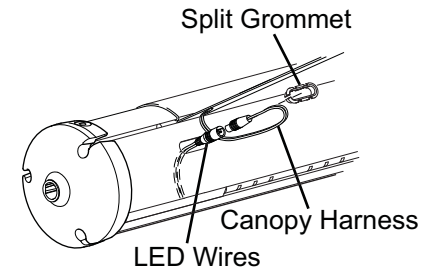

LED006a

4. Remove the screws that attach the end caps to the roller tube and save.
5. While holding the roller tube up, pull the roller tube out of the end cap of the motor head.

⚠ CAUTION Do not allow the roller tube to drop toward the ground. The twisting motion can cause serious damage to the idler arm.

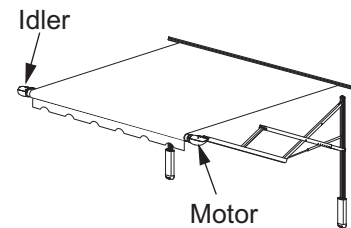

6. Support the roller tube; pull the roller tube out of the end cap of the idler head.
7. Allow the fabric and roller tube to hang down on the side of the RV. Use care to not scratch the side of the RV.
8. Mark the slots that the current fabric is in then remove any fabric retaining screws in the roller tube and tractioners used with Alumaguard. Slide the roller tube off the fabric.

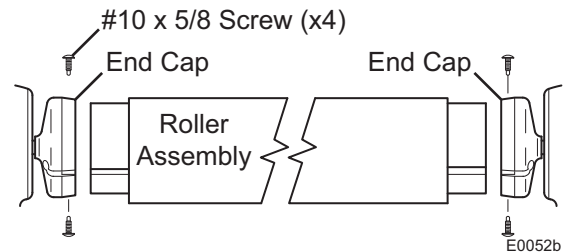

E0052b

9. Determine the type of canopy replacement:

- If replacing a full fabric canopy or canopy with Alumaguard or canopy with Uniguard: For arms using an upper mounting bracket, it will be necessary to remove the upper bracket from one side. After removing the bracket brace the arm using scaffolding or similar support.

⚠ CAUTION The lower mounting screws for arms using the upper bracket may not be mounted into structural members of the vehicle wall. Failure to support the arm can result in damage to the vehicle wall.

- For canopy only replacement for units with Alumaguard: The fabric is crimped into the aluminum slat. Use a large flat screw driver or similar tool to spread open the crimp on both sides of the fabric.
- For canopy only replacement for units with Uniguard: Remove the retaining screws from both sides of the Uniguard.
- For canopies with LEDs at the awning rail: Disconnect the LED strip from the harness for white LEDs or from the controller for RGB applications.

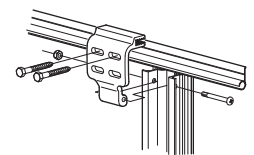

Upper Bracket
(After Market Installations)

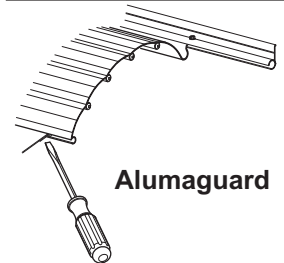

Alumaguard

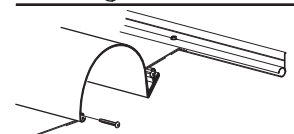

Uniguard TravelR014b

10. Slide the fabric out of the awning rail or metal wrap.
11. For canopies with LEDs at the awning rail: Slide the canopy and LED rail adaptor out of the awning rail.

12. Clean and deburr the roller tube slots and awning rail/Alumaguard/Uniguard as required. If not previously done, spread open the awning rail track to facilitate inserting the new fabric.

Tip: Lightly spraying the slots with a dry silicone lubricant will help the fabric slide into the slot without staining the material.

13. Unfold the replacement fabric

13.1. Slide the new fabric into the awning rail/Alumaguard/Uniguard.

13.1.1. For Alumaguard: Center the fabric, use a pair of side cutters or similar tool and crimp the aluminum. Use care to not bend or distort the aluminum slats.

13.1.2. For Uniguard: Center the fabric and install the fabric retaining screws removed previously.

13.1.3. Allow the fabric to hang down the side of the coach.

13.2. For canopies with LEDs at the awning rail:

13.2.1. Carefully remove the staples from the rail adaptor and old canopy.

13.2.2. Slide the rail adaptor with LEDs onto the new fabric and secure with staples. Ensure that the staples are flush on the top and bottom.

13.2.3. Slide the canopy and rail adaptor into the awning rail. Center the fabric and install any fabric retaining screws removed previously

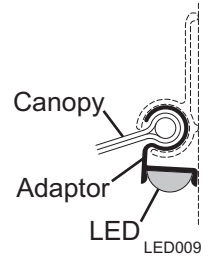

NOTE: While the awning fabric is fairly robust, care must be taken not to snag it on the awning rail.

14. If removed, install the upper mounting bracket.

15. Position the fabric feeders on the roller tube. Be sure to use the same slots as the old canopy.

16. Slide the roller tube on to the new fabric.

17. Remove the feeders.

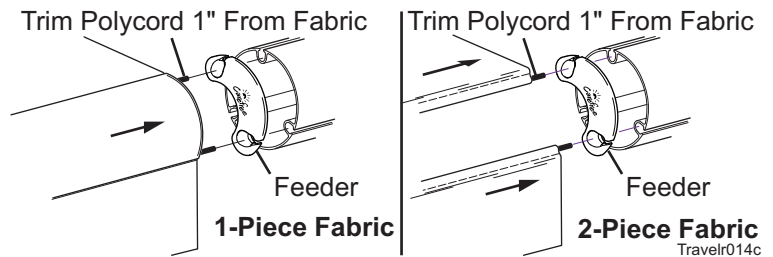

18. Lift and align the roller assembly with the end cap on the motorized arm assembly. Rotate the end cap until the slot in the cap aligns with the empty slot in the roller tube; press the roller assembly fully into the cap. The end cap must seat squarely over the end of the roller tube.

NOTE: The roller assembly must be oriented with the fabric going over the roller toward the vehicle wall.

19. Secure the end cap to the roller tube using two #10 square-drive screws.

20. Repeat to attach the idler arm assembly to the roller tube.

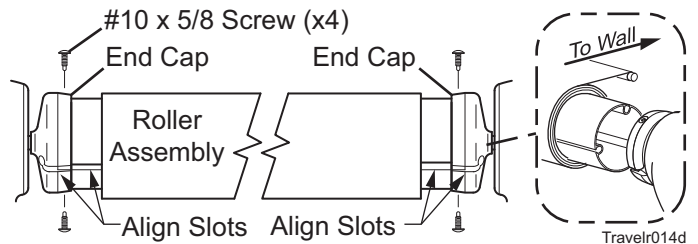

21. Check that the fabric is properly positioned. Adjust as required.

- 21.1. For vinyl canopies: Center the fabric on the roller tube. install the fabric retaining screws removed previously.
- 21.2. For acrylic canopies: The canopy is flared (tapered) only on the motor side. The canopy is NOT centered in the roller tube. The LH (idler) edge of the canopy should be parallel to the centerline of the idler arm leaving a larger space between the roller end cap and fabric on the motor side. Install the fabric retaining screws removed previously.

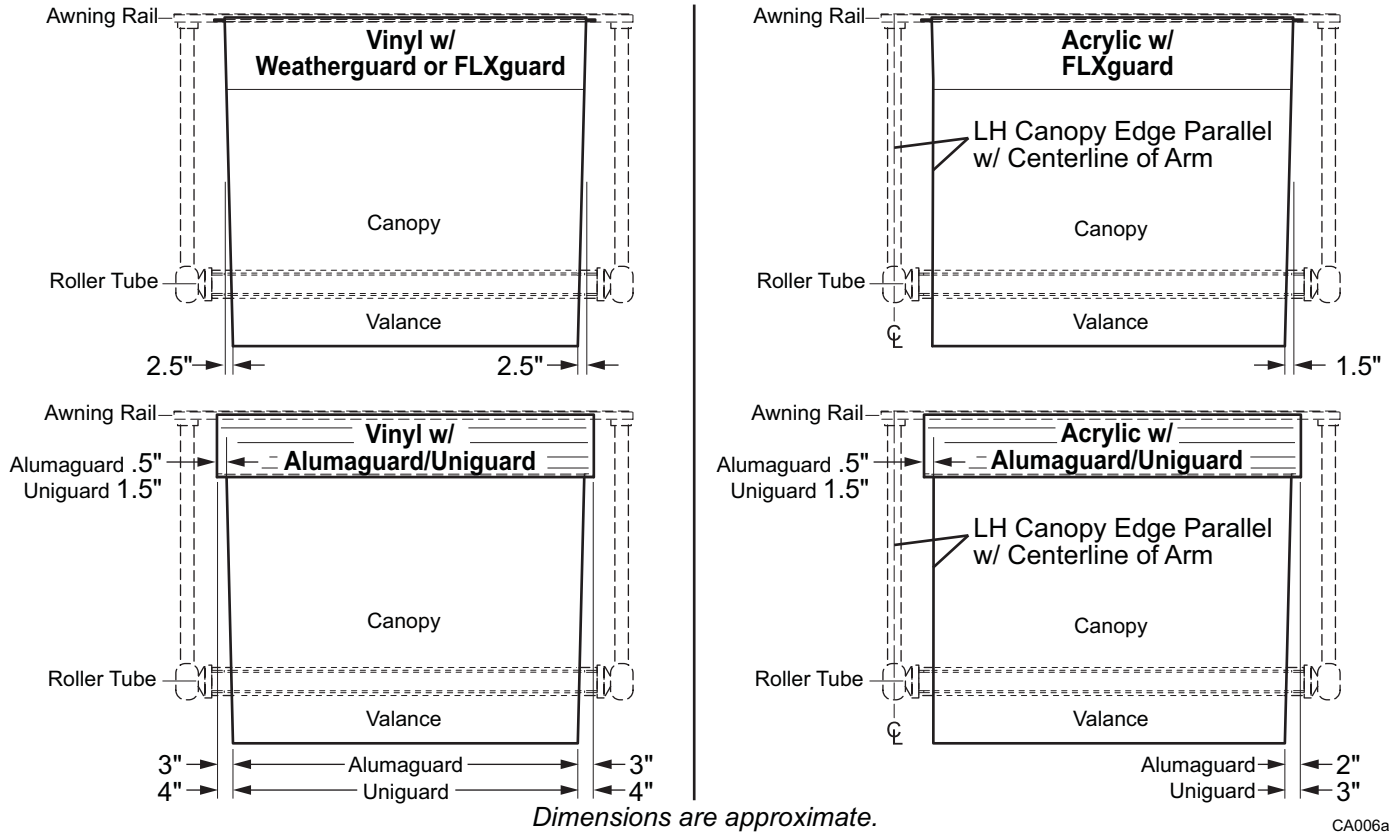

CA006a

22. Roll the awning in and out several times to make sure that the fabric rolls squarely on the roller tube.

23. Secure the canopy to the awning rail using one, #6 x 3/8" hex head screw at both sides of the awning.

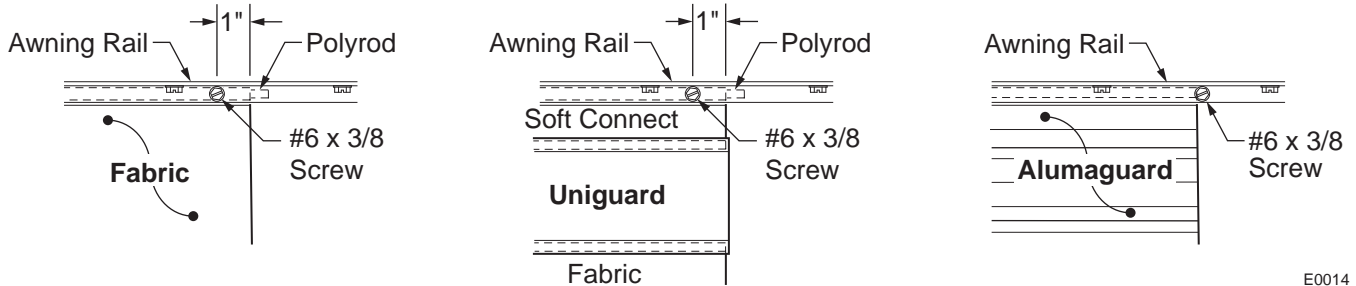

E0014

- 23.1. For vinyl awnings, place screw through awning rail, polyrod and canopy approximately 1" in from the end of the fabric.
- 23.2. For Uniguard awnings, place screw through awning rail, polyrod and the soft connect material approximately 1" in from the end of the fabric.
- 23.3. For Alumaguard awnings, place screw on the outer edge of the Alumaguard (not through the Alumaguard).

24. For awnings with LEDs in the roller tube:

- 24.1. Connect the canopy harness connector and LED connector. Then carefully push the connectors into the roller tube.
- 24.2. Place the split grommet over the canopy harness and press the grommet into the hole of the roller tube.
- 24.3. If the canopy has a metal wrap, attach the wire to the inside of the wrap (see page 31) then proceed with the next step.
- 24.4. At the vehicle wall, route the new canopy harness through the wall to the switch.
Tip: Tie the new harness to the old harness that was cut previously. Use the old harness to pull the new harness through the wall to the desired location.
- 24.5. At the vehicle wall, provide a 3" loop of harness between the canopy and wall. Seal the wall entrance hole and harness with a quality silicone sealant.
- 24.6. Connect the new harness to the switch. Two (2) .187, 18-24 awg female disconnects are provided if connecting to a switch.
- 24.7. **Alternate method:** At the wall, splice the new harness to the existing harness using 24 awg butt connectors. Push the connectors into the vehicle wall. Seal the wall entrance hole and wires with a quality silicone sealant.

NOTE: Be sure to allow enough harness from the canopy to provide a 3" loop of harness and adequate length for the connectors to be pushed inside the wall before sealing the hole and harness with a quality silicone sealant.

25. For canopies with LEDs at the awning rail: Connect the LED strip to the harness for white LEDs or to the controller for RGB applications.

For Alumaguard/Uniguard installations, go to "Installing the Tractioners".

INSTALLING THE TRACTIONERS

The tractioners are used with the alumaguard metal fabric wrap and uniguard with vinyl fabrics.

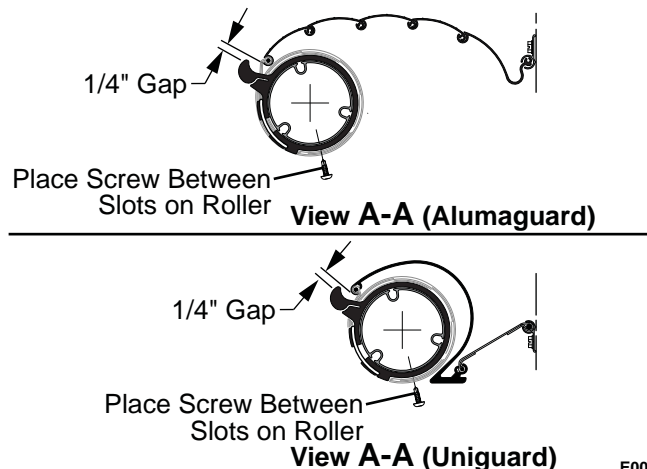
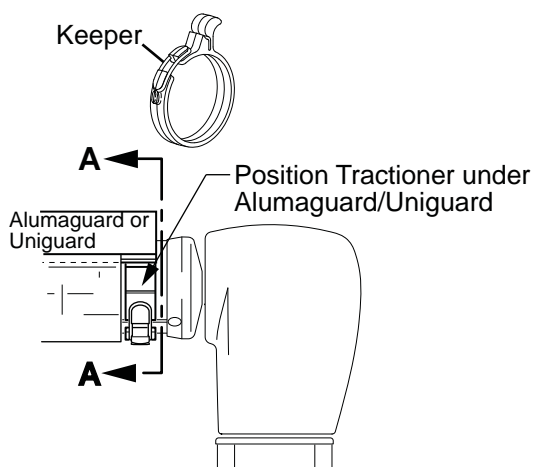

E0058

1. Partially extend the awning until the Alumaguard/Uniguard is extended with the edge on the roll bar as shown.
2. Unlock the keeper and wrap the tractioner around the roller tube.
3. Position the tractioner under the Alumaguard/Uniguard with a 1/4" gap between the metal wrap and tractioner. Lock the keeper.
4. Repeat for the other end of the roller tube.
5. Extend the awning to verify that the tractioners are lifting the metal wrap up and over the roller assembly.
6. To secure the tractioner, drill a 1/8" hole through the tractioner and roller tube; roughly center the hole between two slots of the roller tube.
7. Secure with one (1) #10 square drive screw.

MOTOR REPLACEMENT

⚠️WARNING TO AVOID SHOCK HAZARD AND/OR ACCIDENTAL SYSTEM SHORTING, ALWAYS DISCONNECT THE VEHICLE BATTERY AND ELECTRICAL SOURCES BEFORE WORKING WITH ELECTRICAL WIRING AND COMPONENTS.

Two methods are used for replacing the Eclipse motor. 1) Replacing the motor if the awning is extended (fully or partially) and 2) Replacing the motor if the awning is fully closed.

REPLACING THE MOTOR - AWNING EXTENDED

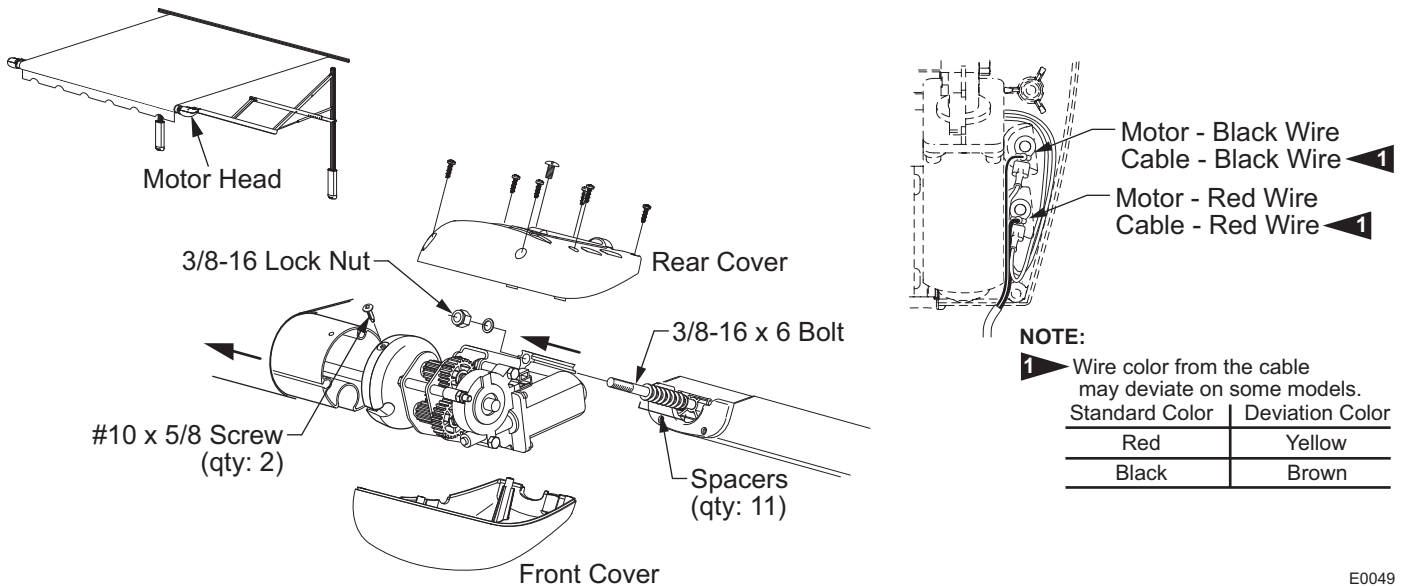

Figure 1. Motor Replacement - Awning Extended.

1. For convenience, lower the awning to the maximum pitch setting.
2. On the motorized side, remove the two square drive screws attaching the end cap to the roll bar then separate the roll bar from the end cap. It will be necessary to hold the roll bar and both arms in position.

⚠️CAUTION The arms are under tension from the gas shocks. When the motor is disengaged from the gears, the roller tube will be able to free spin and both arms will extend from the gas shock tension. Use extreme care and hold the arms in position. It will be necessary to have at least one other person holding the idler arm.

3. Hold on to the motor arm and allow it to extend to its maximum position.
4. Hold on to the idler arm and roll bar and allow the arm to extend to its maximum position while allowing the fabric to unroll from the roll bar.
5. Use a ladder or other device support the roll bar.

⚠️CAUTION Do not allow the roll bar to drop toward the ground. The twisting motion can cause serious damage to the idler arm.

6. On the right hand arm remove the front cover by removing the six (6) smaller screws from the back of the motor head. Save cover and screws.
7. Disconnect the motor and cable wires from inside the rear cover. Carefully note the location of each wire.
8. Remove the rear cover by removing the one (1) large screw from the back of the motor head. Save cover and screw.
9. Loosen and remove the 3/8-16 lock nut from the mounting bolt. Make note of the number and order of the spacer-washers between the arm mounting block and the motor head.

Tip: When the nut is removed, the bolt will slide out of the arm mounting block inside the arm channel. Placing tape on the head of the mounting bolt and the spacers will prevent them from falling out when the nut and motor are removed.

10. Remove the motor assembly. The motor assembly consists of the motor, mounting frame, gears, shaft and roller end cap.
11. Place the new motor assembly in position over the mounting bolt. Ensure that the spacer-washers are all accounted for.
12. Secure using the washer and lock nut removed previously. The nut should be tightened until snug but the motor head should be able to swivel by hand.
13. Attach the rear cover to the motor assembly using the large screw removed previously.
14. Attach the motor and cable wires to the terminals inside the rear cover.
15. Align the roll bar with the end cap on the motorized arm assembly. Rotate the end cap until the slot in the cap aligns with the empty slot in the roller assembly, and then press the roller assembly fully into the cap. The end cap must seat squarely over the end of the roller assembly when complete.
NOTE: On early units, a spider gear inside the end cap is used to hold the roller tube in position with the drive shaft. The replacement end cap no longer requires the use of the spider.
16. Secure the end cap to the roller assembly using two #10 x 5/8 square-drive screws.
17. Restore power and test operation. If the awning moves in the wrong direction (i.e. extends when retract is pushed) reverse only the two motor wires in the rear cover.
18. Attach the front cover using the small screws removed previously.

REPLACING THE MOTOR –AWNING CLOSED

This procedure will require replacing the front and rear motor covers in addition to the motor assembly.

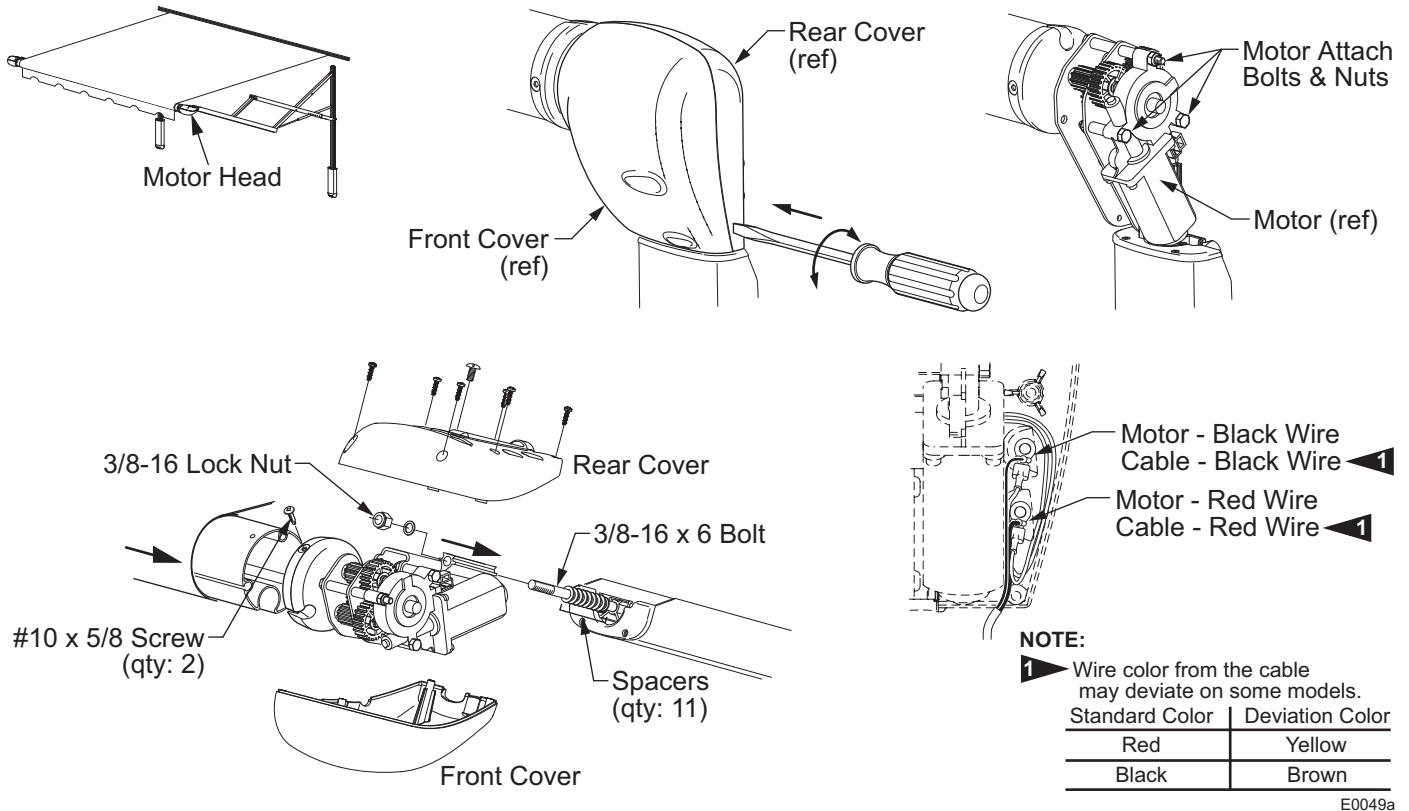

Figure 2. Motor Replacement - Awning Closed.

1. Place a large flat blade screwdriver or similar tool in the seam between the front and rear covers. Using a twisting and prying motion, break the covers off. It may be necessary to use a hammer and lightly tap the screwdriver into the plastic to establish a starting point.

Tip: Start at the bottom and work around the seam until the covers are off.

2. Disconnect the motor and cable wires from inside the rear cover. Carefully note the location of each wire.
3. Firmly hold the motor and idler arms up while removing the three (3) motor attach bolts and nuts.
4. Remove the motor from the motor mounting frame.

⚠CAUTION The arms are under tension from the gas shocks. When the motor is disengaged from the gears, the roller tube will be able to free spin and **both** arms will extend from the gas shock tension. Use extreme care and hold the arms in position. It will be necessary to have at least one other person holding the idler arm.

5. While holding on to the arms and roll bar allow the awning to extend to the maximum position; the fabric will unroll from the roll bar.
6. On the right hand arm remove any pieces of the front and rear covers. Remove the cover's attaching screws and save.
7. Remove the two square drive screws attaching the end cap to the roll bar, separate the roll bar and end cap. It will be necessary to hold the roll bar and motor arm. Allow the arm to extend out.
8. Use a ladder or other device support the roll bar.

⚠CAUTION Do not allow the roller tube to drop toward the ground. The twisting motion can cause serious damage to the idler arm.

9. Loosen and remove the 3/8-16 lock nut from the mounting bolt. Make note of the number and order of the spacer-washers between the arm mounting block and the motor head.

Tip: When the nut is removed, the bolt will slide out of the arm mounting block inside the arm channel. Placing tape on the head of the mounting bolt and the spacers will prevent the bolt and the spacers from falling out when the nut and motor are removed.

10. Remove the rest of the motor assembly. The motor assembly consists of the motor, mounting frame, gears, shaft and roller end cap.
11. Place the new motor assembly in position over the mounting bolt. Ensure that the spacer-washers are all accounted for.
12. Secure using the washer and lock nut removed previously. The nut should be tightened until snug but the motor head should be able to swivel by hand.
13. Attach the rear cover to the motor assembly using the large screw removed previously.
14. Attach the motor and cable wires to the terminals inside the rear cover.
15. Align the roll bar with the end cap on the motorized arm assembly. Rotate the end cap until the slot in the cap aligns with the empty slot in the roller assembly, and then press the roller assembly fully into the cap. The end cap must seat squarely over the end of the roller assembly when complete.
NOTE: On early units, a spider gear was inside the end cap to hold the roller tube in position with the drive shaft. The replacement end cap no longer requires the use of the spider.
16. Secure the end cap to the roller assembly using two #10 x 5/8 square-drive screws.
17. Restore power and test operation. If the awning moves in the wrong direction (i.e. extends when retract is pushed) reverse only the two motor wires in the rear cover.
18. Attach the front cover using the small screws removed previously.

REPLACING THE GAS SHOCK

⚠CAUTION The gas shock has approximately 85 lbs. of pressure in the closed position. A pressurized shock can open rapidly when removed or released causing personal injury and property damage.

1. Open the awning.

NOTE: The arm may not completely open when the shock has lost pressure or it is removed. It may be necessary to pull the arm out and away from the vehicle to open the awning.

2. Remove the stop bolts and save.
3. Remove the two square drive screws attaching the end cap to the roller tube, then separate the roller tube and end cap. It will be necessary to hold the roll bar and motor arm. Allow the arm to extend out.
4. Use a scaffold or similar device to support the roller tube.

⚠CAUTION Do not allow the roller tube to drop toward the ground. The twisting motion can cause serious damage to the idler arm.

5. Support the arm in the area shown.
6. Unscrew the shock barrel from the clevis in the mounting channel.

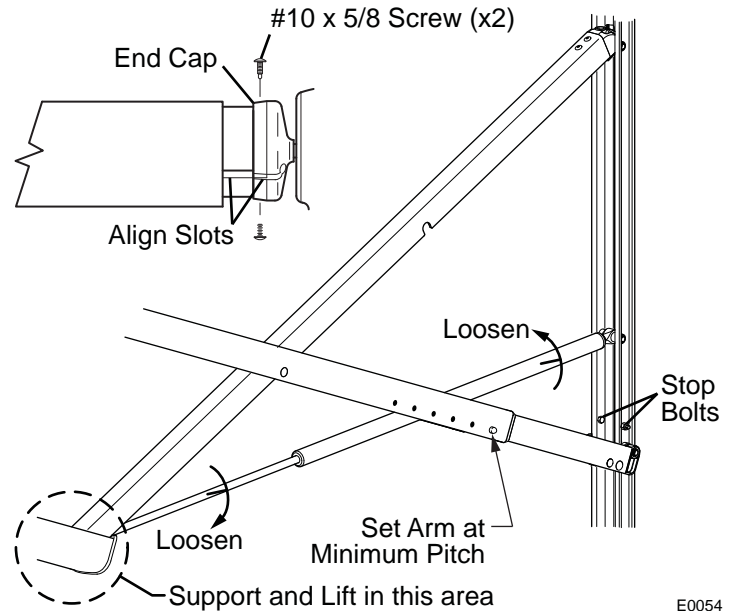

E0054

Tip: Wearing a pair of rubber gloves will aid in gripping the surfaces of the shock.

7. Unscrew the shaft from the clevis in the arm joint. Set old shock aside.

NOTE: It may be necessary to use vice grips or pliers on the old shock to unscrew the shock from the clevis. DO NOT use vice grips or pliers on the new shock. Damage to the surface of the shaft or damage to the barrel can cause the new shock to not work.
8. Unpack the new shock and carefully allow it to extend to its maximum length.
9. Insert the new shock between the upright struts.
10. Coat the threads of the shaft of the new shock with a non-permanent thread lock (i.e. loctite) then screw the rod into the clevis of the arm elbow. Hand-tighten only.
11. Lift and hold the arm up in the area indicated in Figure 9. The arm should be unfolded and extended as far as possible.
12. Coat the threads of the barrel of the new shock with a non-permanent thread lock (i.e. loctite) then screw the barrel into the clevis in the mounting channel. Hand-tighten only. It will be necessary to grip and hold the shaft while turning the barrel.
13. Align the roll bar with the end cap on the arm assembly. Rotate the end cap until the slot in the cap aligns with the empty slot in the roller assembly, and then press the roller assembly fully into the cap. The end cap must seat squarely over the end of the roller assembly when complete.
14. Secure the end cap to the roller assembly using two #10 x 5/8 square-drive screws.
15. Partially retract the awning. It may be necessary to lightly pull down on the lower arm at the mounting channel until the rollers are past the location of the stop bolts. Always pull down from the bottom of the arm to avoid pinching.
16. Reinstall the stop bolts removed in step 2.

REPLACING THE ARM ROLLERS

Use Kit number R019291-005 for white or R019251-006 for black.

1. Open the awning completely.
2. Use a ladder or scaffold to support the roller tube.
3. Disconnect power to the awning.
4. Cut the tie bracket in half.
5. Drill out the roll rivets from the roller on both sides of the arm. Drill only the rivet; do not drill into the roller mount at the bottom of the channel.

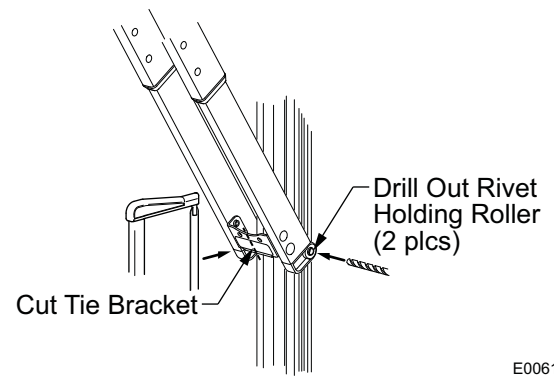

E0061a

6. Spread the arm channels and hold slightly skewed. From inside the channels, drill out the 4 rivets that hold the tie bracket halves. Remove and discard parts.
7. Pull out the roller from the channel. It may be necessary to use a flat blade screwdriver or similar tool to "pop out" the roller.

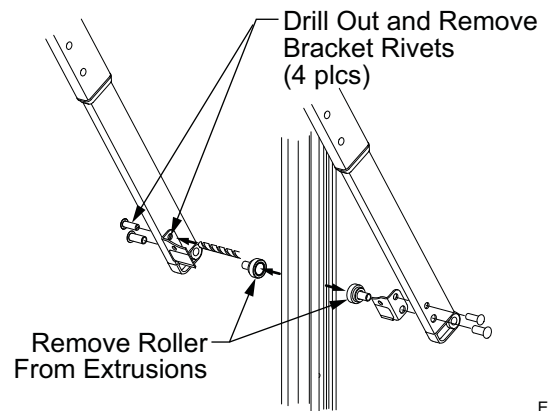

E0061b

⚠ CAUTION USE A RAG OR SIMILAR PROTECTION BETWEEN ANY TOOLS AND THE SURFACES OF THE ARMS. THIS IS TO PREVENT SCRATCHING OR DAMAGING THE SURFACE.

8. Assemble the new roller, standoff and rivet as shown then insert the roller into the channel of the extrusion. It may be useful to use a clamp or wide mouth pair of pliers to squeeze the new roller into the channel of the extrusion.
9. Slide the arm channels onto the rivets.

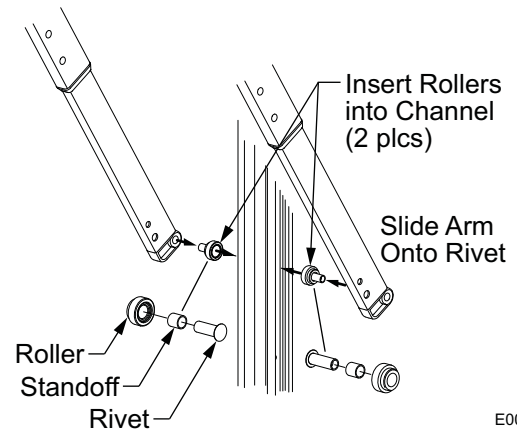

E0061c

10. Position the new tie bracket between the arm channels.
11. Attach using four (4) each 1/4-20 x 1 truss head screws and nylock nuts. Use the existing rivet holes in the channels. Before tightening, make sure that the front of the bracket is parallel with the front face of the channels.
12. Clean the surface of the bracket then attach the warning label to the front of the bracket.
13. Remove the roller tube supports and reconnect power to the awning.

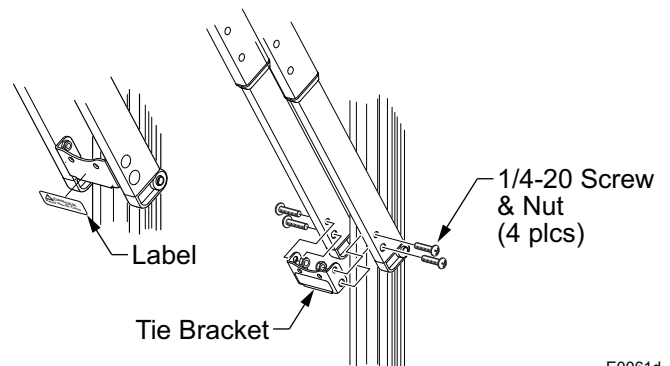

E0061d

DIAGNOSTICS

The following procedures are intended to aid the service technician to logically resolve operational issues with the mechanical and standard electronics installations.

Common Operational Items

The following items are operational items that may come up as questions during normal operation. These are also given in the operator's manual.

1. The motor has a thermal protection circuit. If the motor overheats, the circuit will shut off the motor. Wait approximately 15 minutes, operation will return to normal. As an example, this may occur if the awning is fully closed and retract switch pushed repeatedly, then the awning does not extend.
2. The awning seems to extend and retract slowly. The operational range is 28-35 seconds to extend or retract. If the power supply is on the low side of the range (10V) the awning will move slower.
3. The awning may appear to move jerkily. When the fabric is rolled out, the Alumaguard or Uniguard may "bounce" creating a wave like motion in the canopy fabric. This will create the appearance of moving jerkily.
4. With Uniguard, the awning sticks or hangs up. When Uniguard is installed with a vinyl canopy, the vinyl will have a tendency to "cling" to the Uniguard when not used over an extended period. Open and close the awning in short bursts 2 or 3 times, the awning will then open normally.

Refer to the appropriate wiring diagram for the system being tested:

STANDARD ELECTRICAL

- Wiring diagram – single switch page 21
- Wiring diagram – multiple switch page 21

AUTO RETRACT SYSTEMS:

- Wiring diagram – Windsmart page 23
- Wiring diagram – Direct Response page 24

Procedures in this section: ***Page***

STANDARD ELECTRICAL.....	13
D01 THE AWNING OPERATES IN REVERSE OF THE SWITCH PLATE	13
D02 THE AWNING DOES NOT EXTEND AND/OR RETRACT	13
D03 ARM DOES NOT EXTEND OR DOES NOT EXTEND COMPLETELY	15
AUTO RETRACT SYSTEMS	16
D04 THE AWNING OPERATES IN REVERSE OF THE SWITCH PLATE MARKINGS	16
D05 THE AWNING DOES NOT EXTEND AND/OR RETRACT USING THE PATIO SWITCH.....	16
D06A AWNING DOES NOT AUTO-RETRACT DURING WINDY CONDITIONS -WINDSMART	17
D06B AWNING DOES NOT AUTO-RETRACT DURING WINDY CONDITIONS –DIRECT RESPONSE	17
D07 AWNING DOES NOT MOVE WHEN KEY FOB BUTTONS ARE PUSHED	18
COMMON TEST PROCEDURES	19
CT01 TESTING A SWITCH AND HARNESS	19
CT02 TESTING THE CONTROL BOX	20
CT03 TESTING THE BATTERY AND CHARGER	20

STANDARD ELECTRICAL

The following procedures are intended to aid the service technician to logically resolve operational issues with the mechanical and standard electronics installations.

In the charts below, YES is a positive response to the test; NO is a negative response.

D01 THE AWNING OPERATES IN REVERSE OF THE SWITCH PLATE			
<i>This condition generally occurs during new installations or when major components have been replaced.</i>			
A	Confirm Switch is mounted in correct position and correctly oriented.	YES	Switch mounted OK; go to test B
		NO	Carefully remove the switch, rotate 180 and reinstall in panel. Reconnect harnesses and retest
B	Confirm switch is wired correctly. Use the wiring diagram and confirm the wires to/from the switch to the connector are correctly placed.	YES	Switch wired OK; go to test C
		NO	Rewire the switch according to the wiring diagram

D02 THE AWNING DOES NOT EXTEND AND/OR RETRACT			
<i>For Multiple Switch configurations, the Power switch must be ON.</i>			
A	Check Installation Integrity Use the wiring diagram and confirm that the components and wiring are properly installed and connected	YES	Go to test B
		NO	Correct as required
B	Confirm Power Supply Is vehicle battery or power source providing 10V to 14V to the Switch (Power switch for Multiple switch installations) For battery installations, use test procedure "CT03 Testing the Battery" on page 20.	YES	Go to test B
		NO	Correct as required
C	Test Motor Function 1. For installations with an external plug; Disconnect plug. 2. For installations with a single switch; Remove switch plate and disconnect the motor wires from the switch. 3. For installations with multiple switches, disconnect the connector from the relay to the motor. If no connector, remove the butt splices on the red and black wires from the motor. Cap the wires to prevent shorting 4. Attach jumper leads to the emergency terminals located on the back of the motor head. 5. Connect the other ends of the jumpers to a 12-18VDC power source (i.e. drill battery). It may be necessary to try then reverse the leads on the battery and try again. 6. Does the motor run?	YES	Motor is good, go to test C
		NO	Motor is defective - replace
D	Test wire continuity between motor and wire ends.	YES	Wire continuity good – reconnect the wires disconnected in the previous test then go to test E
		NO	Repair as required then reconnect the wires disconnected in the previous test.

DO2 continued on next page

D02 (CONT)

E Test Switch Function – Single Switch Installation (this test requires a continuity tester)
The Patio Switch used in the Single Switch Installation is a center on that is internally cross-wired to short in the center position to provide dynamic braking for the motor to prevent "drift" when the awning is stopped.

Test 1 is for Series I & II switches. Use Test 2 for Series III switches.

Observe continuity for switch in center position, extend position and retract position.

1a Place one lead of tester on pin 2B. Touch 2nd lead to the other pins one at a time.	Pin:	Center	Extend	Retract	YES	Test OK, all checks pass – go to step 1b
	3	N	Y	N		
	6	Y	N	Y	NO	Test failed; switch defective - replace
	5B	Y	N	N		
N = no continuity, Y = continuity						

1b Place one lead of tester on pin 5B. Touch 2nd lead to the other pins one at a time.	Pin:	Center	Extend	Retract	YES	Test OK, all checks pass – Reevaluate problem, cause is not electrical
	3	N	N	Y		
	6	Y	Y	N	NO	Test failed; switch defective - replace
N = no continuity, Y = continuity						

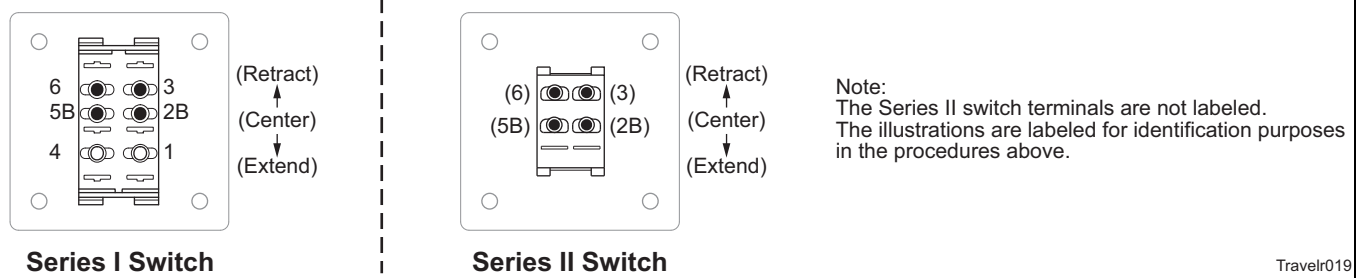

Test 2 is for Series III switches. Use Test 1 for Series I & II switches.

Observe continuity for switch in center position, extend position and retract position.

2a Place one lead of tester on 12V pin (3). Touch 2nd lead to the other pins one at a time.	Pin:	Center	Extend	Retract	YES	Test OK, all checks pass – go to step 2b
	2	N	N	Y		
	4	N	Y	N	NO	Test failed; switch defective - replace
	N = no continuity, Y = continuity					
All other pins should be NO in all switch positions						

2b Place one lead of tester on Ground ₁ pin (1). Touch 2nd lead to the other pins one at a time.	Pin:	Center	Extend	Retract	YES	Test OK, all checks pass – go to step 2c	
	2	Y	Y	N			
	N = no continuity, Y = continuity					NO	Test failed; switch defective - replace
	All other pins should be NO in all switch positions						

2c Place one lead of tester on Ground ₂ pin (5). Touch 2nd lead to the other pins one at a time.	Pin:	Center	Extend	Retract	YES	Test OK, all checks pass – Reevaluate problem, cause is not electrical	
	4	Y	N	Y			
	N = no continuity, Y = continuity					NO	Test failed; switch defective - replace
	All other pins should be NO in all switch positions						

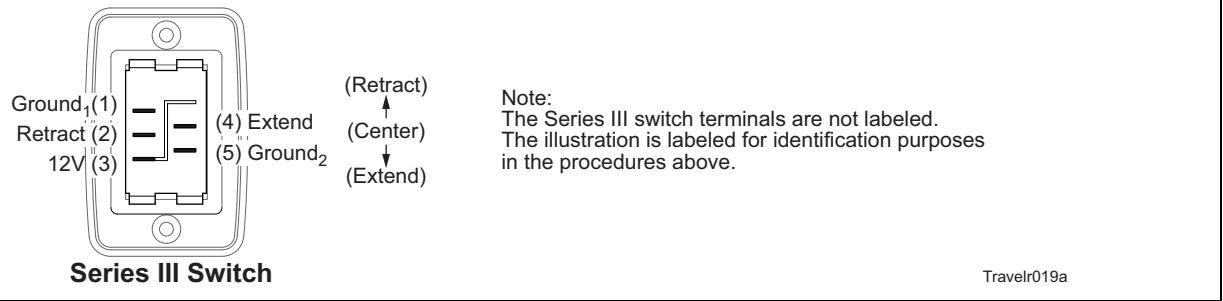

D03 ARM DOES NOT EXTEND OR DOES NOT EXTEND COMPLETELY			
A	Visually confirm motor is working when control switch is pressed.	YES	Go to test B
		NO	Go to test D02 – Awning Does Not Extend and/or Retract – page 14.
B	Confirm that the arm channels, pivot points and contact points are clean and clear of obstructions.	YES	Go to test C
		NO	Clean and Lubricate then retest. If the arm still hangs up – go to test C
C	If the awning has Alumaguard, check that the tractioners are installed and positioned correctly (refer to page 6).	YES	Tractioners OK - Go to test D
		NO	Reposition and attach the tractioners according to the directions on page 6 and retest.
D	1. Open the awning. If the awning arm does not extend, carefully pull the arm out as the fabric is unrolling. 2. Does the fabric sag when the awning is extended? 3. Inspect the shock. Is there evidence of dirt build up and oil leaks on the rod? 4. Hand close and open the arm. Is the tension from the shock mushy, weak or missing? NOTE: To close the awning by hand, push the head of the arm toward the coach. Pulling down on the head or roll bar WILL NOT close the awning.	YES	Shock is defective – replace. See procedure on page 12.
		NO	Shock extends with arm and is solid. Shock pressure is approximately 85 lbs. Go to test E.
E	This step only applies to new Uniguard and Alumaguard installations that do not extend correctly. Check that the centerline of the roll bar is 3/4" ± 1/4" above the centerline of the awning rail. Refer to 052547-001 Eclipse Arms and Canopy After Market Installation Manual or 052547-021 Eclipse Arms and Canopy OEM Installation Manual and reposition the arms as necessary.		

AUTO RETRACT SYSTEMS

The following procedures are intended to aid the service technician to logically resolve operational issues with the auto-retract installation.

NOTES:

1. Refer to the appropriate wiring diagram for the system being tested:
2. In the charts below, YES is a positive response to the test; NO is a negative response.
3. After July 2010, the Direct Response system uses an On/Off switch in place of the "Mode" switch. The auto-retract system is active when the switch is in the ON position and disabled when the switch is OFF.
4. The Extend/Retract switch is also referred to as the Patio switch.
5. Original switches are labeled Series I. New switch configuration is labeled Series III.

D04 THE AWNING OPERATES IN REVERSE OF THE SWITCH PLATE MARKINGS			
<i>For series I switches, the Mode switch must be in the POWER ON or AUTO-RETRACT ON positions for the key FOB to work. For series III switches, the On/Off switch must be ON.</i>			
A	(Series I only) Confirm Switch is mounted in correct position and correctly oriented.. The lens or lens caps should be on the bottom of the switch as indicated by the shaded area.	YES	Switch mounted OK; go to test B
		NO	Carefully remove the switch, rotate 180 and reinstall in panel. Reconnect harnesses and retest
B	Confirm switch is wired correctly. Use the wiring diagram and confirm the wires from the switch to the connector are correctly placed.	YES	Switch wired OK; go to test C
		NO	Rewire the switch according to the wiring diagram
C	Confirm Operation of EXTEND/RETRACT Switch Use test procedure "CT01 Testing a Switch and Harness" on page 19.	YES	Switch and Harness OK; go to test D
		NO	Repair or replace as recommended in procedure and retest
D	Is the control box operating correctly? Use test procedure "CT02 Testing the Control Box" on page 20.	YES	Power and Control Box OK
		NO	Repair as recommended in procedure and retest

D05 THE AWNING DOES NOT EXTEND AND/OR RETRACT USING THE EXTEND/RETRACT SWITCH			
<i>For series I switches, the Mode switch must be in the POWER ON or AUTO-RETRACT ON positions for the key FOB to work. For series III switches, the On/Off switch must be ON.</i>			
A	Confirm Power Supply Is vehicle battery or power source providing 10V to 14V to the control box.	YES	Go to test B
		NO	Correct as required
B	Test Motor Function 1. Disconnect Motor Plug from control box. 2. Attach jumper leads to the emergency terminals located on the back of the motor head. 3. Connect the other ends of the jumpers to a 12-18VDC power source (i.e. drill battery). It may be necessary to try then reverse the leads on the battery and try again. 4. Does the awning move?	YES	Motor is good, go to test C
		NO	Motor is defective - replace
C	Test wire continuity between motor and control box connector.	YES	Wire continuity good – go to test D
		NO	Repair as required
D	(Series I only) Confirm Operation of MODE Switch Use test procedure "CT01 Testing a Switch and Harness" on page 19.	YES	Switch and harness OK; go to test E
		NO	Repair or replace as recommended in procedure and retest
E	Confirm Operation of EXTEND/RETRACT Switch Use test procedure "CT01 Testing a Switch and Harness" on page 19.	YES	Switch and harness OK; go to test F
		NO	Repair or replace as recommended in procedure and retest
F	Is the control box operating correctly? Use procedure "CT02 Testing the Control Box" on page 20.	YES	Control box OK
		NO	Repair as recommended in procedure and retest

D06A AWNING DOES NOT AUTO-RETRACT DURING WINDY CONDITIONS -WINDSMART			
<i>NOTE: The mode switch must be set to Auto-Retract ON.</i>			
A	Confirm that the retract function works using the EXTEND/RETRACT switch	YES	Function works using the switch; go to test B
		NO	Function does not work with switch; go to procedure D01 on page 17
B	Test Anemometer		
	1. Do the anemometer cups spin freely?	YES	Go to step B2
		NO	Anemometer defective - replace
	2. Test signal from anemometer: 2.1. Remove anemometer connector from control box; 2.2. Place an ohmmeter between pins of connector; 2.3. Have a helper SLOWLY turn the anemometer: Does the circuit open and close? It should open and close once for every revolution. When closed, the meter should read approximately 1000ohms	YES	Plug the connector into the control box; Go to "Testing The Control Box"
		NO	The circuit stays open or stays closed or the ohmmeter reads more that 1000ohms (2x or more); go to step B3
	3. Test the wire continuity between the connector and the anemometer.	YES	Continuity OK; replace anemometer
NO		Repair or Replace wires as required	
D06B AWNING DOES NOT AUTO-RETRACT DURING WINDY CONDITIONS –DIRECT RESPONSE			
<i>NOTE: For series I switches, the Mode switch must be in the POWER ON or AUTO-RETRACT ON positions for the key FOB to work. For series III switches, the On/Off switch must be ON.</i>			
A	Confirm that the retract function works using the EXTEND/RETRACT switch	YES	Function works using the switch; go to test B
		NO	Function does not work with switch; go to procedure D01
B	Test Motion Sensor		
	<i>NOTE: A sensor tester is now available from Carefree. Follow the instructions included with the tester. or Follow the steps below.</i>		
	1. Confirm cable is plugged into connector on box marked "Motion Sensor"	YES	Go to step 2
		NO	Correct as required and test.
	2. Remove cable from box and inspect connector on cable. Connector should be wired as shown in the wiring diagram (page 23 or page 24).	YES	Wired OK, go to step 3
		NO	Remove connector and replace
	3. Unplug sensor from control box 3.1. Connect a second sensor into control box. 3.2. Set the control switches for the auto retract function 3.3. Hold the second sensor vertically and gently move up and down.	YES	Awning retracts; original sensor defective - replace
		NO	Awning does not retract; control box defective - replace

D07 AWNING DOES NOT MOVE WHEN KEY FOB BUTTONS ARE PUSHED			
<i>Before continuing, ensure that the system is working correctly at the switch panel. If not, go to DO1" The Awning Does Not Extend and/or Retract Using the Extend/Retract Switch".</i>			
<i>NOTE: For series I switches, the Mode switch must be in the POWER ON or AUTO-RETRACT ON positions for the key FOB to work. For series III switches, the On/Off switch must be ON.</i>			
A	Remove battery from Key FOB and test. Should measure between 2V-3V.	YES	Battery OK - Key FOB does not work – go to test B
		NO	Replace battery
B	Confirm that the Receiver is programmed for the Key FOB (refer to page 28)		If system does not work; go to step C
C	Program a second Key FOB (refer to page 28) and test	YES	2nd Key FOB works. 1st Key FOB is defective.
		NO	2nd Key FOB does not work; go to step D
D	Check the cable between the RR24 and Direct Response control box. As a continuity check, Pin 1 of connector 1 goes to Pin 1 of connector 2; pin 2 goes to pin 2; pin 3 goes to pin 3 and pin 4 goes to pin 4	YES	Cable is OK. Confirm that cable is securely plugged in; go to step 4
		NO	Repair or Replace as required.
D	Replace the RR24 Receiver and test	YES	System works OK. 1st receiver is defective
		NO	System does not work. Reinstall 1st receiver; go to step E
E	Replace Auto-Retract control box		

COMMON TEST PROCEDURES

These common tests are referred to in the diagnostics procedures.

CT01 TESTING A SWITCH AND HARNESS				
<i>Disconnect the switch harness connectors from the control box and remove the plate and switches from the mounting surface.</i>				
A	(Series I) Confirm switch is mounted in correct position and correctly oriented. The lens or lens caps should be on the bottom of the switch as indicated by the shaded area	YES	Switch mounted OK; go to test B	
		NO	Carefully remove the switch, rotate 180° and reinstall in panel. Reconnect harnesses and retest	
B	Confirm switch is wired correctly. Use the wiring diagram and confirm the wires from the switch to the connector are correctly placed.	YES	Switch wired OK; go to test C	
		NO	Rewire the switch according to the wiring diagram	
C	Test the Switch function (this test requires a continuity tester)			
	<ul style="list-style-type: none"> Do not remove the wires from the back of the switch. From the numbered terminal of the switch, trace the wire to the connector; place the tester leads on the connector pins. The pins are not marked on the connector. Steps 1 through 5 are for the Extend/Retract and Wind Speed Switches. Refer to step 6 for the Series I Mode Switch. 			
	1. Using a continuity tester, place one lead on common pin (3 for Extend/Retract, 5 for Windspeed). Place the second lead on pin 1. Put the switch in the center position and measure the continuity. Move the second lead to pin 7, measure the continuity. Circuit should be open	YES	Circuit(s) are open, go to step 2	
		NO	Circuit(s) are closed (continuity exists); switch assy is defective-replace	
	2. Place the second lead on pin 1. Press the switch down ("Extend" for Extend/Retract, "Lo" for sensitivity). Is circuit closed?	YES	Circuit closed; go to step 3	
		NO	Circuit open, switch defective - replace	
	3. Leave the leads in position of step 2. Press the switch up ("Retract" for Extend/Retract, "Hi" for sensitivity). Is the circuit open?	YES	Circuit open: go to step 4	
		NO	Circuit closed, switch defective - replace	
	4. Move the second lead to pin 7. Press the switch down ("Extend" for Extend/Retract, "Lo" for sensitivity). Is the circuit open?	YES	Circuit open: go to step 5	
		NO	Circuit closed, switch defective - replace	
5. Leave the leads in position of step 4. Press the switch up ("Retract" for Extend/Retract, "Hi" for sensitivity). Is the circuit closed?	YES	Circuit closed; go to step 6		
	NO	Circuit open, switch defective - replace		
6. <i>For Series I Mode Switch only</i> - Follow steps 1 through 5 using pins 5, 2 and 8 respectively	YES	Switch tests OK, return to diagnostic		
	NO	Test Failed; switch defective		
7. <i>For Series III On/Off Switch only</i> - Place on lead on each terminal. With switch in OFF is the circuit open? With the switch in ON, is the circuit closed?	YES	Switch tests OK, return to diagnostic		
	NO	Test Failed; switch defective		

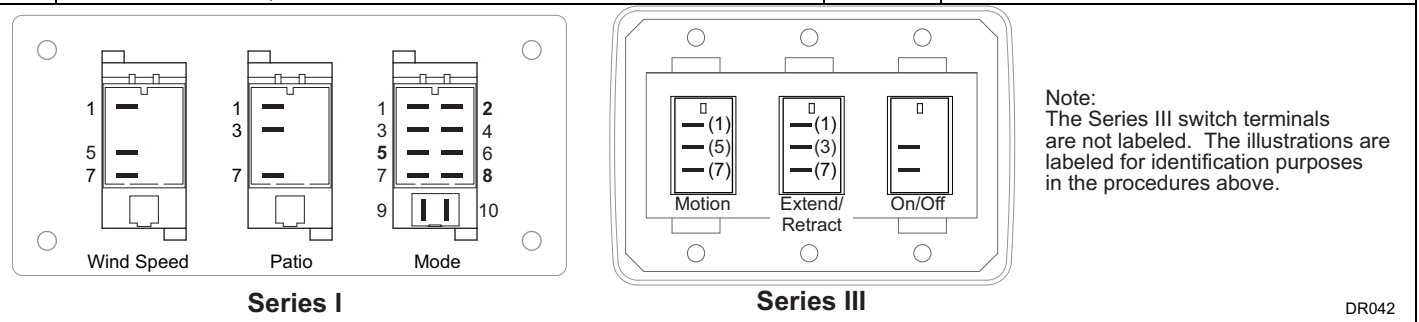

CT02 TESTING THE CONTROL BOX			
<i>This test had been developed as a bench test of the control box.</i>			
A	Test Power		
	1. Check Fuse	YES	Fuse OK; go to step A2
		NO	Replace fuse. If the fuse continues to blow, this may be an indication of a situation with the power lines to the control box or with the control box. If so, replace fuse and go to step A2
	2. Confirm power to the control box: 2.1. Remove the power connector at control box 2.2. Test voltage across terminal. Value should be between 10V and 14V. Polarity must match symbols on control box.	YES	Voltage and Polarity is correct; go to B
		YES	Voltage is correct but polarity is reversed. Reverse wires and retest.
NO		Voltage is less than 10V. Check vehicle power sources and correct as required. If power source OK, check continuity to power plug and repair as required	
B	Test Control Box Function <i>For these tests:</i>		
	<ul style="list-style-type: none"> • Refer to the appropriate wiring diagram • Remove all plugs from the control box except for the power connector. • Place the positive lead of a voltmeter on pin B (motor) and the negative lead of voltmeter on pin A (motor). 		
	1. Measure the "Power On" Setting 1.1. Place a jumper between pins 6 and 8 (this will simulate power ON) 1.2. Place a second jumper between pins 11 and 12 (this will simulate the "Retract Function") 1.3. Does voltage equal -10V to -14V?	YES	Voltage OK; go to step B1.4
		NO	Control box is defective - replace
	1.4. Move the second jumper between pins 12 and 13 (this will simulate the "Extend Function") 1.5. Does voltage equal +10V to +14V?	YES	Voltage OK; go to step B2
		NO	Control box is defective - replace
	2. Measure the "Auto-Retract On" Setting YES Voltage OK; go to step B2.4 2.1. Place a jumper between pins 7 and 8 (this will simulate "Auto-Retract On") 2.2. Place a second jumper between pins 11 and 12 (this will simulate the "Retract Function") 2.3. Does voltage equal -10V to -14V?	YES	Voltage OK; go to step B2.4
		NO	Control box is defective - replace
	2.4. Move the second jumper between pins 12 and 13 (this will simulate the "Extend Function") 2.5. Does voltage equal +10V to +14V?	YES	Voltage OK; reconnect plugs and return to diagnostic
		NO	Control box is defective - replace

CT03 TESTING THE BATTERY AND CHARGER			
<i>This test applies only to battery installations.</i>			
<i>NOTE: for safety and shipping, new batteries are shipped without a charge.</i>			
A	Test Battery		
	1. Using a volt meter, test the battery voltage.	YES	Voltage measures between 14.5 to 17.0 Volts - return to system diagnostic D01
NO		Voltage measures less than 14.5V - Charge battery and retest. If voltage is still less than 14.5 V - go to B	
B	Test Charger		
	1. Observe the red and green LEDs on the charger. Does the Green LED flash (charging) then stay on steady (charge complete)?	YES	If battery still measures below 14.5V, battery pack defective - replace
		NO	Red LED is on - go to step 2
	2. Jiggle the charger connector in the end cap. Does the green led flash?	YES	End cap connector is faulty - replace end cap assembly
NO		Check wires - wires OK, charger defective - replace	

WIRING DIAGRAM - SINGLE SWITCH PRIOR TO JULY 2010

This switch hardware has been discontinued. For wiring replacement switches, use instructions provided with the Single Switch Kit.

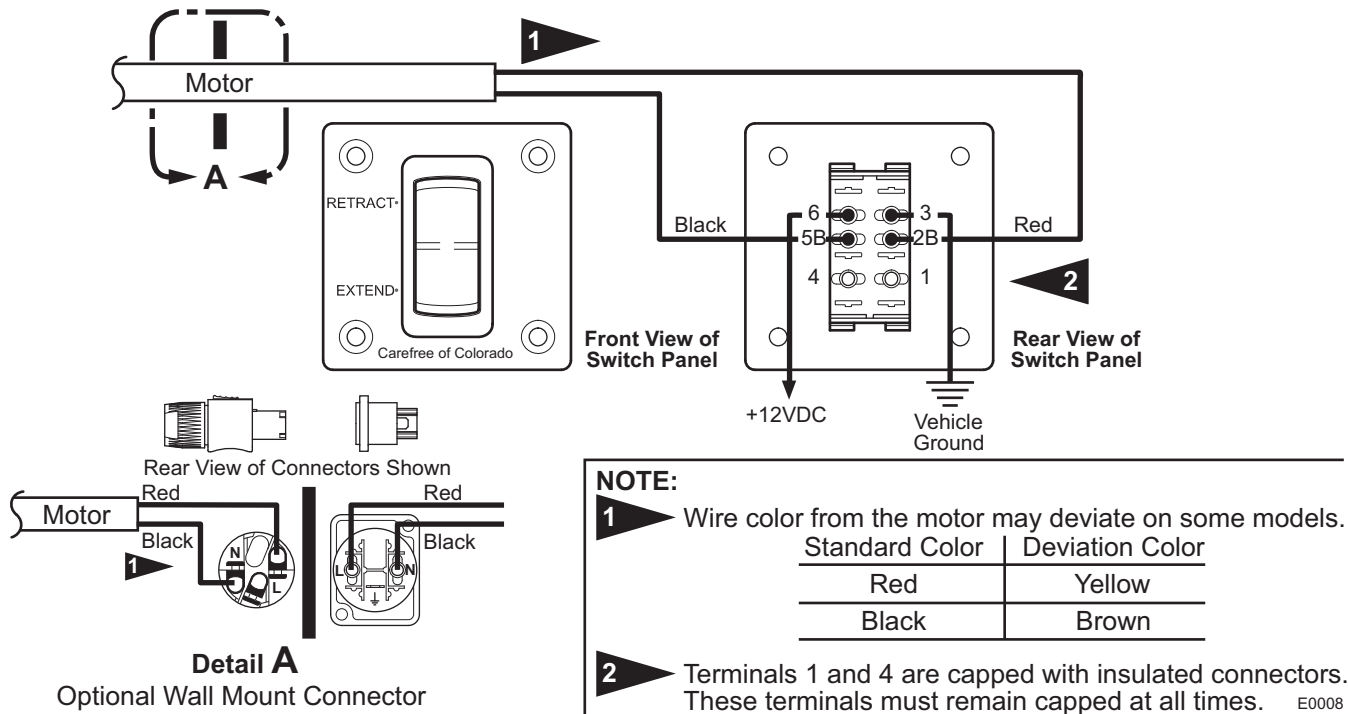

WIRING DIAGRAM - SINGLE SWITCH - JULY 2010 AND ON

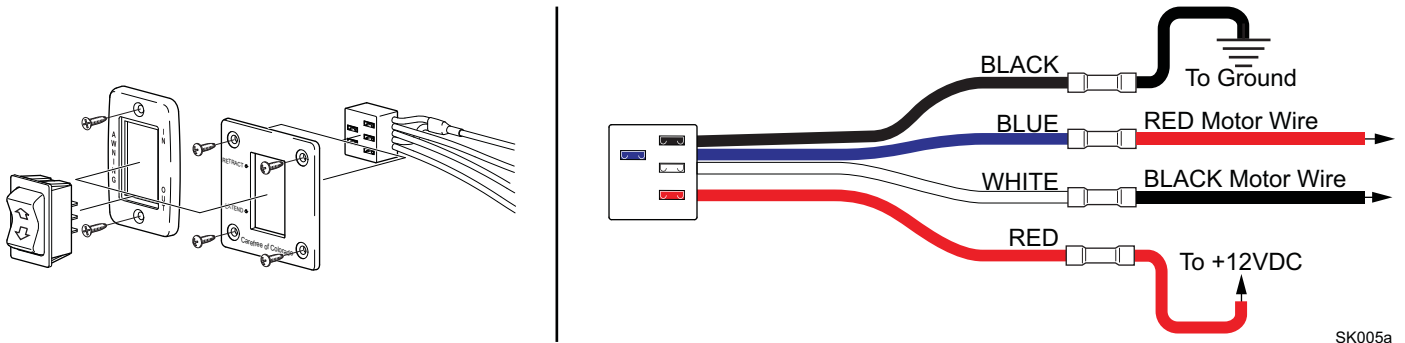

NOTES:

1. If connector block is oriented with wires to the left, reverse the motor wires. WHITE connector block wire goes to RED motor wire, BLUE connector wire goes to BLACK motor wire.
2. For first time replacement installation, refer to installation instructions furnished with replacement switch kit.

WIRING DIAGRAM - MULTIPLE SWITCH PRIOR TO JULY 2010

This switch hardware has been discontinued. For wiring replacement switches, use the schematic below.

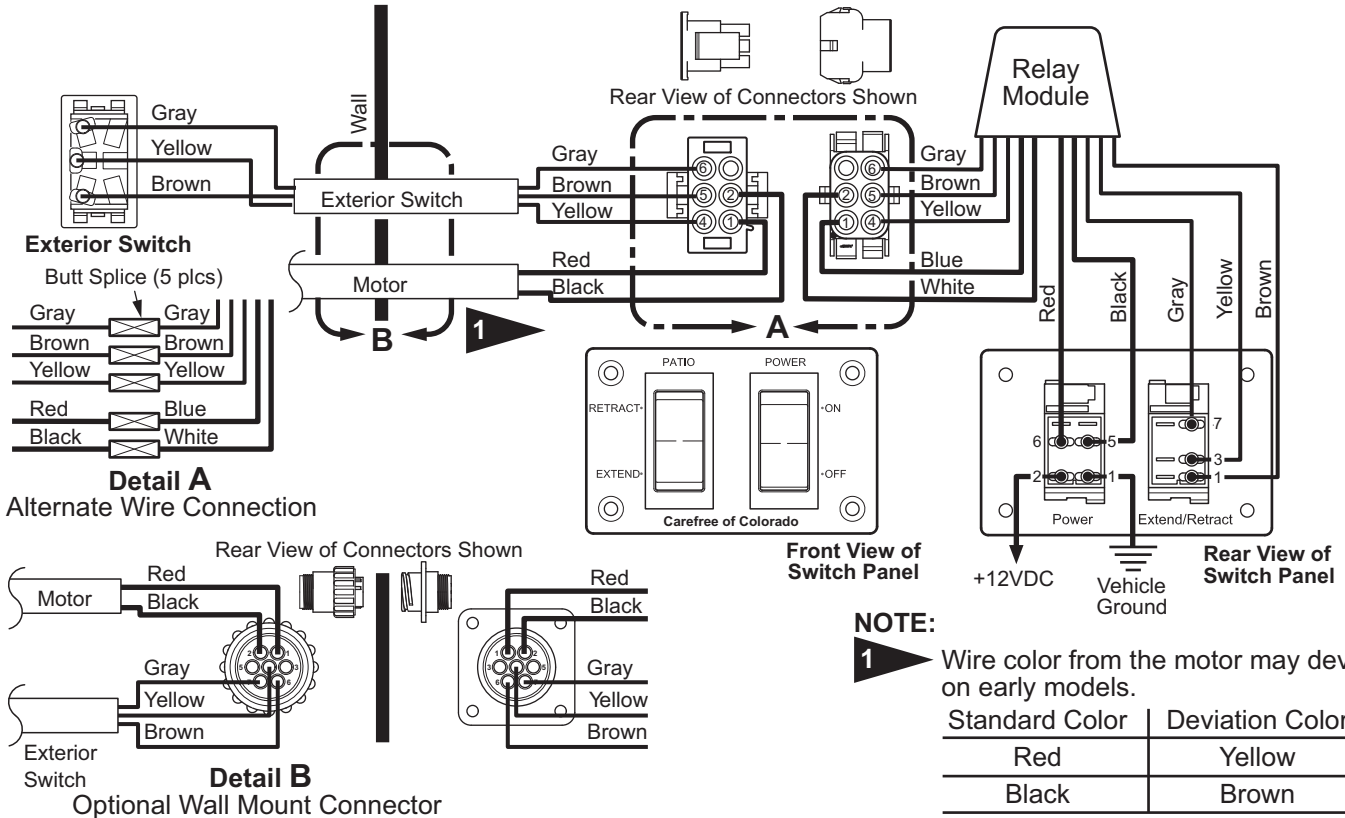

E0032a

WIRING DIAGRAM - MULTIPLE SWITCH AFTER JULY 2010

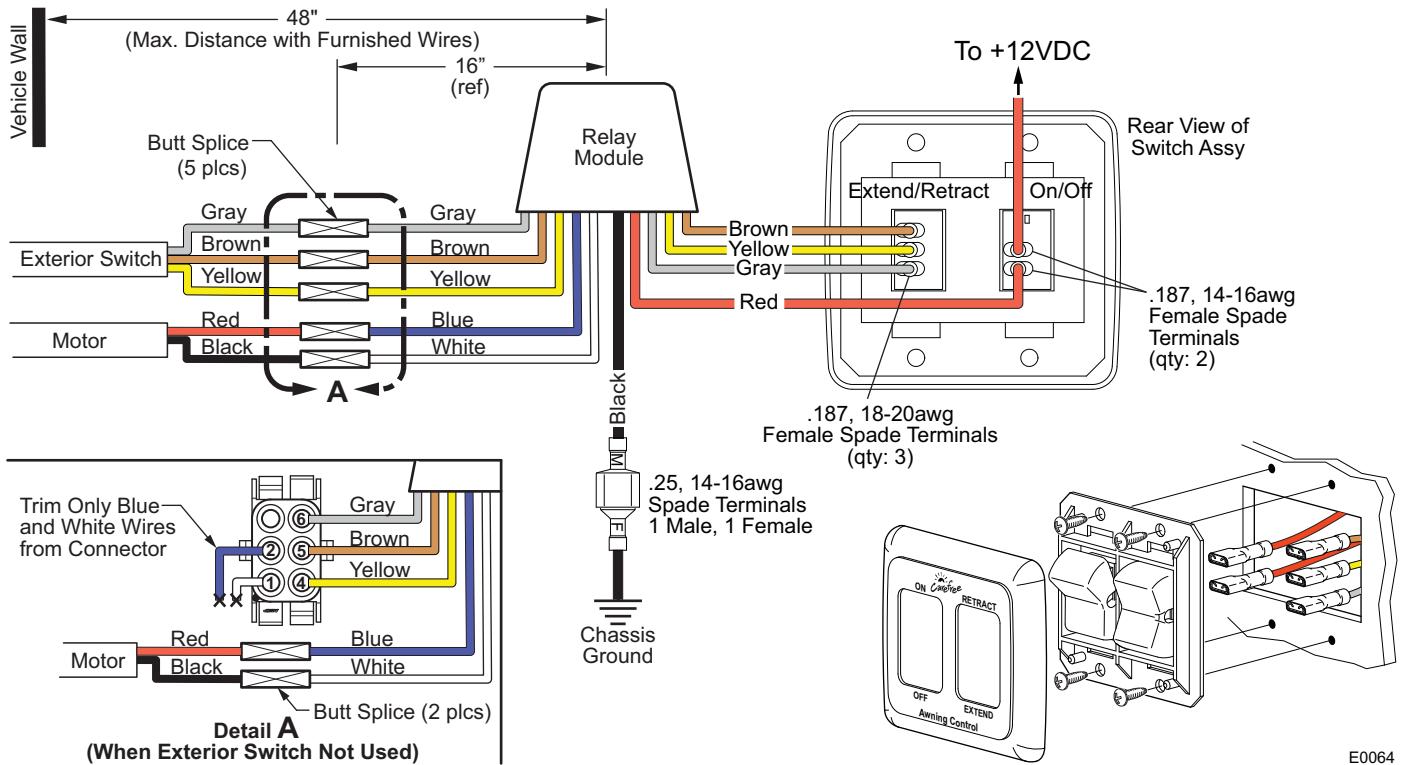

E0064

WIRING DIAGRAM - WINDSMART

The system has been discontinued in 2007 and not available for original or upgrade installations. Parts are no longer available. Superseded by the 12V Direct Response System.

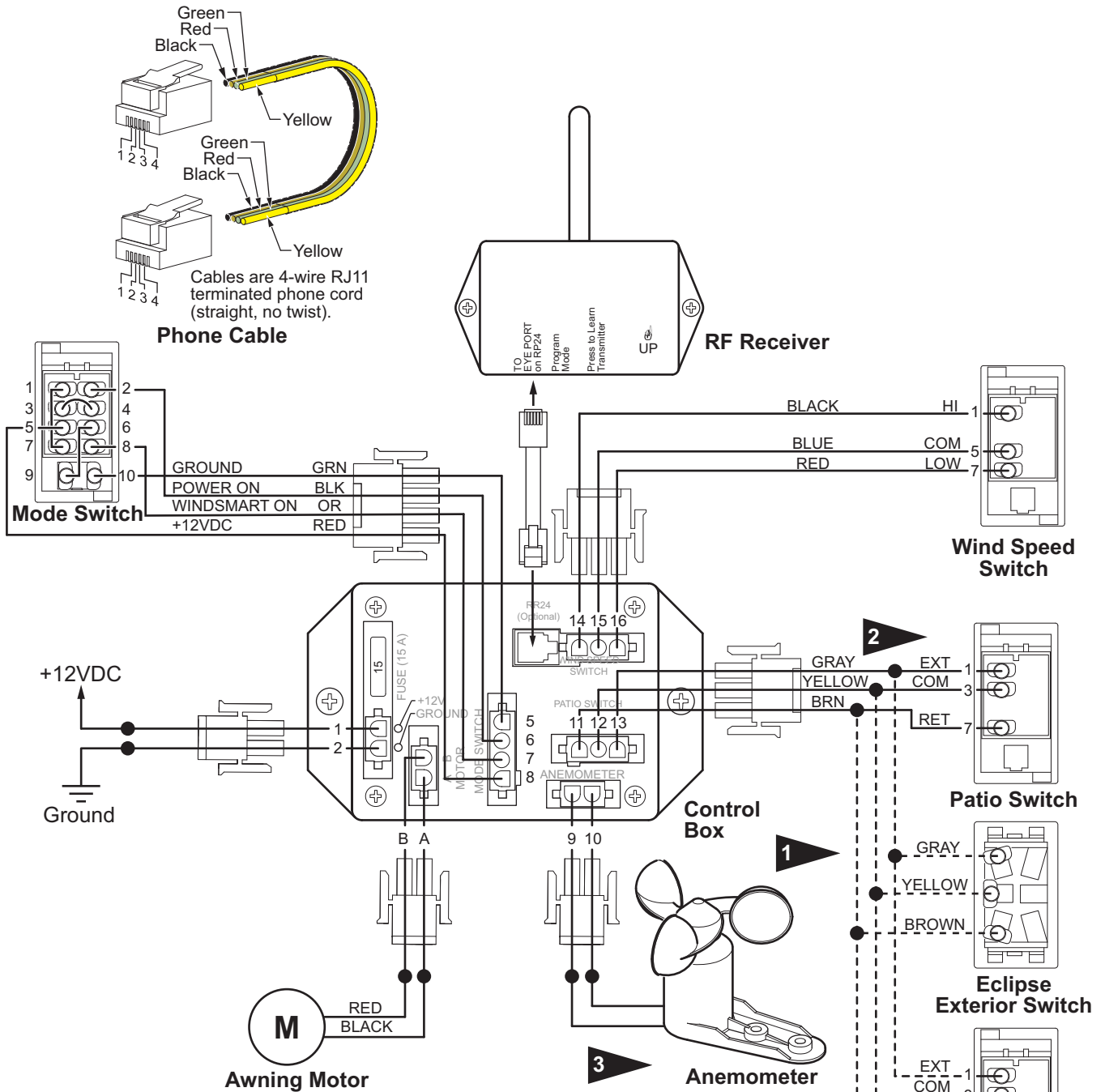

- NOTES:**
- 1** Early versions of the Eclipse Exterior Switch cable may have different wire colors.
- | | Current Color | Previous Color |
|----------------------|----------------|----------------|
| Jacket Color: | Black or White | Gray |
| Wire Colors: | Brown | Black1 |
| | Gray | Black2 |
| | Yellow | Yellow/Green |
- 2** Early versions of the Patio Switch harness may have different wire colors.
- | | Current Color | Previous Color |
|--|---------------|----------------|
| | Brown | Black |
| | Gray | Red |
| | Yellow | Blue |
- 3** Wire colors for anemometer are not pin specific.

WS006a

WIRING DIAGRAM - DIRECT RESPONSE PRIOR TO JULY 2010

This switch hardware shown has been discontinued. For wiring replacement switches, use the schematic on the page 26 (Wiring Diagram - Direct Response after July 2010).

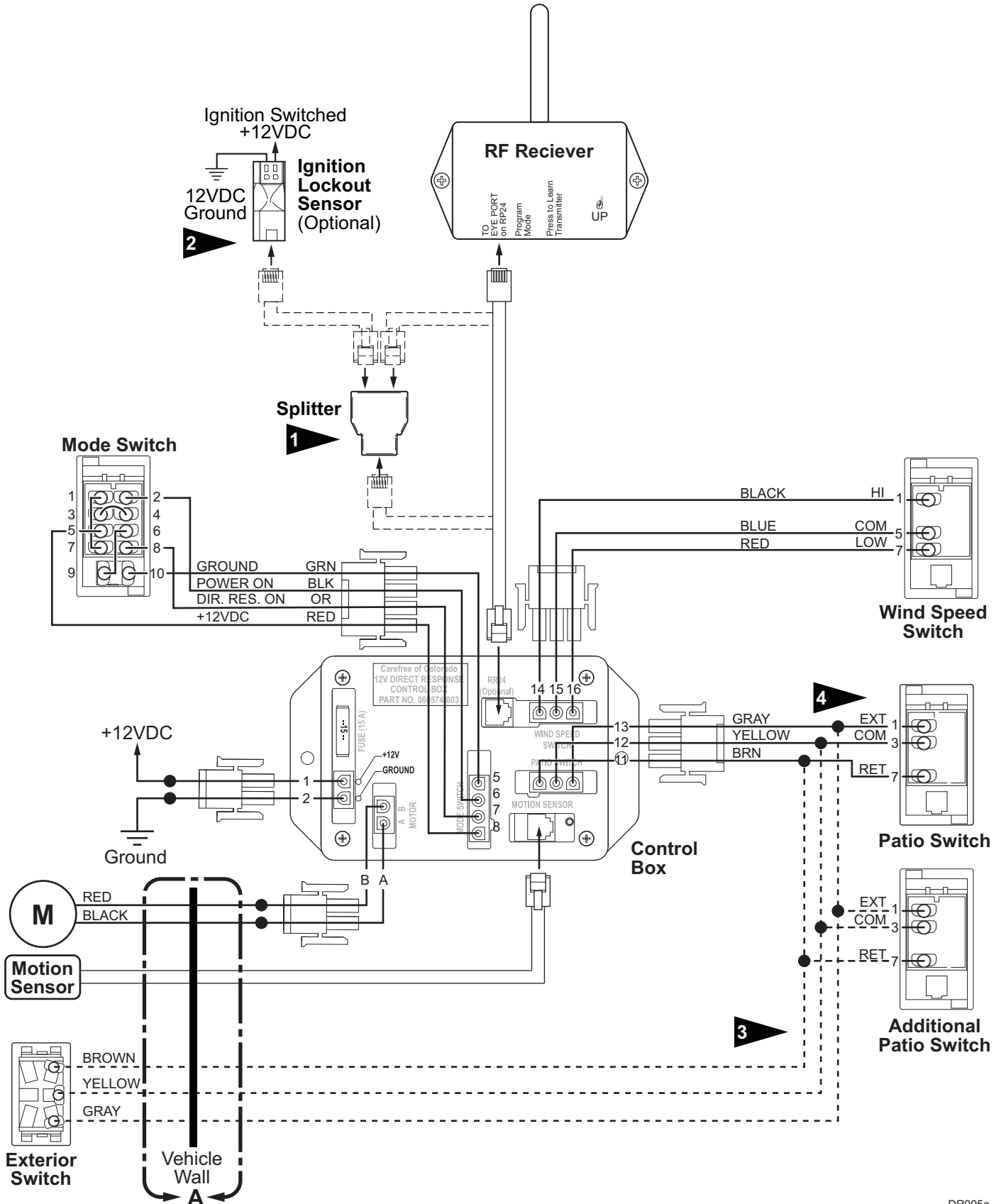

DR005a

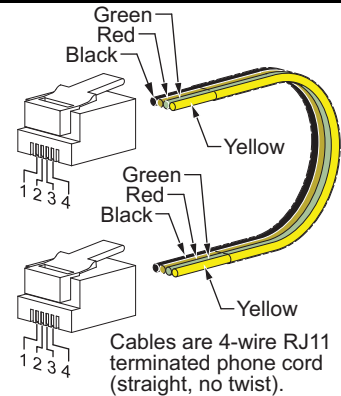
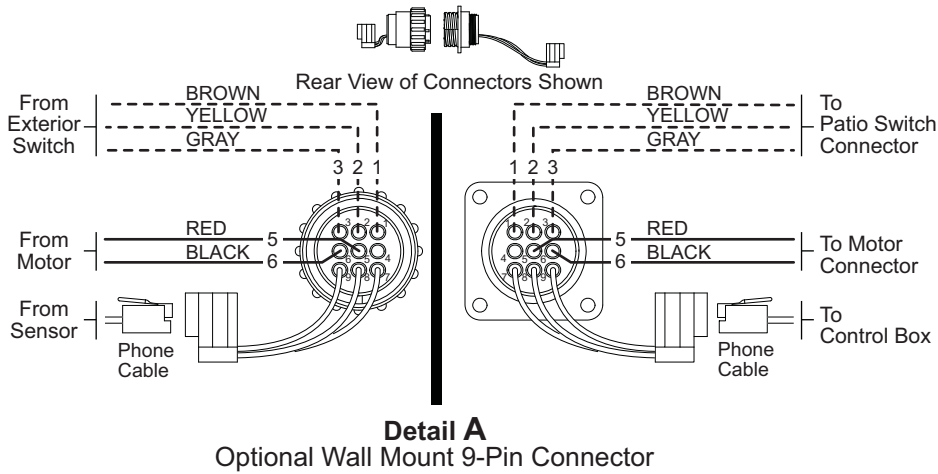

Detail B
Phone Cable

DR005b

NOTES:

- 1 Splitter is used only when the optional Lock-Out Sensor is installed. Connect the RF receiver directly to the control box if Lock-Out is not installed.
- 2 The optional Lock-Out Sensor can only be used with control boxes marked "p/n 060574-003". Wires for the sensor are not pin specific.
- 3 Early versions of the Eclipse Exterior Switch cable may have different wire colors.

	Current Color	Previous Color
Jacket Color:	Black or White	Gray
	Brown	Black1
Wire Colors:	Gray	Black2
	Yellow	Yellow/Green

- 4 Early versions of the Patio Switch harness may have different wire colors.

	Current Color	Previous Color
	Brown	Black
	Gray	Red
	Yellow	Blue

WIRING DIAGRAM - DIRECT RESPONSE AFTER JULY 2010

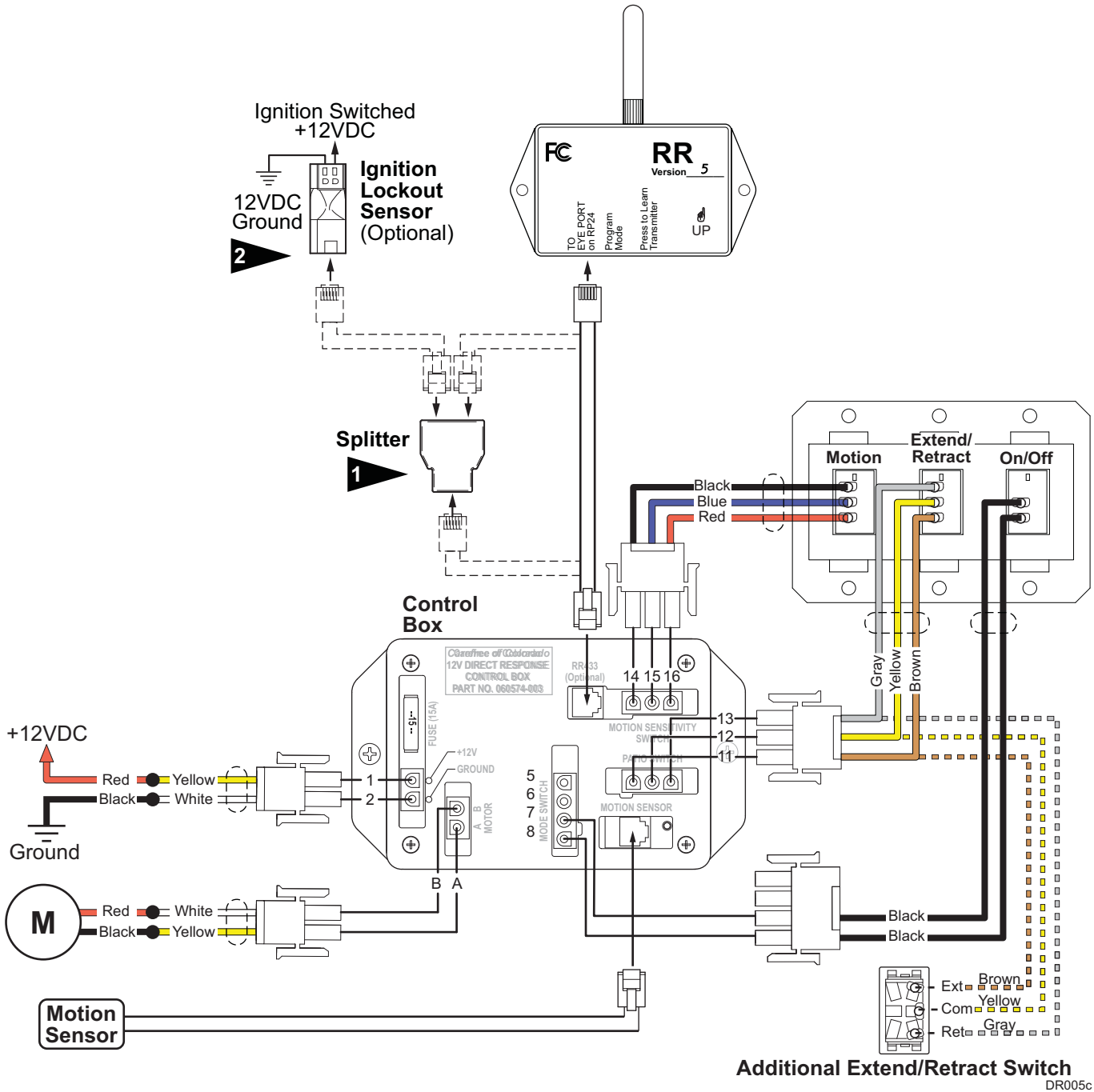

NOTES:

- 1 Splitter is used only when the optional Lock-Out Sensor is installed. Connect the RF receiver directly to the control box if Lock-Out is not installed.
- 2 The optional Lock-Out Sensor can only be used with control boxes marked "060574-003". Wires for the sensor are not pin specific.

WIRING DIAGRAM - DIRECT RESPONSE W/ PRE WIRED HARNESS

OEM Harness (Simplified)

refer to OEM literature for specific harness configuration and details

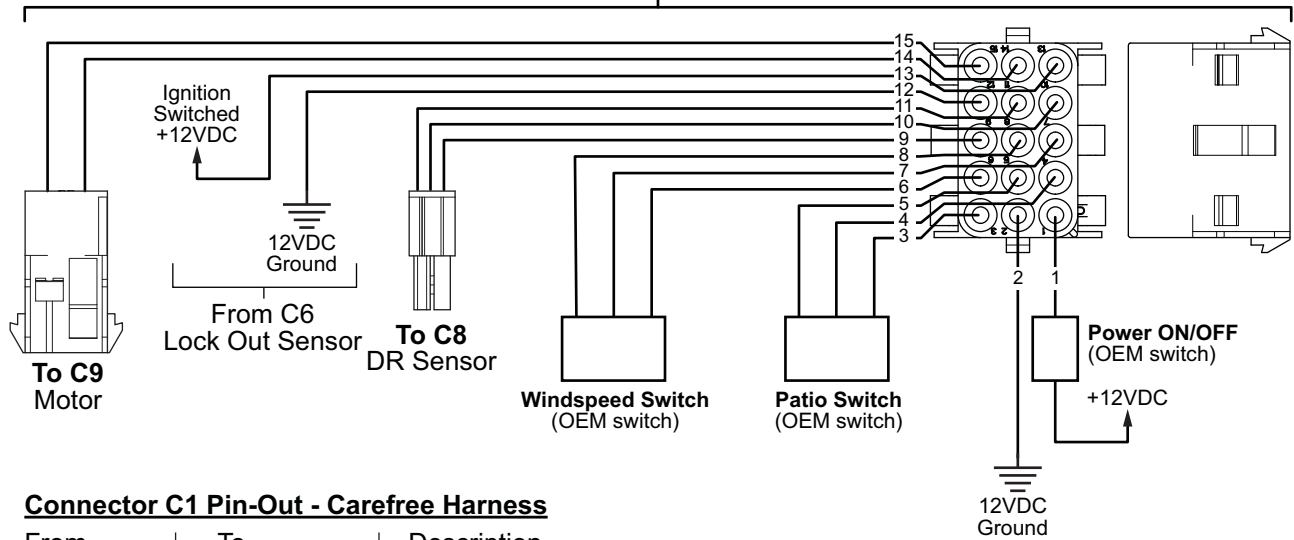

Connector C1 Pin-Out - Carefree Harness

From	To	Description
C1 pin 1	C2 pin 2	+12VDC Power
C1 pin 2	C2 pin 1	12VDC Ground
C1 pin 3	C4 pin 1	Patio Switch, Input for Retract
C1 pin 4	C4 pin 2	Patio Switch, Common (DC Ground)
C1 pin 5	C4 pin 3	Patio Switch, Input for Extend
C1 pin 6	C5 pin 1	Wind Speed, Low
C1 pin 7	C5 pin 2	Wind Speed, Common (DC Ground)
C1 pin 8	C5 pin 3	Wind Speed, High
C1 pin 9	C15 "pin 4"	Motion Sensor, Data Signal
C1 pin 10	C15 "pin 3"	Motion Sensor, +12VDC power
C1 pin 11	C15 "pin 2"	Motion Sensor, Common (DC Ground)
C1 pin 12	C6 pin 1	Ignition Lockout, Signal Input 1
C1 pin 13	C6 pin 2	Ignition Lockout, Signal Input 2
C1 pin 14	C3 pin 2	Motor, A Input
C1 pin 15	C3 pin 1	Motor, B Input

refer to Detail B

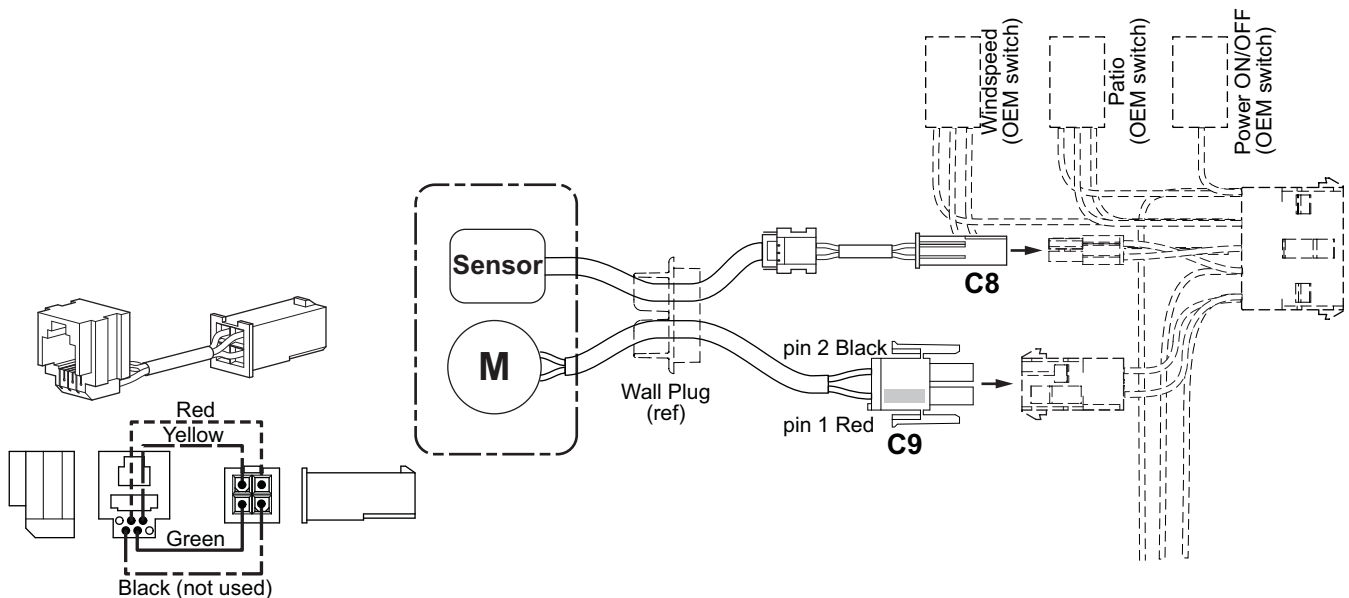

Phone Cable Adaptor
DETAIL A

DR031b

Carefree Harness

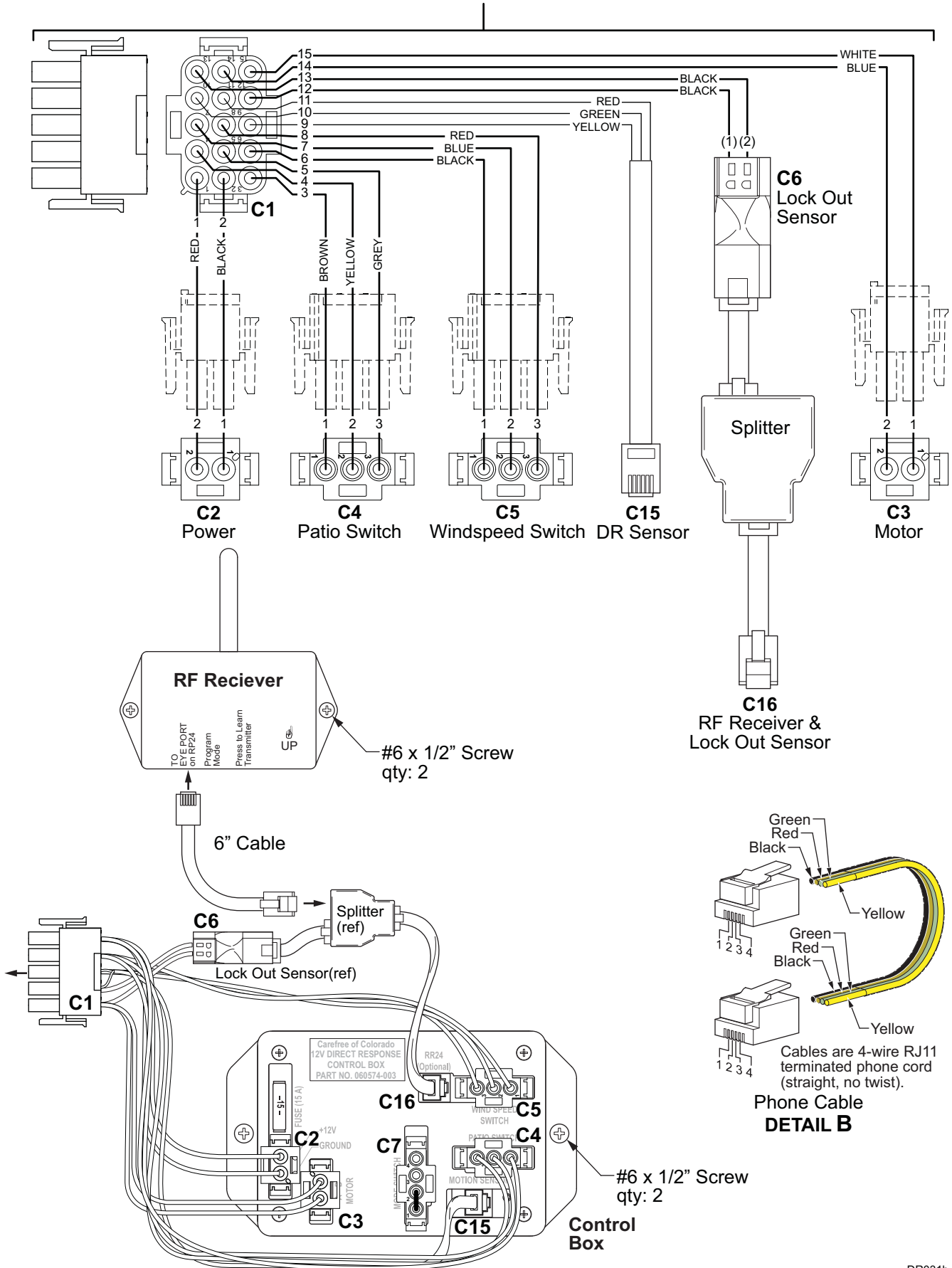

DR031b

LED LIGHTING

SWITCH INSTALLATION

NOTE: Installers may choose to furnish the control switch. The installation requires that the power line (+12VDC) be attached to a dedicated 2A circuit breaker or a 2A in-line fuse must be installed between the switch and power source. For easy access, locate the fuse close to the switch.

1. Determine the location of the switch.
2. At the switch location, cut a 1 1/8" x 1 1/2" hole.
3. Wire the switch as shown below. Wire terminals at the switch are .187, 18-24 awg female disconnects.

NOTE: Allow adequate slack in the 12VDC power line so that the in-line fuse (installed in step 4) can be accessed from behind the switch.

4. Install the in-line fuse:
 - 4.1. Near the switch, cut the red 12VDC power line to the switch. Do not strip the insulation.
 - 4.2. Insert a wire end into one of the wire channels until it butts up against the stop.
 - 4.3. Fold that half of the connector body over until the element contacts the wire. Use pliers to crimp the connector closed.
 - 4.4. Repeat for the second wire end.
 - 4.5. Slide the fuse into the fuse port. Ensure that is firmly seated.
5. Press the in-line fuse, wires and switch into the mounting hole. Secure the switch using two (2) #6 x 1/2" screws.
6. Snap the switch bezel over the switch frame.

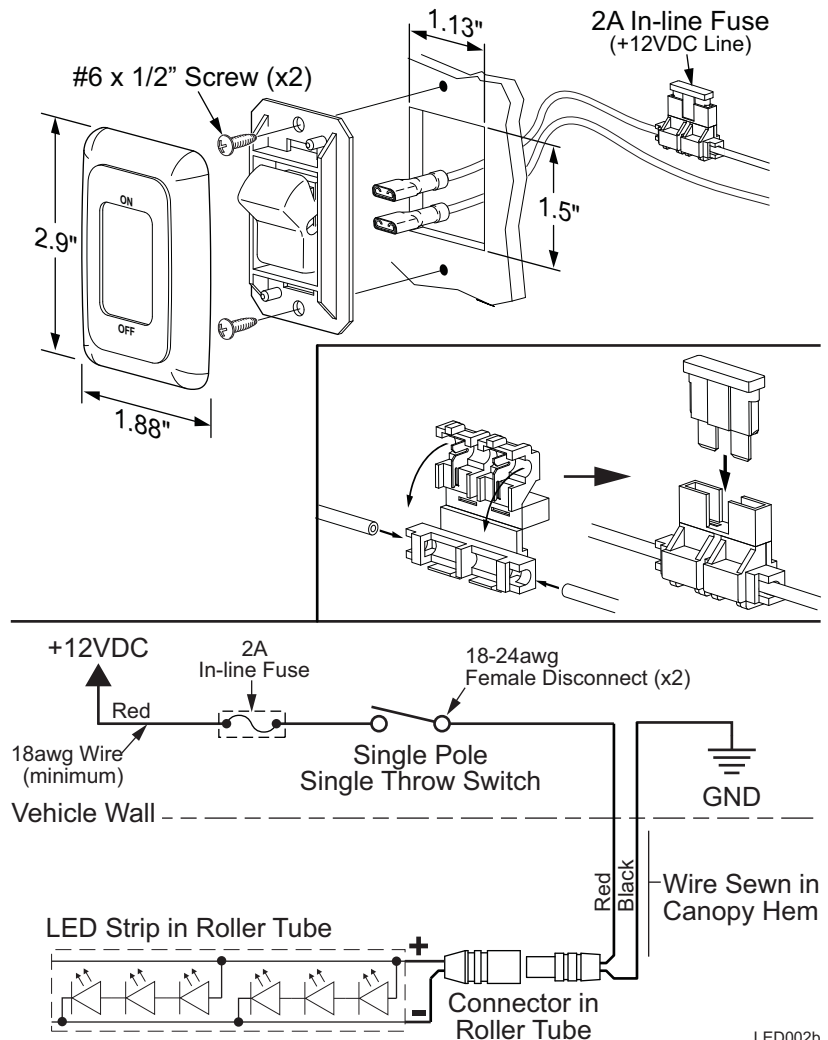

LED002b

REPLACING THE LED STRIP

1. Extend the awning out completely.
2. Disconnect power.
3. Use a non-permanent marker to mark the location of the ends of the LED strip.
4. Clamp the canopy harness in the canopy to prevent the wire from pulling up into the seam of the canopy. This can be done with a paper clip or similar device that will not damage the wires or canopy.
5. Remove the slot covers from the ends of the LED strip and set aside.
6. Carefully pull the wires and connectors out of the roller tube through the hole that is located behind the slot cover location. Disconnect the connectors.
7. Remove the existing LED strip.
8. Clean the slot to remove any dirt and tape residue.
9. Starting at the reference mark made previously, remove the release paper from the back of the new strip and press the strip into the LED slot.
10. At the end of the roller tube, cut the LED strip to match the mark made previously. To trim the LED strip, always cut between the 4-pad cluster as shown.
11. Connect the canopy harness connector and LED connector. Then carefully push the connectors into the roller tube.
12. Press the slot covers into the LED slot.
13. Restore power and test.

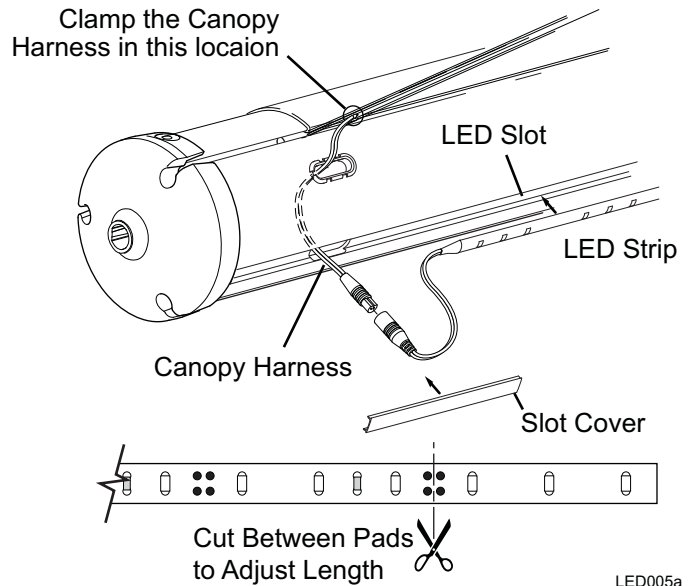

CANOPY HARNESS REPLACEMENT

NOTE: Acrylic canopies uses a soft rivet in the hem next to the awning rail to hold the harness in place. Dual tapered canopies do not use the rivet. If replacing a harness in a tapered canopy, skip steps 6 and 11.1.

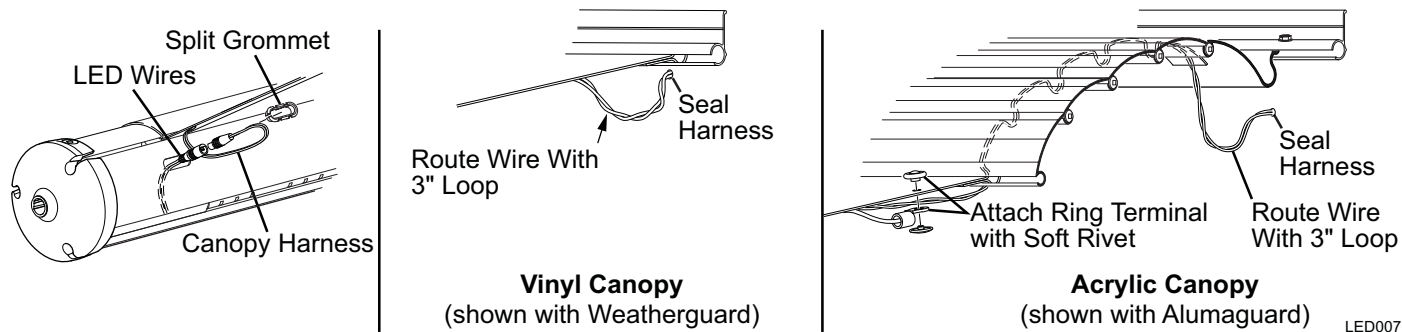

1. Extend the awning out completely.
 2. Locate and remove the split grommet from the roller tube.
 3. Carefully pull the wires and connectors out of the roller tube. Disconnect the connectors.
 4. Clamp the LED harness connector outside the roller tube to prevent it from falling back into the roller tube. This can be done with a paper clip or similar device that will not damage the wires.
 5. At the awning rail, clip the harness close to the canopy. Clamp the harness going into the vehicle to prevent it from falling in the vehicle wall.
 6. For acrylic canopies only: Remove the rivet from the canopy. This is a soft rivet and can be cut off with side cutters.
 7. At the roller tube, cutoff the connector from the old canopy harness.
 8. Securely tape the new harness to the old harness.
 9. Carefully use the old harness to pull the new harness through the hem of the canopy.
 10. After the new harness has been routed in the canopy hem:
 - 10.1. Connect the canopy harness connector and LED connector. Then carefully push the connectors into the roller tube.
 - 10.2. Place the split grommet over the canopy harness and press the grommet into the hole of the roller tube.
 11. At the vehicle wall:
 - 11.1. For acrylic canopies only: Attach the new harness terminal ring to the canopy using a new rivet.
 - 11.2. If the canopy has a metal wrap, attach the wire to the inside of the wrap (see page **Error! Bookmark not defined.**) then proceed with the next step.
 - 11.3. At the vehicle wall, route the new canopy harness through the wall to the switch.

Tip: Tie the new harness to the old harness that was cut previously. Use the old harness to pull the new harness through the wall to the desired location.
 - 11.4. At the vehicle wall, provide a 3" loop of harness between the canopy and wall. Seal the wall entrance hole and harness with a quality silicone sealant.
 - 11.5. Connect the new harness to the switch. Two (2) .187, 18-24 awg female disconnects are provided if connecting to a switch.
 - 11.6. Alternate method: At the wall, splice the new harness to the existing harness using 24 awg butt connectors. Push the connectors into the vehicle wall. Seal the wall entrance hole and wires with a quality silicone sealant.
- NOTE:** Be sure to allow enough harness from the canopy to provide a 3" loop of harness and adequate length for the connectors to be pushed inside the wall before sealing the hole and harness with a quality silicone sealant.

ATTACHING THE HARNESS TO FABRIC WRAP

When replacing the canopy only or replacing the canopy harness, it is necessary to attach the cable to the inside of the wrap.

For vinyl canopies with Weatherguard, the harness is routed in the seam of the Weatherguard, no additional attachment is necessary.

For other wraps follow the directions below:

1. Open the awning to access the inside surface of the wrap.
2. Clean the inside surface of the wrap.

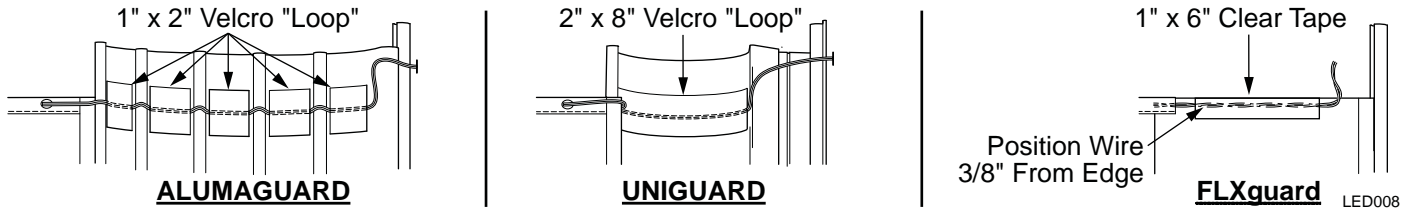

3. Attach the harness to the inside surface.
 - 3.1. For Alumaguard: Use 1" by 2" pieces of Velcro (loop) taping the harness on each slat between the joints.
 - 3.2. For Uniguard: Tape the harness to the inside surface using a 2" x 8" piece of Velcro (loop).
 - 3.3. For FLXguard: Position the harness approximately 3/8" from the edge of the material. Attach using a 1" x 6" piece of clear tape (the tape is a special bond tape available from Carefree).

STANDARD SERVICE PROCEDURES

PROGRAMMING THE REMOTE RECEIVER

Early transmitters & receivers operate on a frequency of 418MHz. Models for 2007 & on operate on 433MHz. The transmitter and receiver frequencies must match. Identifying the transmitter frequency is described under the operational notes below.

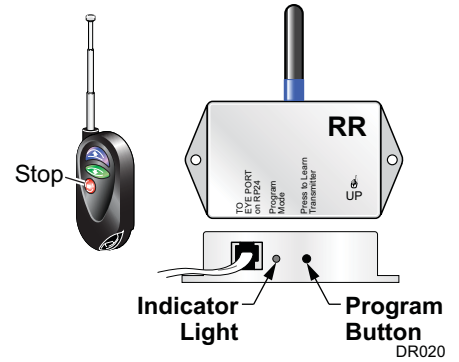

1. Power to the control box must be on.
2. Press and release the “Press to Learn Transmitter” button on the bottom of the receiver box. The receiver is in program mode when the red light comes on.
3. For Gray Button Key FOBS: Press and release ANY button on the remote. It is recommended to use the STOP button. The red light will go out after the receiver learns the remote signal.

⚠CAUTION When the receiver learns the transmitter signal, the system will perform the operation of the button pressed. Example: pressing an "extend" button during the learning phase will cause the awning to extend when the receiver learns the signal. Use caution to avoid unexpected movement by the awning.

4. For Key FOBS w/ Antenna: Press and release the STOP button on the remote. The red light will go out after the receiver learns the remote signal.

NOTE: Pressing the stop button will cause the blue up arrow button to default as the close (retract) function. If a function button is pressed to train the receiver, it will be programmed as the close (retract) button. Example: Pressing the bottom button will program the bottom button for retract and the top button as extend.

5. Repeat for each additional remote.

Operational Notes:

1. Transmitter and receiver must match in frequency (418 MHz or 433 MHz).

1.1. Key FOBS:

1.1.1. The gray button key FOBS are marked with a label for 418 MHz or 433 MHz.

1.1.2. Key FOBS w/ antenna are 433 MHz

1.2. Receivers

1.2.1. 418 MHz receivers are marked "RR24".

1.2.2. 433 MHz receivers marked "RR" Version 1 can only be used with the 433 MHz gray button Key FOB.

1.2.3. 433 MHz receivers marked "RR" Version 5 is compatible with any 433 MHz Key FOBS marked version 2 thru 5.

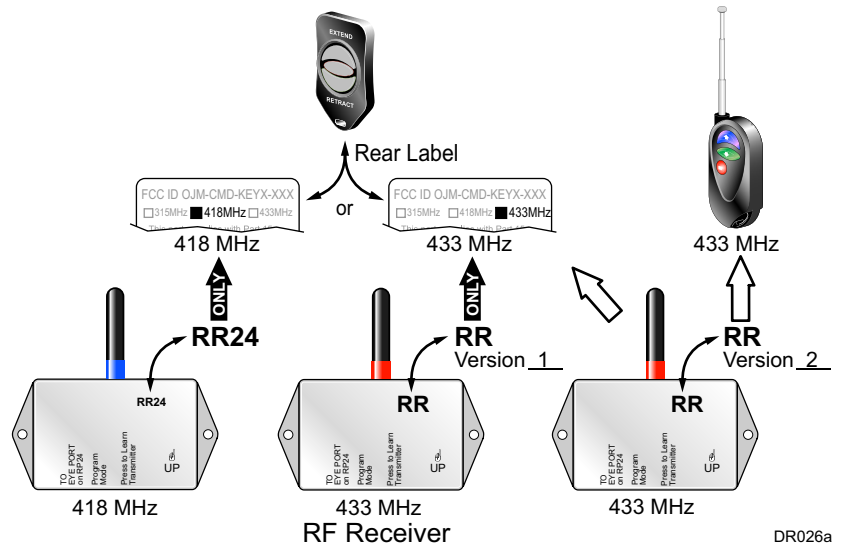

2. The receiver exits the program mode after ten seconds.
3. If the light does not come on above, the memory is full and must be cleared.
4. To clear the memory: press and hold the transmitter learn button for 5 seconds. While holding the button, the indicator light should be off for the full 5 seconds then come on.
5. The system may be programmed for up to 5 remotes. Additional remotes may be ordered separately.

BATTERY REPLACEMENT

This procedure only applies to the Universal Eclipse with battery. The Eclipse battery configuration uses one exterior switch and one rechargeable 14.4V NiCd battery pack mounted in the right arm assembly.

This system has been discontinued. Limited parts availability.

NOTE: For safety and shipping, new batteries are shipped without a charge. It will be necessary to charge the battery before using. Refer to "Charging the Battery" below.

1. Remove the two socket head cap screws holding the bottom cover and set aside. Allow the bottom cover to hang down on the wires.
2. Remove the fascia.
3. Disconnect the battery connector from the switch in the bottom cover.
4. Pull out the battery and connector. The mounting brackets are spring clips, use care to not bend or distort the brackets.
5. Thread the connector and wires down along the inside of the channel, behind the springs and pins.

NOTE: Orient the battery with the wires starting at the top of the battery pack.

6. Spread the wires apart and route to each side of the lower bracket.
7. Place the top of the battery into the top bracket.
8. Snap the bottom of the battery into the bottom bracket.
9. Connect the battery and motor connectors to the end cover with switch.
10. Reinstall the bottom cover and fascia.

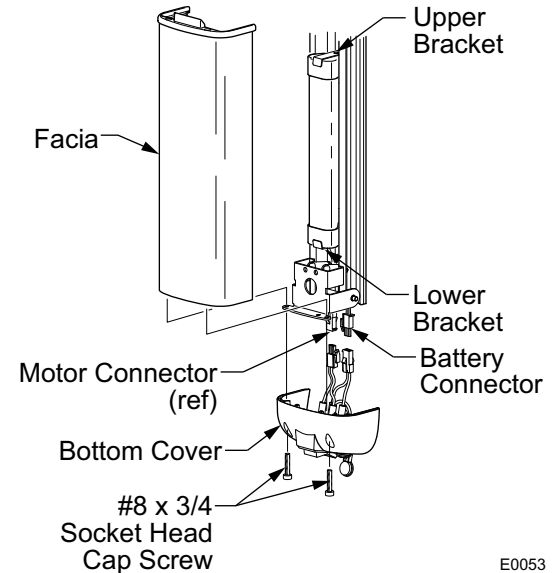

E0053

Charging the Battery

NOTES ABOUT THE BATTERY:

- Always discharge the battery completely by operating the awning before recharging. DO NOT charge the battery after every use.
- Always charge the battery fully. Do not partially charge the battery.
- Do not operate the awning while the battery is charging. If it is necessary to operate the awning before the battery is fully charged, first disconnect the charger to prevent possible damage.
- If the awning is operated while the charger is plugged in, the charger will falsely report a full battery charge. It will be necessary to reset the charger by unplugging the power cord, wait 10 seconds then reconnect.
- Do not leave the charger plugged into the battery without power cord plugged in. This can cause the battery to discharge through the charger. Damage to the battery can occur over extended periods.

1. Connect the charger to the vehicle's 12 volt auxiliary outlet (cigarette lighter).
2. Connect the charger to the battery through the battery receptacle. The receptacle is located next to the switch on the bottom of the right arm.
3. Observe the LEDs located on the side of the charger. When the green LED stays steady on, the battery is fully charged. Disconnect the charger.

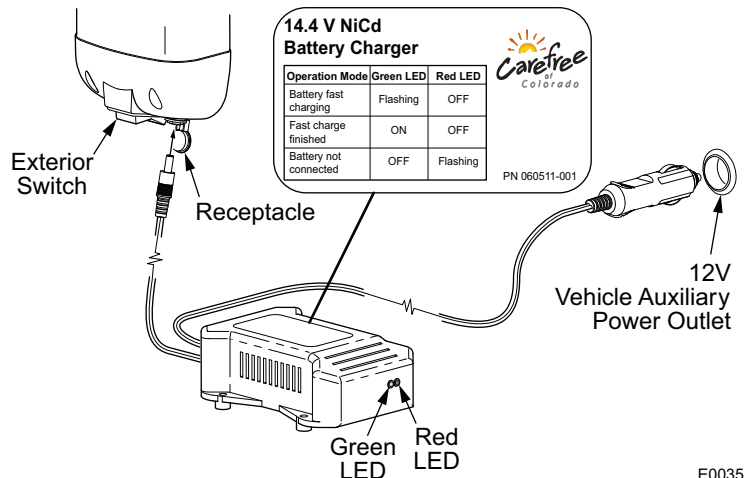

E0035

STANDARD MAINTENANCE

Maintaining a Carefree Awning is easy. Just follow these basic steps:

- Always operate the awning according to the instructions.
- Periodically check that the fasteners are tight. Tighten if necessary.
- Keep the awning fabric and arms clean.

FABRIC CARE

⚠CAUTION Do not use oil based cleaners or any caustic, granulated, or abrasive type cleaners on your Carefree product.

1. One of the best ways to keep the fabric looking good and to delay the need for deep or vigorous cleanings is to hose fabrics off on a monthly basis with clear water. This practice will help prevent dirt from becoming deeply imbedded in the fabric. In most environments, a thorough cleaning will be needed every two to three years.
2. When it's time for a thorough cleaning, the fabric can be cleaned while still on the awning frame.
 - For Vinyl Fabric – Use a soft brush and warm water with soap.
 - For Acrylic Fabric – Use a stiff brush and warm water with soap.
3. When cleaning the fabric, it is important to observe the following:
 - Always use a natural soap, never detergent.
 - Water should be cold to lukewarm, never more than 100°F.
 - Air-dry only. Never apply heat to the fabric.
 - Always allow the fabric to dry thoroughly before rolling up the awning.

Mildew

Mildew is a fungus growth that looks like dirt. Vinyl coated polyester fabrics are mildew resistant because of a chemical biocide in the vinyl coating. Under ordinary conditions, mildew will not appear. However, in areas where high temperature and humidity are common, mildew can be a problem and required the material to be washed more frequently. Thoroughly rinse the fabric with clean water and allow to air dry completely before rolling up the awning.

Pooling

When water collects on the top of the fabric, this is known as "pooling". This can occur during inclement weather or if a running air conditioner discharges over the awning. The water is dumped when the awning is retracted. It is recommended that if water accumulates on the top; retract the awning in steps (8"-12") to dump the water. This will help prevent the fabric from stretching or distorting.

The effects of wind and rain on an awning are unpredictable. Severe damage to the awning and the vehicle may result. IF WIND OR EXTENDED PERIODS OF RAIN ARE EXPECTED, ROLL UP THE AWNING AND SECURE FOR TRAVEL.

ARM CARE

The best method of keeping the arms and braces operating smoothly is to clean them. Dirt and debris can cause the channels not to slide easily.

Periodically wash out the channels with running water (i.e. a hose) to keep them clean. If the channels still do not slide easily, lightly spray the joints and/or inside of the channels with a dry silicone lubricant, after the arms have been cleaned and dried thoroughly.

Hardware Maintenance

- Replace any parts that become damaged.
- Periodically check all mounting hardware, screws, lags, etc., and re-tighten when necessary.

MOTOR MAINTENANCE

- Check all wiring and connections for wear. Repair when needed.

EMERGENCY OPERATION

If the original power source fails or is unavailable, the Eclipse has emergency override terminals (12V). The terminals can be used with a 9V-18V power source, such as a cordless drill battery or car battery.

⚠ WARNING Do NOT CONNECT THE TERMINALS TO A 110V POWER SOURCE! DOING SO WILL PERMANENTLY DAMAGE THE AWNING!

⚠ CAUTION Do not use the emergency terminals without following the directions below. The electronic circuit creates a dynamic brake for the motor by shorting and grounding the motor leads. Steps 1 & 2 remove the brake to allow the emergency override to work.

1. If there is an external plug, disconnect the plug, then go to step 3.
2. Awnings without an external plug:
 - 2.1 Remove the front cover from the motor head. There are six (6) small screws, do not remove the larger screw toward the center.
 - 2.2 Disconnect the input cable wires from the terminals. Do NOT disconnect the wires to the motor.
 - 2.3 Leave the wires disconnected and reattach the front cover.
3. Attach the provided jumper leads to the terminals, located on the rear of the motorized head.
4. Connect the other ends of the jumper leads to a 12V source. If the awning does not begin to move, reverse the leads.
5. Maintain contact throughout the retraction process.

⚠ CAUTION Use care when retracting the awning as the it may move abruptly.

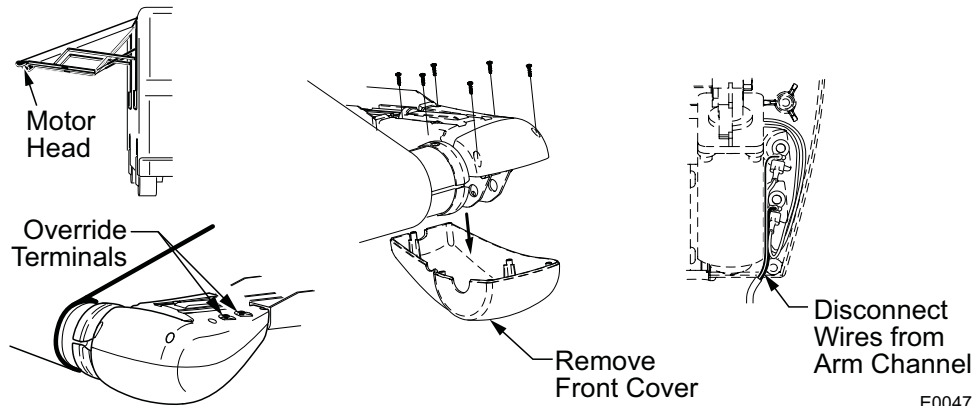

E0047

PART NUMBER LISTING

PART NUMBER/SERIAL NUMBER LOCATION

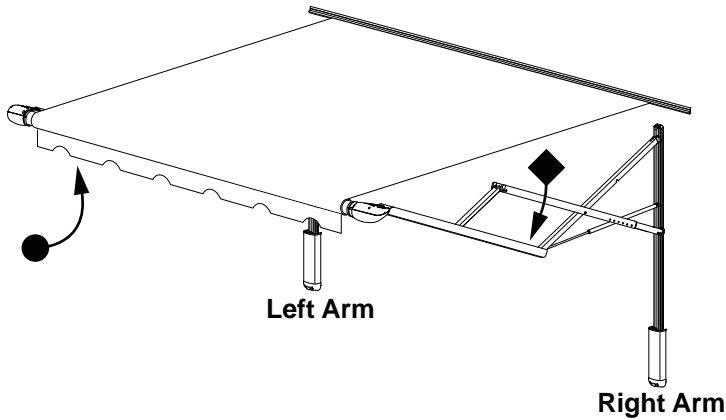

- ◆ Arm part and serial numbers are located on the inside of the lower arm channel.
- Roll bar part and serial numbers are located on the roller tube and valance care label.

E0048

ARMS PART NUMBER CONFIGURATION

Example: Part Number: V X J E 5 0 H W

STYLE CODE	COLOR	ARM TYPE	ARM CONFIGURATION/CONTROLS
VX	JE	50	HW
Eclipse	Black	Universal	AM, Interior and Exterior Switches
VX = All Eclipse	Refer to sales order information for specific codes and colors available	50 = Universal 51 = Short 52 = XL	BT = AM, Battery Powered Discontinued HW = AM, Interior and Exterior Switches RF = AM, Exterior Wall Plug and Single Interior Switch. Used for One-Touch Upgrade. CS = OEM, Interior and Exterior Switches DR = OEM, Direct Response EP = OEM, Exterior Wall Plug and Single Interior Switch SP = OEM, Exterior Wall Plug with Interior and Exterior Switches AM - Aftermarket or Retrofit uses extended mounting channel & top mounting bracket OEM - Original Equipment Manufacturer

ROLLER PART NUMBER CONFIGURATION

Example: Part Number: Q J 1 8 7 9 7 9

STYLE CODE	SIZE	CANOPY COLOR	FABRIC WRAP TYPE/COLOR
QJ	18	79	79
Vinyl Roller Assy	18' LG	Ocean Blue Vinyl	Ocean Blue/Cream Weatherguard
QJ = Vinyl or Polyweave	12'	VINYL	VINYL (Weatherguard)
QL = Acrylic w/ Alumaguard	13'	CUSTOM GRAPHICS	ALUMAGUARD / UNIGUARD
QK = Vinyl or Polyweave w/ Alumaguard	14'	POLYWEAVE	CUSTOM
WA = 9' XL vinyl or Polyweave	15'	ACRYLIC	ALUMAGUARD / UNIGUARD
WB = 9' XL Vinyl or Polyweave w/ Alumaguard	16'	Available In Horizontal Or Vertical Stripe Or Solid	
WC = 9' XL Acrylic w/ Alumaguard	17'	CUSTOM ACRYLIC	
OU = Acrylic w/ Uniguard	18'	Custom Colors Are Available	
OT = Polyweave w/ Uniguard	19'		
	20'		
	21'		
Refer to sales order information for specific codes and colors available			

ILLUSTRATED PARTS LIST

Arms

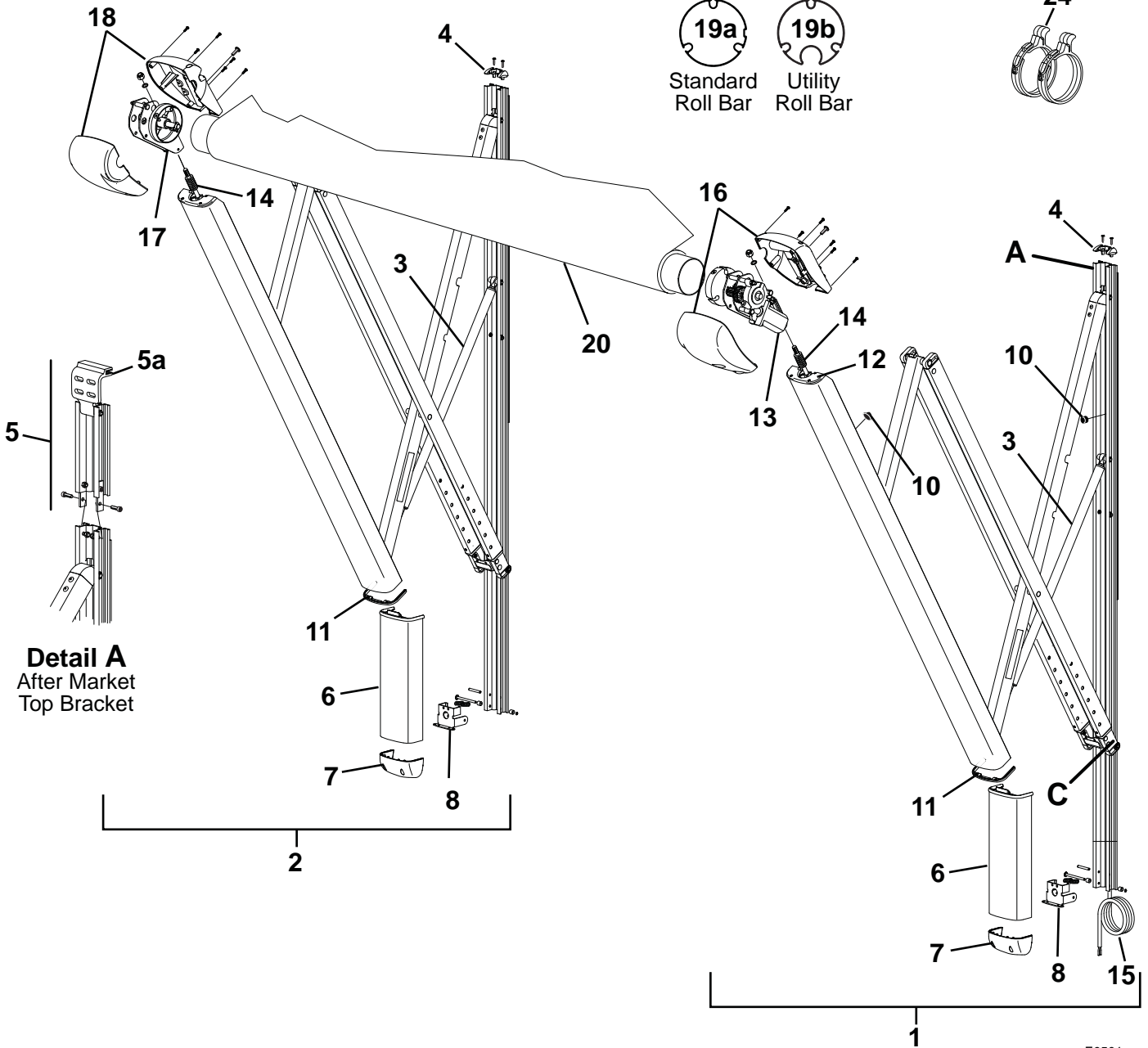
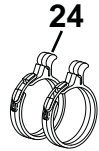
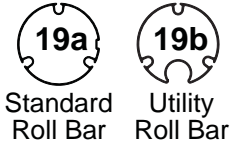
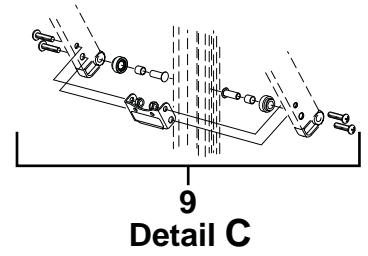
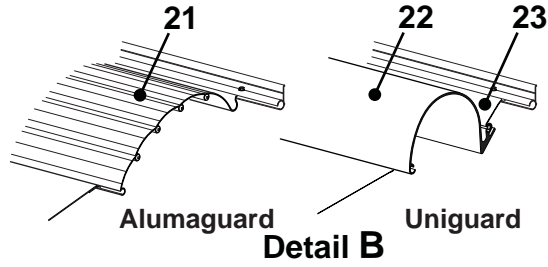

Detail A
After Market
Top Bracket

E0501sm

Item	Part Number	Description	Notes
1	Contact Carefree	1/2 Set Hardware, Arm Assy, Motorized, RH	Standard 3
2	for Order	1/2 Set Hardware, Arm Assy, Idler, RH	Standard 3
	Information	NOTE: 1/2 Set Arm Assemblies for XL are no longer available.	
3	R001099	Gas Shock	42.5" extended length (clevis to clevis)
	R001253	Shock Hardware Kit	
4	R001100XXX	Cap, Rail Top	
5	R014635-251	Top Extension Kit (aftermarket installations only)	White 4
	R014635-JV1	Top Extension Kit (aftermarket installations only)	Black 4
5a	R001094XXX	Top Mounting Bracket (aftermarket installation only)	
6	R001102XXX	Fascia	
	R001102XXX-XL	Fascia for XL	
7	R001103XXX	Fascia Cap, No Switch	
8	R001101	Hinge Bracket Kit	
9	R019291-005	Arm Roller Kit	White
	R019291-006	Arm Roller Kit	Black
10	901008	Rubber Bumper	
11	R001110XXX	Cap, Channel, Bottom	
12	R001111XXX	Cap, Channel, Top	
13	R001104XXX	Motor Assy	
14	R001323	Kit, Head Attach Hardware	
15	R060414-00X	Motor Cable	
16	R001324XXX	Kit, Motor Cover	
17	R001107XXX	Idler Assy	Standard 2
18	R001325XXX	Kit, Idler Cover	2
19a	19xx00	Roller Tube, 4-Slot, No LED	3 1/2" Dia
	19xx00RB	Roller Tube, 4-Slot, w/ White LED	3 1/2" Dia
19b	15xx00A	Roller Tube, w/ Utility Slot	3 1/2" Dia
20		Canopy	Refer to Canopy Order Form
21	20xxx36XXX	Alumaguard Assembly Only	
22	R001246XXX-xxx	Uniguard (includes 4.25" soft connect)	
	R001246XXX-xxxT	Uniguard (includes 5.25" soft connect)	
23	R001247XXX-xxx	Soft Connect	4.25" Wide
	R001247XXX-xxxT	Soft Connect	5.25" Wide
24	901067	Tractioner Kit	pkg of 2
	R001008	O-Ring, Tractioner Retainer	pkg of 2
25	R001509	Owners Kit: Jumper Cable, Manual & Hex Key	not shown
26	R019404-002	Jumper Harness Kit	not shown
27	041223-006	Foam Tape, Black	not shown
	041223-005	Foam Tape, White	not shown

- NOTES:**
1. XXX = Color; xxx = Length in inches.
 2. Cover kits include front cover, rear cover and attaching screws.
 3. After 01-01-2011 all replacement arms will have a 60 7/8" rear extrusion. Aftermarket arms will include item 5 (top extension kit). This change does not affect existing mounting hole locations.
 4. Top extension kit (item 5) includes top mounting bracket (item 5a)

Electronics

Single Switch Kit

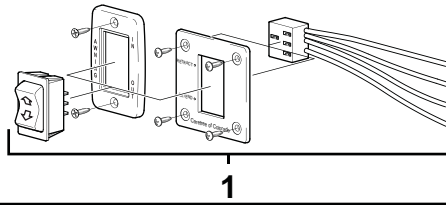

Multi-Switch Electronics

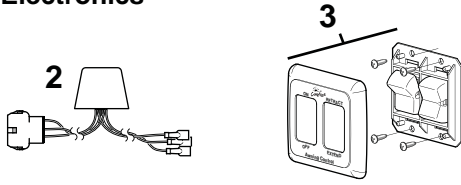

Battery

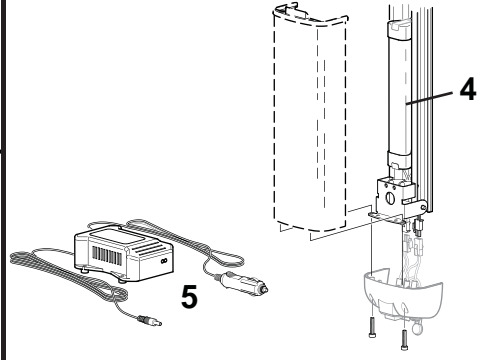

Factory Installed Direct Response (OEM)

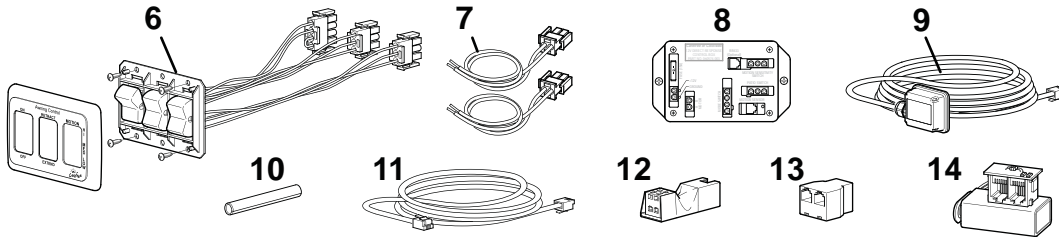

Remote (see notes)

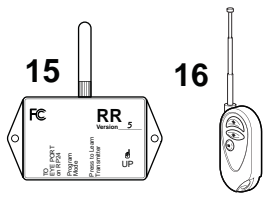

Factory Installed LED Lighting

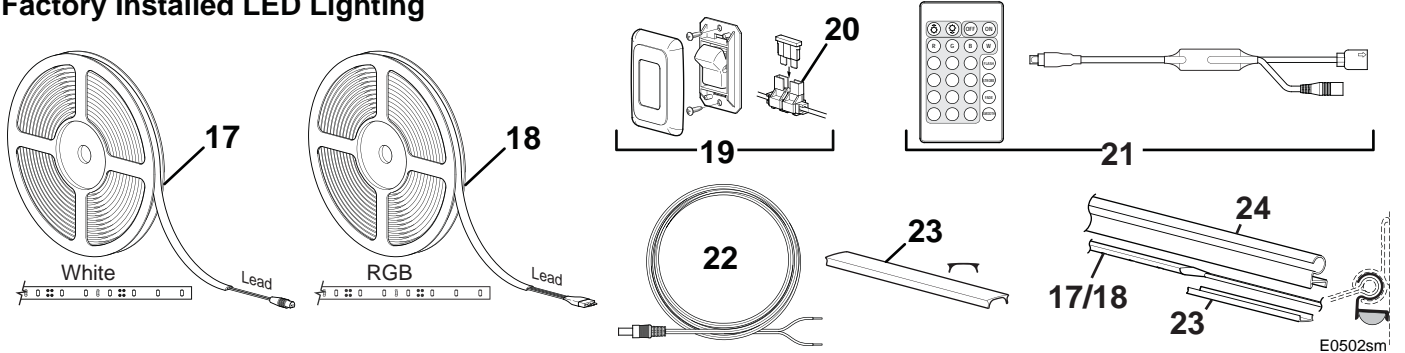

Item	Part Number	Description	Notes
1	R001605	Kit, Single Switch	1
2	R001112	Relay Module	Multi-Switch
3	R019468-006	Kit, Multiple Switch	Multi Switch 2
4	R001098	Battery	Battery Configuration Only
5	R001097	Battery Charger	Battery Configuration Only
6	R019489-001	Switch Kit, Direct Response	3,4
7	R060345-001	Harness - Power, Motor Connect	4
8	R060574-003	Controller	4,7
9	R060538-002	Sensor w/ Cable	4
10	R040562-001	Cord Retainer	4
11	R060434-001	Phone Cable, 60"	4
12	R060532-001	Ignition Lockout Sensor, EL	6
13	R060589-001	Splitter	Used with Ignition Lockout
14	SR0095	Sensor Test Tool	
15	R060429-002	RF Remote Receiver, 433 MHz, Version 5	5
16	R060622-001	Key FOB, Remote, 433 MHz, Version 5	5
17	R001714	LED Strip, White, Short Lead	Used with 18' or shorter 8,9
	R001715	LED Strip, White, Long Lead	Used with 19' and longer 8,9
18	R060733-001	LED Strip, RGB, Short Lead	Used with 18' or shorter 8,9,10
	R060733-002	LED Strip, RGB, Long Lead	Used with 19' and longer 8,9,10
19	SR0101	Switch Kit (includes item 5)	Used with white LED
20	R019493-001	Fuse Kit (includes in-line fuse holder and 2A fuse)	
21	SR109	Remote and Mini Controller Kit	Used with RGB LED 11
22	R060740-001	Harness, LED Power	
23	R001716	Slot Cover	2'
24	R001764-xxx	LED Awning Rail Adaptor	12

- NOTES:**
- Switch kit (item 1) includes switch, faceplates, screws and connector and replaces all previous single switch kits. Components not available separately.
 - Switch kit (item 3) includes switches, faceplate and screws and replaces all previous multi switch kits. Components not available separately.
 - Switch kit (item 6) includes switches w/ harnesses, faceplate and screws and replaces all previous multi switch kits for direct response. Components not available separately.
 - A Direct Response upgrade kit (p/n SR0036) is available and contains items 6 thru 11.
 - Key FOB and Receiver must match in frequency (418 MHz or 433 MHz). 418 MHz receivers are marked "RR24" and have a blue band or no band around the antenna. 433 MHz receivers are marked "RR" and have a red band around the antenna.
Key FOBs marked version 4 must be used with receivers marked version 4.
Remote Receiver marked Version 5 is compatible with all remotes marked Version 2 thru 5.
 - The optional Ignition Lockout Sensor can only be used with controller boxes (item 11) that are marked with 060574-003. Sensor does not work with boxes marked with -001 or -002.
 - The controller box (item 11) marked with 060574-003 is backward compatible and can be used for replacement of all previous versions marked with -001 and -002.
 - LED strip (items 17, 18) is sent on a roll and cut to length during installation.
 - White and RGB LED strips are not interchangeable.
 - RGB LEDs (item 18) are only available for awning rail adaptor installations.
 - Remote and controller kit (item 19) are used with RGB installations only.
 - Awning rail adaptor (item 22) requires the canopy to have a 3/16" polyrod instead of the standard 1/4" polyrod at the awning rail.



OWNER'S MANUAL

ECLIPSE

MODEL YEARS 2008 AND EARLIER

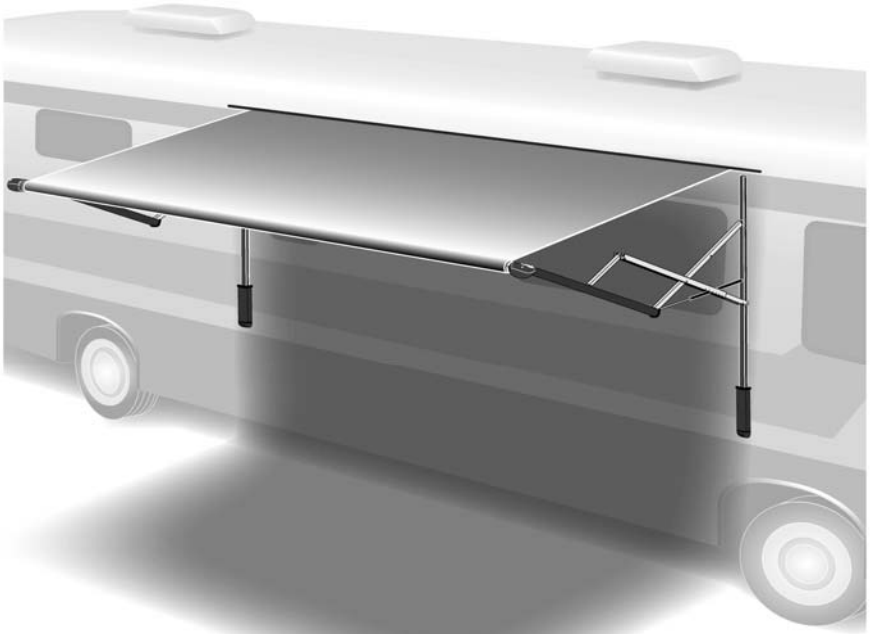

Special Note: This manual provides a basic description of the product and the standard operating controls provided by Carefree of Colorado. Some Original Equipment Manufacturers (OEM's) may alter or change the placement, style and/or functional configuration of the switches. If your controls do not match the style or description included, contact the coach manufacturer for an accurate description. OEM furnished components are not covered by the Carefree warranty.

INTRODUCTION

From its beginning in the early 70's, Carefree of Colorado has emerged as the premier manufacturer of quality awnings and accessories for Recreational Vehicles (RVs). Our full line of products can provide the accessories that match your life style; no matter what type of RV you own.

The Eclipse Patio Awning uses unique "scissor" style arms that do not require vertical ground support. The arms provide easy to use pitch adjustment—simply push together the pins on the arms, snap into the hole set desired, and the pitch is set! The pitch can be left in any position and the Eclipse will roll up completely! When the awning is rolled back out, it rolls out to pitch setting previously set.

Features include:

- The awning rollbar and arms are made from light weight, no-rust aluminum;
- 100% billow-proof, worm-gear drive motor eliminates the need for travel locks;
- Highest head clearance of any vertical arm awning;
- Automatic Self-Leveling Retraction from any pitch;
- Large selection of vinyl and Acrylic fabrics and fabric covers.

Consult your Carefree Dealer for available options and upgrades.

This manual describes the operation and care for your Eclipse Patio Awning. Descriptions include: Single Switch Operation; Multiple Switch Operation that includes a convenient outdoor patio switch; the optional auto-retract system that closes the awning automatically in windy conditions; and, the battery operated Eclipse (the battery operated Eclipse has been discontinued for 2007).

Operational Notes:

Awning Motor The awning motor is equipped with a thermal protection circuit to protect the motor from overheating. Operating the awning repeatedly over a short time period may cause the circuit to sense a overheat condition and shut off the motor. If this occurs, wait approximately 15 minutes to allow the motor to cool then operate the awning in normal fashion.

Ignition Lockout Sensors (Available with Direct Response Only): If the optional Carefree EL ignition lockout is installed the system will disable the extend function while the vehicle ignition key is in the ON position.

Special order RTL ignition lockouts will fully retract the awning and disable the extend function when the vehicle ignition key is in the ON position.

Functions will return to normal operation when the ignition key is turned OFF.

RV manufacturers may install their own lockout design. Refer to the RV literature for 12V power used for accessories.

⚠WARNINGS

⚠ AWNINGS ARE DESIGNED TO PROVIDE SHADE AND PROTECTION FROM THE SUN. THE EFFECTS OF WIND AND RAIN ON AN AWNING ARE UNPREDICTABLE AND CAN CAUSE SEVERE DAMAGE TO THE AWNING AND/OR THE VEHICLE. IF WIND OR EXTENDED PERIODS OF RAIN ARE EXPECTED, ROLL UP THE AWNING AND SECURE.

⚠ KEEP ALL SOURCES OF HEAT AND FLAME AWAY FROM THE AWNING CANOPY. FABRIC IS NOT FIRE-PROOF AND CAN BURN IF LEFT IN CONTACT WITH ANY FLAME OR HEAT SOURCE.

⚠ CAUTION It is recommended that if leaving the RV unattended for a length of time, retract the awning to avoid unexpected climate conditions.

SINGLE SWITCH OPERATION

For basic installations, a single interior control switch is provided for Extend and Retract motor control.

To Operate the Awning: Press and hold the Patio Switch until the awning is in the desired position then release the switch.

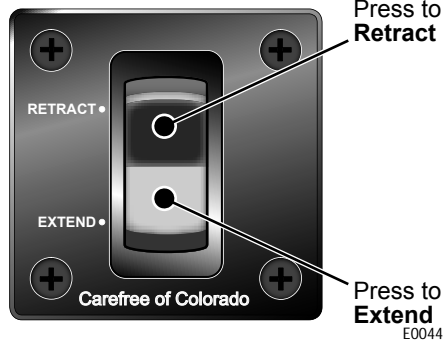

E0044

MULTIPLE SWITCH OPERATION

The multiple switch configuration provides 3 switches for Extend and Retract Motor control. Two interior switches, a Power ON/OFF and a Patio switch. A second outside Patio switch is mounted into the bottom cover of the right arm.

To Operate the Awning:

- Press the Power Switch to the ON position.
- Press and hold a Patio Switch until the awning is in the desired position then release the switch.

⚠ CAUTION

IT IS STRONGLY RECOMMENDED THAT THE POWER SWITCH BE SET TO OFF WHENEVER THE AWNING IS NOT BEING OPERATED AND DURING TRANSPORT. THIS ACTS AS A SAFETY TO PREVENT THE AWNING FROM BEING ACCIDENTLY OPENED.

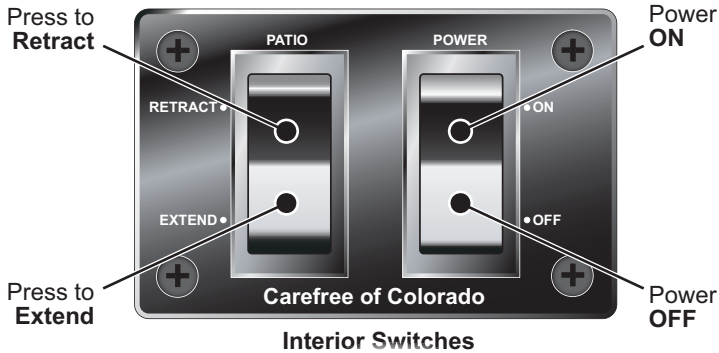

Interior Switches

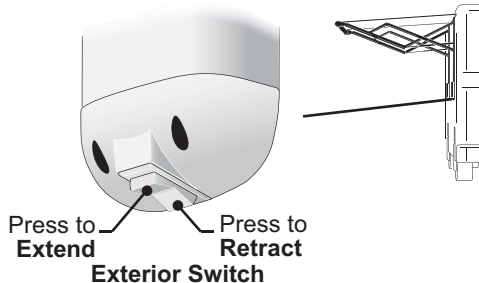

Exterior Switch

SYSTEMS WITH OPTIONAL AUTO-RETRACT

The Optional Auto-Retract System is an exciting enhancement to basic awning operation. When activated, the system will retract the awning automatically in windy conditions. Sensitivity is set at the control panel. Two systems are available for the Eclipse Patio Awning:

WindSmart – This system uses an anemometer to measure wind speed. The electronic control box responds by closing the awning when the wind speed reaches the selected wind speed value. The pushbutton controls allow the user to choose between 3 factory preset sensitivity values (wind speed). This system has been discontinued for 2008 and later models.

Direct Response – The system uses a sensor in the motor head to detect awning motion caused by windy conditions. The system operates by gauging the vertical motion of the awning's leading edge. When persistent motion exceeds the factory preset threshold value for 2 seconds or longer, the system will automatically retract the awning. The pushbutton controls allow the user to choose between 3 factory preset sensitivity values (threshold values).

Gust detection is incorporated into the Direct Response software. When the motion value is suddenly and sharply increased above a safe maximum value, then the 2 second persistence measure is overridden and the awning closes immediately.

⚠ CAUTION

THE CAREFREE DIRECT RESPONSE SYSTEM AND WINDSMART AUTO-RETRACT SYSTEM ARE PREMIERE ELECTRONIC AUTO-RETRACT SYSTEMS THAT PROVIDES PROTECTION AGAINST ADVERSE ELEMENTS; BUT, NO AUTO-RETRACT SYSTEM IS A GUARANTEE AGAINST SEVERE OR DESTRUCTIVE WEATHER; THE EFFECTS OF WIND AND RAIN ON AN AWNING ARE UNPREDICTABLE AND MAY CAUSE SEVERE DAMAGE TO THE AWNING AND/OR VEHICLE. IF WIND OR EXTENDED PERIODS OF RAIN ARE EXPECTED, RETRACT THE AWNING.

DESCRIPTION OF CONTROLS

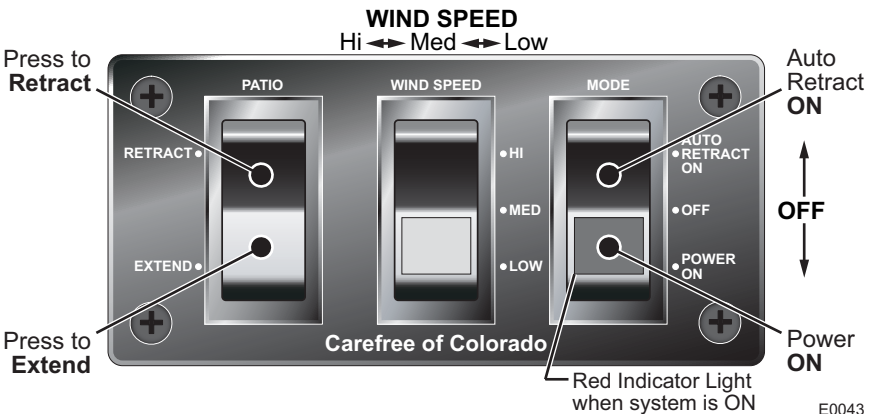

MODE SWITCH

OFF.....The center position shuts the system down. The awning cannot be extended or retracted in this mode. The auto-retract system is also disabled.



CAUTION

IT IS STRONGLY RECOMMENDED THAT THE POWER SWITCH BE SET TO OFF WHENEVER THE AWNING IS NOT BEING OPERATED AND DURING TRANSPORT. THIS ACTS AS A SAFETY TO PREVENT THE AWNING FROM BEING ACCIDENTLY OPENED.

POWER ONThe bottom position activates the patio switch and provides power to the awning.

AUTO-RETRACT ON...The top position activates the patio switch and the Auto-Retract system and provides power to the awning.

When the switch is placed in the POWER ON or Auto-Retract ON position, the switch will illuminate to indicate the system is active.

PATIO SWITCH

This is a two position momentary contact switch. This description also applies to Eclipse models with an exterior switch or any additional patio switches that may be installed.

EXTENDPress and release the switch. The awning automatically opens. To stop the awning before it is open, press and release the extend switch a second time; or, switch the MODE switch to the OFF position.

RETRACTPress and release the switch. The awning automatically retracts until it is fully closed. To stop the awning before it is closed, press and release the retract switch a second time; or, switch the MODE switch to the OFF.

SENSITIVITY SWITCH

HI.....Hi is the least sensitive and responds to winds approximately equal to 12 mph.

MEDMedium responds to winds approximately equal to 9 mph.

LOW.....Low is the most sensitive and responds to winds approximately equal to 6 mph.

NOTE: If the sensitivity switch is not installed, the system defaults to the medium setting.

OPERATING THE CONTROLS

For Standard operation:

- Set the MODE switch to POWER ON or AUTO-RETRACT ON.
- Press and release the Patio Switch to extend or retract the awning.

To activate the Auto-Retract:

- Set the MODE switch to AUTO-RETRACT ON and set the WIND SPEED (sensitivity) switch to the desired level.

TESTING THE DIRECT RESPONSE SYSTEM

It is important to test the Direct Response system periodically to ensure that the system is working properly. Follow the simple test below.

1. Extend the awning completely.
2. Turn the mode switch to Auto-Retract ON. Set the sensitivity to the lowest setting.
3. Gently move the roller tube up and down in a vertical motion.
4. If the awning retracts, the system is working properly.
5. If the awning does not retract, contact an authorized Carefree dealer for repairs. Operate the awning with the Patio switch until the system is repaired.

USING THE KEY FOB REMOTE CONTROL

A remote control Key FOB is available only with the auto-retract systems. To use: turn system power ON. The remote provides the advantage of allowing you to operate the awning from any convenient location.

Two remote styles are used with the Eclipse auto-retract systems. The 418 MHz transmitter is a flat Key FOB type and the 433 MHz transmitter both work in the same manner.

The remote has a maximum operating range of 50 feet. Actual distance may vary depending on the specific installation and location of the receiver in the vehicle.

To use: turn system power ON at the control panel.

NOTE: Power ON/OFF and the Auto-Retract system and can only be operated at the control panel.

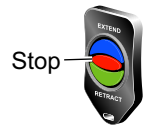

418 MHz



433 MHz
DR021

Extend... Press and release. The awning will extend out to the full extension and stop automatically.

Retract... Press and release. The awning will retract and stop automatically when the awning is fully retracted.

Stop..... Press and release. During extend and retract functions, the awning may be stopped by pressing this button.

KEY FOB BATTERIES

The Gray Button remote uses a flat 3V Lithium Battery (p/n CR2032) that should provide a long period of service. To access: carefully pry off the back of the case. Lift the circuit board out then slide the old battery out of the battery holder and slide a new battery in. The + should face away from the circuit board.

The Key FOB w/ antenna uses a battery (Radio Shack p/n 23-279 or equivalent) that should provide a long period of service. To access: Remove the small screw from the back of the case and carefully snap off the back. Lift the old battery out and insert the new battery.

Batteries are available through your local battery outlets.

Battery life is dependent on frequency of use, environmental conditions and condition of remote.

PROGRAMMING THE REMOTE RECEIVER

Early transmitters & receivers operate on a frequency of 418MHz. Models for 2007 & on operate on 433MHz. Identifying the frequency is described under the operational notes below.

1. Power to the control box must be on.
2. Press and release the "Press to Learn Transmitter" button on the bottom of the receiver box. The receiver is in program mode when the red light comes on.
3. For Gray Button Key FOBs: Press and release ANY button on the remote. It is recommended to use the STOP button. The red light will go out after the receiver learns the remote signal.

CAUTION

FOR THE GRAY BUTTON REMOTES, IF A FUNCTION BUTTON IS PRESSED DURING THE LEARNING PHASE, THE RECEIVER LEARNS THE TRANSMITTER SIGNAL THEN THE AWNING WILL THEN PERFORM THE FUNCTION. USE CARE TO AVOID UNEXPECTED AWNING MOVEMENT.

4. For Key FOBs w/ Antenna: Press and release the STOP button on the remote. The red light will go out after the receiver learns the remote signal.

NOTE: Pressing the stop button will cause the blue up arrow button to default as the close (retract) function.

If a function button is pressed to train the receiver, it will be programmed as the retract button. Example: Pressing the bottom button will program the bottom button for retract and the top button as extend.

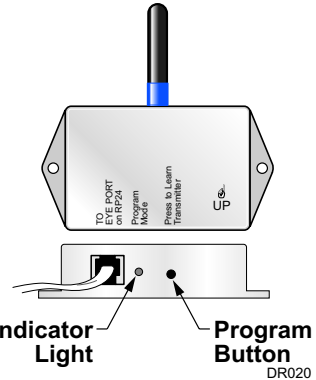

OPERATIONAL NOTES:

- Transmitter and receiver must match in frequency (418 MHz or 433 MHz).

Gray button Key FOBs are marked with a label for 418MHz or 433MHz frequency. Key FOBs w/ antenna are 433MHz.

418 MHz receivers are marked "RR24". 433 MHz receivers are marked "RR"

- The receiver exits the program mode after ten seconds.
- If the light does not come on, the memory is full and must be cleared.
- If the light does not go out in above, the receiver already knows the transmitter's signal or the battery in the remote needs to be replaced.
- To clear the memory: **PRESS AND HOLD** the transmitter learn button. While holding the button, the indicator light should be OFF for the full 5 seconds then come on.
- The system may be programmed for up to 5 remotes. Additional remotes may be ordered separately.

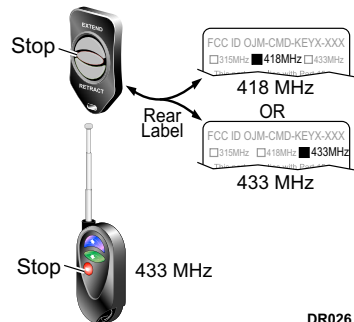

OPTIONAL BATTERY POWER

The following reference information is for awnings built prior to 2007. The battery operated Eclipse has been discontinued.

The Eclipse battery configuration uses one exterior switch, located on the bottom of the right arm; and, one rechargeable 14.4V NiCd battery pack located in the right arm.

To Operate the Awning: Press and hold the Exterior Switch until the awning is in the desired position then release the switch.

CHARGING THE BATTERY

The battery is a NiCd rechargeable battery designed to provide years of reliable service provided that a few simple rules are followed.

- Always discharge the battery completely by operating the awning before recharging. DO NOT charge the battery after every use.
 - Always charge the battery fully. Do not partially charge the battery.
 - Do not operate the awning while the battery is charging. If it is necessary to operate the awning before the battery is fully charged, disconnect the charger first to prevent possible damage to the charger.
 - If the awning is operated while the charger is plugged in, the charger will falsely report a full battery charge. It will be necessary to reset the charger by unplugging the power cord, wait 10 seconds and reconnect.
 - Do not leave the charger plugged into the battery without the power cord plugged in. This can cause the battery to discharge through the charger. Damage to the battery can occur over extended periods.
1. Connect the charger to the vehicle's 12 volt auxiliary outlet.
NOTE: Several commercially available converters are available to operate the charger from a standard 110VAC wall outlet. Converter is not furnished with awning but is available through local electronic stores.
 2. Connect the charger to the battery through the battery receptacle. The receptacle is located next to the switch on the bottom of the right arm.
 3. Observe the LEDs located on the side of the charger. When the green LED stays steady on, the battery is fully charged. Disconnect the charger.

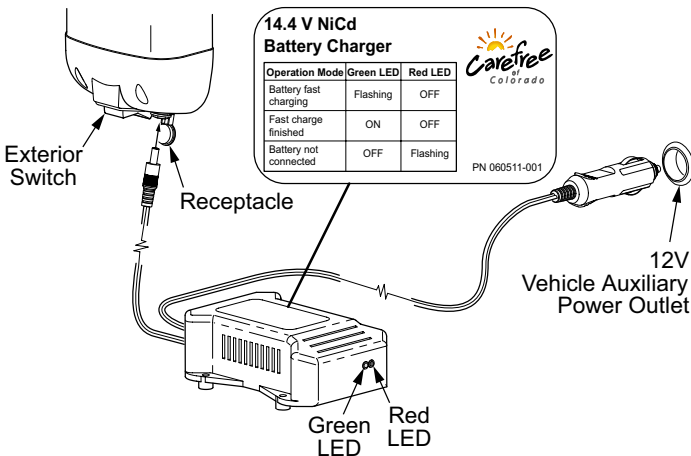

ADJUSTING THE PITCH

The Eclipse arms have 6 pitch adjustment settings from minimum pitch (setting #1) to maximum pitch (setting #6). The awning can be extended and retracted in any of these positions without having to reset the pitch between uses.

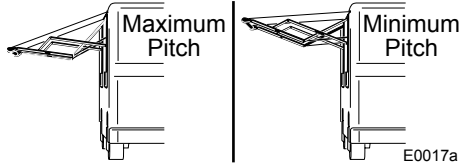

⚠ CAUTION

BE CAREFUL WHEN ADJUSTING THE PITCH AS THE AWNING MAY MOVE ABRUPTLY.

1. Extend the awning completely. It is easier to adjust the pitch when the awning is fully extended.
2. Hold on to the arm of the awning to keep it steady while adjusting the pitch.
3. Press the pitch adjustment pins, located on the long scissor arm. There are two pins: one in the outer channel (shown) and one in the inner channel.

Tip: Applying LIGHT pressure on the arm will decrease the force required to press the pitch adjustment pins.

4. Slide the outer scissor arm to the desired set of holes—towards the coach for a lower pitch and away from the coach for a higher pitch.

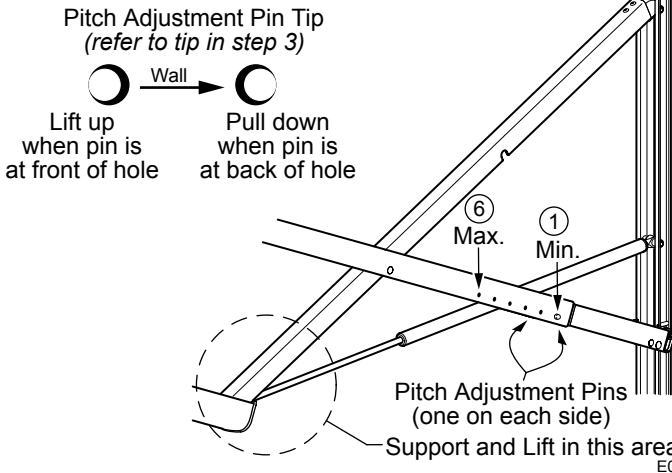

RAIN RELEASE SETTING

The effects of wind and rain on an awning are unpredictable. Severe damage to the awning and/or the vehicle may result. IF WIND OR EXTENDED PERIODS OF RAIN ARE EXPECTED, ROLL UP THE AWNING AND SECURE.

If the awning is extended during rain, position one arm at minimum pitch and the other arm at maximum pitch. This provides slope to allow the water to run off.

Note: The awning can be retracted with the arms set in the release setting. The pitch does not have to be equalized before closing.

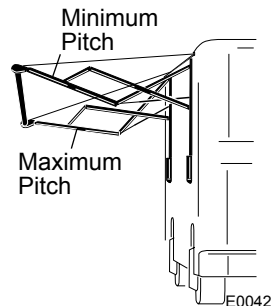

EMERGENCY OPERATION

If the original power source fails or is unavailable, the Eclipse has emergency override terminals (12V). The terminals can be used with a 9V-18V power source, such as a cordless drill battery or car battery.

⚠WARNING

DO NOT CONNECT THE ECLIPSE TERMINALS TO A 110V POWER SOURCE! DOING SO WILL PERMANENTLY DAMAGE THE AWNING!

To use the emergency terminals:

⚠CAUTION

DO NOT USE THE EMERGENCY TERMINALS WITHOUT FOLLOWING THE DIRECTIONS BELOW. THE ELECTRONIC CIRCUIT CREATES A DYNAMIC BRAKE FOR THE MOTOR BY SHORTING AND GROUNDING THE MOTOR LEADS. STEPS 1 & 2 REMOVE THE BRAKE TO ALLOW THE EMERGENCY OVERRIDE TO WORK.

1. If there is an external plug, disconnect the plug, then go to step 3.
2. Awnings without an external plug:
 - 2.1 Remove the front cover from the motor head. There are six (6) small screws, do not remove the larger screw toward the center.
 - 2.2 Disconnect the input cable wires from the terminals. **DO NOT** disconnect the wires to the motor.
 - 2.3 Leave the wires disconnected and reattach the front cover.
3. Attach the provided jumper leads to the terminals, located on the rear of the motorized head.
4. Connect the other ends of the jumper leads to a 12V source. If the awning does not begin to move, reverse the leads.
5. Maintain contact throughout the retraction process.

⚠CAUTION

BE CAREFUL WHEN RETRACTING THE AWNING AS THE AWNING MAY MOVE ABRUPTLY.

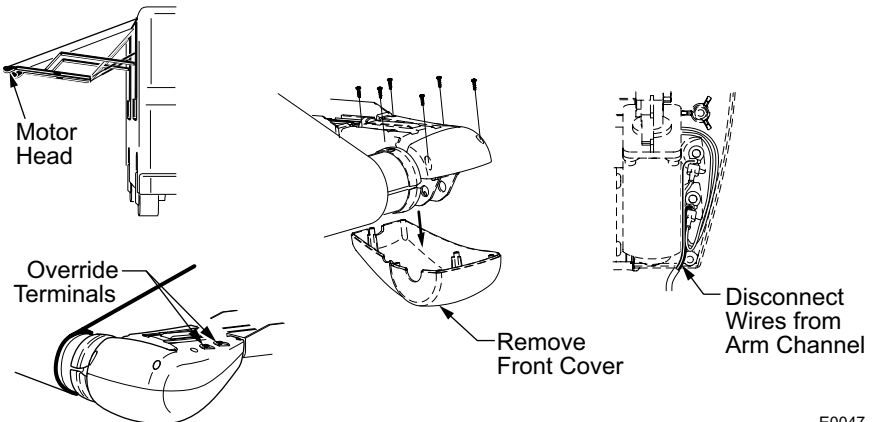

AWNING CARE

Maintaining a Carefree Awning is easy. Just follow these basic steps:

- Always operate the awning according to the instructions.
- Periodically check that the fasteners are tight. Tighten if necessary.
- Keep the awning fabric and arms clean.

FABRIC CARE

CAUTION

DO NOT USE OIL BASED CLEANERS OR ANY CAUSTIC, GRANULATED, OR ABRASIVE TYPE CLEANERS ON YOUR CAREFREE PRODUCT.

1. One of the best ways to keep the fabric looking good and to delay the need for deep or vigorous cleanings is to hose fabrics off on a monthly basis with clear water. This practice will help prevent dirt from becoming deeply imbedded in the fabric. In most environments, a thorough cleaning will be needed every two to three years.
2. When it's time for a thorough cleaning, the fabric can be cleaned while still on the awning frame.
 - For Vinyl Fabric – Use a soft brush and warm water with soap.
 - For Acrylic Fabric – Use a stiff brush and warm water with soap.
3. When cleaning the fabric, it is important to observe the following:
 - Always use a natural soap, never detergent.
 - Water should be cold to lukewarm, never more than 100°F.
 - Air-dry only. Never apply heat to the fabric.
 - Always allow the fabric to dry thoroughly before rolling up the awning.

MILDEW

Mildew is a fungus growth that looks like dirt. Vinyl coated polyester fabrics are mildew resistant because of a chemical biocide in the vinyl coating. Under ordinary conditions, mildew will not appear. However, in areas where high temperature and humidity are common, mildew can be a problem and require the material to be washed more frequently. Thoroughly rinse the fabric with clean water and allow to air dry completely before rolling up the awning.

POOLING

When water collects on the top of the fabric, this is known as "pooling". This can occur during inclement weather or if a running air conditioner discharges over the awning. The water is dumped when the awning is retracted. It is recommended that if water accumulates on the top; retract the awning in steps (8"-12") to dump the water. This will help prevent the fabric from stretching or distorting.

ARM CARE

The best method of keeping the arms operating smoothly is to clean them. Dirt and debris can cause the channels not to slide easily. **Avoid introducing water into the motorized and non-motorized housings.**

Periodically wash out the channels with running water (i.e. a hose) to keep them clean. If the arms still do not slide easily, lightly spray the pivot and contact points with a dry silicone lubricant after the arms have been cleaned and dried thoroughly.

MOTOR MAINTENANCE

- Check all wiring and connections for wear. Repair when needed.



OWNER'S MANUAL

ECLIPSE

MODEL YEAR 2009 & ON

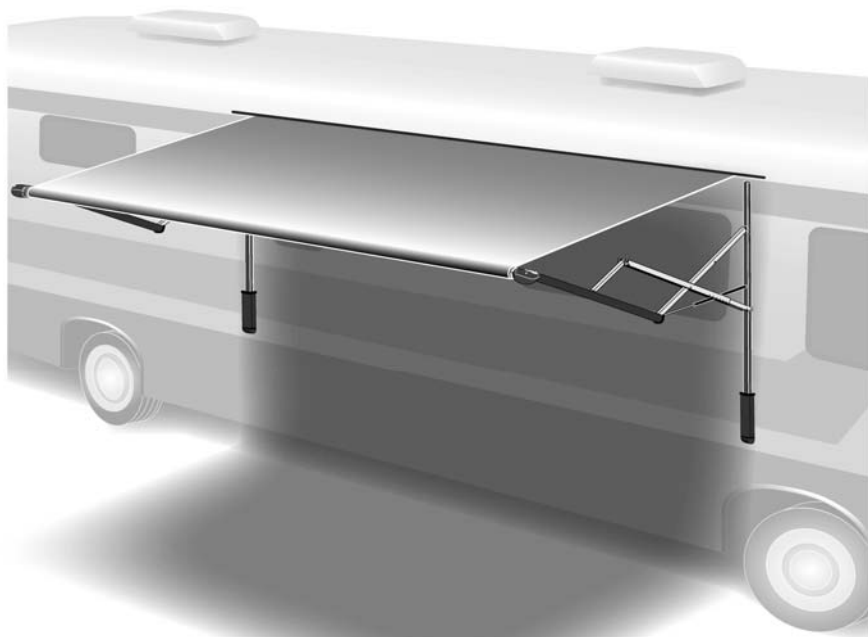

INTRODUCTION

From its beginning in the early 70's, Carefree of Colorado has emerged as the premier manufacturer of quality awnings and accessories for Recreational Vehicles (RVs). Our full line of products can provide the accessories that match your life style; no matter what type of RV you own.

The Eclipse Patio Awning uses unique "scissor" style arms that do not require vertical ground support. The arms provide easy to use pitch adjustment—simply push together the pins on the arms, snap into the hole set desired, and the pitch is set! The pitch can be left in any position and the Eclipse will roll up completely! When the awning is rolled back out, it rolls out to the pitch setting previously set.

Features include:

- The awning rollbar and arms are made from light weight, no-rust aluminum;
- 100% billow-proof, worm-gear drive motor eliminates the need for travel locks;
- Highest head clearance of any vertical arm awning;
- Automatic Self-Leveling Retraction from any pitch;
- Large selection of vinyl and Acrylic fabrics and fabric covers.

Consult your Carefree Dealer for available options and upgrades.

This manual describes the operation and care for your Eclipse Patio Awning. Descriptions include: Single Switch Operation; Multiple Switch Operation that includes a convenient outdoor patio switch; and, the optional auto-retract system that closes the awning automatically in windy conditions.

Operational Notes:

Awning Motor: The awning motor is equipped with a thermal protection circuit to protect the motor from overheating. Operating the awning repeatedly over a short time period may cause the circuit to sense a overheat condition and shut off the motor. If this occurs, wait approximately 15 minutes to allow the motor to cool then operate the awning in normal fashion.

Ignition Lockout Sensors (Available with Direct Response Only): If the optional Carefree EL ignition lockout is installed the system will disable the extend function while the vehicle ignition key is in the ON position. Special order RTL ignition lockouts will fully retract the awning and disable the extend function when the vehicle ignition key is in the ON position. Functions will return to normal operation when the ignition key is turned OFF.

RV manufacturers may install their own lockout design. Refer to the RV literature for 12V power used for accessories.

WARNINGS

 **AWNINGS ARE DESIGNED TO PROVIDE SHADE AND PROTECTION FROM THE SUN. THE EFFECTS OF WIND AND RAIN ON AN AWNING ARE UNPREDICTABLE AND CAN CAUSE SEVERE DAMAGE TO THE AWNING AND/OR THE VEHICLE. IF WIND OR EXTENDED PERIODS OF RAIN ARE EXPECTED, ROLL UP THE AWNING AND SECURE.**

 **KEEP ALL SOURCES OF HEAT AND FLAME AWAY FROM THE AWNING CANOPY. FABRIC IS NOT FIRE-PROOF AND CAN BURN IF LEFT IN CONTACT WITH ANY FLAME OR HEAT SOURCE.**

 **CAUTION** It is recommended that if leaving the RV unattended for a length of time, retract the awning to avoid unexpected climate conditions.

SINGLE SWITCH OPERATION

For basic installations, a single interior control switch is provided for Extend and Retract motor control.

To Operate the Awning: Press and hold the Patio Switch until the awning is in the desired position then release the switch.

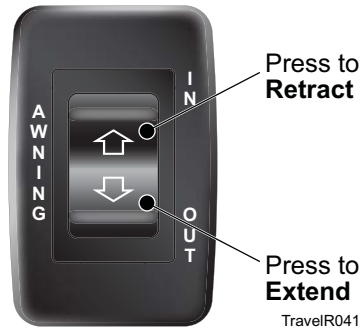

TravelR041

MULTIPLE SWITCH OPERATION

The multiple switch configuration provides 3 switches for Extend and Retract Motor control. Two interior switches, a Power ON/OFF and a Patio switch. A second outside Patio switch is mounted into the bottom cover of the right arm.

To Operate the Awning:

- Press the Power Switch to the ON position.
- Press and hold a Patio Switch until the awning is in the desired position then release the switch.

⚠ CAUTION

IT IS STRONGLY RECOMMENDED THAT THE POWER SWITCH BE SET TO OFF WHENEVER THE AWNING IS NOT BEING OPERATED AND DURING TRANSPORT. THIS ACTS AS A SAFETY TO PREVENT THE AWNING FROM BEING ACCIDENTLY OPENED.

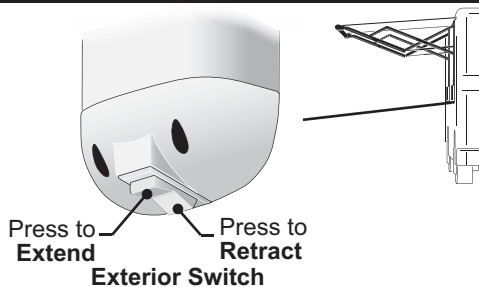
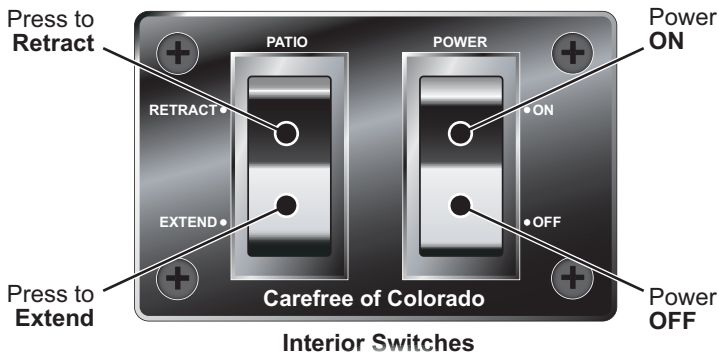

SYSTEMS WITH OPTIONAL AUTO-RETRACT

The Optional Auto-Retract System is an exciting enhancement to basic awning operation. When activated, the system will retract the awning automatically in windy conditions. Sensitivity is set at the control panel. Two systems are available for the Eclipse Patio Awning:

Direct Response – The system uses a sensor in the motor head to detect awning motion caused by windy conditions. The system operates by gauging the vertical motion of the awning's leading edge. When persistent motion exceeds the factory preset threshold value for 2 seconds or longer, the system will automatically retract the awning. The pushbutton controls allow the user to choose between 3 factory preset sensitivity values (threshold values).

Gust detection is incorporated into the Direct Response software. When the motion value is suddenly and sharply increased above a safe maximum value, then the 2 second persistence measure is overridden and the awning closes immediately.

⚠ CAUTION

THE CAREFREE DIRECT RESPONSE SYSTEM AND WINDSMART AUTO-RETRACT SYSTEM ARE PREMIERE ELECTRONIC AUTO-RETRACT SYSTEMS THAT PROVIDES PROTECTION AGAINST ADVERSE ELEMENTS; BUT, NO AUTO-RETRACT SYSTEM IS A GUARANTEE AGAINST SEVERE OR DESTRUCTIVE WEATHER; THE EFFECTS OF WIND AND RAIN ON AN AWNING ARE UNPREDICTABLE AND MAY CAUSE SEVERE DAMAGE TO THE AWNING AND/OR VEHICLE. IF WIND OR EXTENDED PERIODS OF RAIN ARE EXPECTED, RETRACT THE AWNING.

DESCRIPTION OF CONTROLS

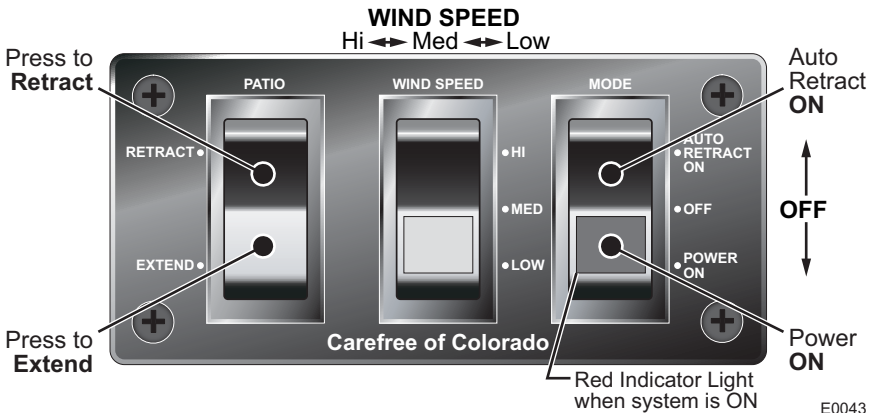

MODE SWITCH

OFF.....The center position shuts the system down. The awning cannot be extended or retracted in this mode. The auto-retract system is also disabled.



CAUTION

IT IS STRONGLY RECOMMENDED THAT THE POWER SWITCH BE SET TO OFF WHENEVER THE AWNING IS NOT BEING OPERATED AND DURING TRANSPORT. THIS ACTS AS A SAFETY TO PREVENT THE AWNING FROM BEING ACCIDENTLY OPENED.

POWER ONThe bottom position activates the patio switch and provides power to the awning.

AUTO-RETRACT ON...The top position activates the patio switch and the Auto-Retract system and provides power to the awning.

When the switch is placed in the POWER ON or Auto-Retract ON position, the switch will illuminate to indicate the system is active.

PATIO SWITCH

This is a two position momentary contact switch. This description also applies to Eclipse models with an exterior switch or any additional patio switches that may be installed.

EXTENDPress and release the switch. The awning automatically opens. To stop the awning before it is open, press and release the extend switch a second time; or, switch the MODE switch to the OFF position.

RETRACTPress and release the switch. The awning automatically retracts until it is fully closed. To stop the awning before it is closed, press and release the retract switch a second time; or, switch the MODE switch to the OFF.

SENSITIVITY SWITCH

HI.....Hi is the least sensitive and responds to winds approximately equal to 12 mph.

MEDMedium responds to winds approximately equal to 9 mph.

LOW.....Low is the most sensitive and responds to winds approximately equal to 6 mph.

NOTE: If the sensitivity switch is not installed, the system defaults to the medium setting.

OPERATING THE CONTROLS

For Standard operation:

- Set the MODE switch to POWER ON or AUTO-RETRACT ON.
- Press and release the Patio Switch to extend or retract the awning.

To activate the Auto-Retract:

- Set the MODE switch to AUTO-RETRACT ON and set the WIND SPEED (sensitivity) switch to the desired level.

TESTING THE DIRECT RESPONSE SYSTEM

It is important to test the Direct Response system periodically to ensure that the system is working properly. Follow the simple test below.

1. Extend the awning completely.
2. Turn the mode switch to Auto-Retract ON. Set the sensitivity to the lowest setting.
3. Gently move the roller tube up and down in a vertical motion.
4. If the awning retracts, the system is working properly.
5. If the awning does not retract, contact an authorized Carefree dealer for repairs. Operate the awning with the Patio switch until the system is repaired.

USING THE KEY FOB REMOTE CONTROL

A remote control Key FOB is available only with the auto-retract system. The remote provides the advantage of allowing you to operate the awning from any convenient location.

The remote has a maximum operating range of 50 feet. Actual distance may vary depending on the specific installation and location of the receiver in the vehicle.

To use: turn system power ON at the control panel.

NOTE: Power ON/OFF and the Auto-Retract system and can only be operated at the control panel.



Extend... Press and release. The awning will extend out to the full extension and stop automatically.

Retract... Press and release. The awning will retract and stop automatically when the awning is fully retracted.

Stop..... Press and release. During extend and retract functions, the awning may be stopped by pressing this button.

KEY FOB BATTERIES

The Key FOB w/ antenna uses a battery (Radio Shack p/n 23-279 or equivalent) that should provide a long period of service. To access: Remove the small screw from the back of the case and carefully snap off the back. Lift the old battery out and insert the new battery.

Batteries are available through your local battery outlets.

Battery life is dependent on frequency of use, environmental conditions and condition of remote.

PROGRAMMING THE REMOTE RECEIVER

When adding or replacing a remote control, it is necessary to program the transmitter and receiver.

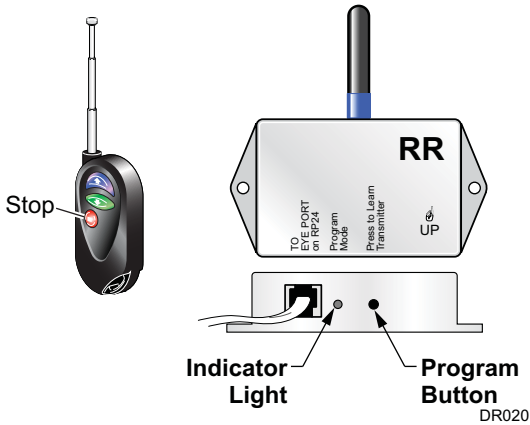

1. Power to the control box must be on.
2. Press and release the “Press to Learn Transmitter” button on the bottom of the receiver box. The receiver is in program mode when the red light comes on.
3. Press and release the STOP button on the remote. The red light will go out after the receiver learns the remote signal.

NOTE: Pressing the stop button will cause the blue up arrow button to default as the close (retract) function.

If a function button is pressed to train the receiver, it will be programmed as the retract button. Example: Pressing the top button will program the top button for retract and the bottom button as extend.

OPERATIONAL NOTES:

- Transmitter and receiver operate on frequency 433 MHz.
- The receiver exits the program mode after ten seconds.
- If the light does not come on, the memory is full and must be cleared.
- To clear the memory: PRESS AND HOLD the transmitter learn button. While holding the button, the indicator light should be OFF for the full 5 seconds then come on.
- If the light does not go out during programming, the receiver already knows the transmitter's signal or the battery in the remote needs to be replaced.
- The system may be programmed for up to 5 remotes. Additional remotes may be ordered separately.

ADJUSTING THE PITCH

The Eclipse arms have 6 pitch adjustment settings from minimum pitch to maximum pitch. The awning can be extended and retracted in any of these positions without having to reset the pitch between uses.

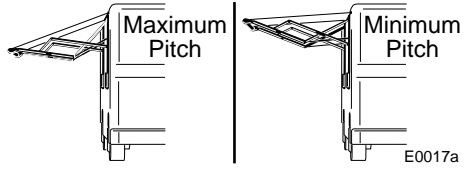

⚠ CAUTION

BE CAREFUL WHEN ADJUSTING THE PITCH AS THE AWNING MAY MOVE ABRUPTLY.

1. Extend the awning completely. It is easier to adjust the pitch when the awning is fully extended.
2. Hold on to the awning arm to keep it steady while adjusting the pitch.
3. Press the pitch adjustment pins, located on the long scissor arm. There are two pins: one in the outer channel (shown) and one in the inner channel.

Tip: Applying LIGHT pressure on the arm will decrease the force required to press the pitch adjustment pins.

4. Slide the outer scissor arm to the desired set of holes—towards the coach for a lower pitch and away from the coach for a higher pitch.

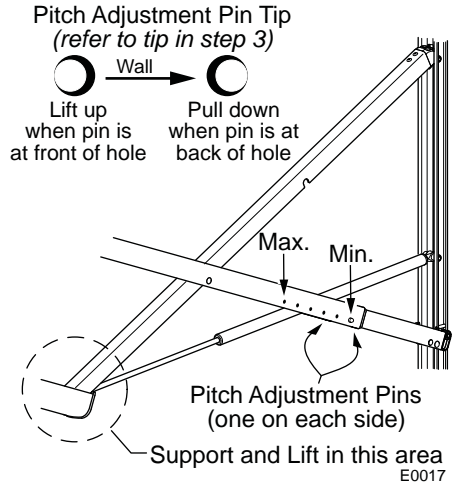

RAIN RELEASE SETTING

The effects of wind and rain on an awning are unpredictable and can cause severe damage to the awning and/or the vehicle. IF WIND OR EXTENDED PERIODS OF RAIN ARE EXPECTED, ROLL UP THE AWNING AND SECURE.

If the awning is extended during rain, position one arm at minimum pitch and the other arm at maximum pitch. This provides slope to allow the water to run off.

Note: The awning can be retracted with the arms set in the release setting. The pitch does not have to be equalized before closing.

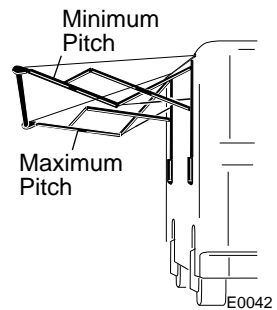

THE AUTO-DUMP FEATURE

When set at the MINIMUM (flat) pitch, the Eclipse awning will automatically dump accumulated water. The feature works by having one arm automatically folding partially closed to create a valley in the canopy. The valley allows the water to run off one side to prevent pooling. When the rain has stopped and the water has drained, the arm will extend back to normal.

This feature is disabled when accessories such as rafters or Add-A-Rooms are installed.

EMERGENCY OPERATION

If the original power source fails or is unavailable, the Eclipse has emergency override terminals (12V). The terminals can be used with a 9V-18V power source, such as a cordless drill battery or car battery.

⚠️ WARNING

DO NOT CONNECT THE ECLIPSE TERMINALS TO A 110V POWER SOURCE! DOING SO WILL PERMANENTLY DAMAGE THE AWNING!

To use the emergency terminals:

⚠️ CAUTION

DO NOT USE THE EMERGENCY TERMINALS WITHOUT FOLLOWING THE DIRECTIONS BELOW. THE ELECTRONIC CIRCUIT CREATES A DYNAMIC BRAKE FOR THE MOTOR BY SHORTING AND GROUNDING THE MOTOR LEADS. STEPS 1 & 2 REMOVE THE BRAKE TO ALLOW THE EMERGENCY OVERRIDE TO WORK.

1. If there is an external plug, disconnect the plug, then go to step 3.
2. Awnings without an external plug:
 - 2.1 Remove the front cover from the motor head. There are six (6) small screws, do not remove the larger screw toward the center.
 - 2.2 Disconnect the input cable wires from the terminals. DO NOT disconnect the wires to the motor.
 - 2.3 Leave the wires disconnected and reattach the front cover.
3. Attach the provided jumper leads to the terminals, located on the rear of the motorized head.
4. Connect the other ends of the jumper leads to a 12V source. If the awning does not begin to move, reverse the leads.
5. Maintain contact throughout the retraction process.

⚠️ CAUTION

BE CAREFUL WHEN RETRACTING THE AWNING AS THE AWNING MAY MOVE ABRUPTLY.

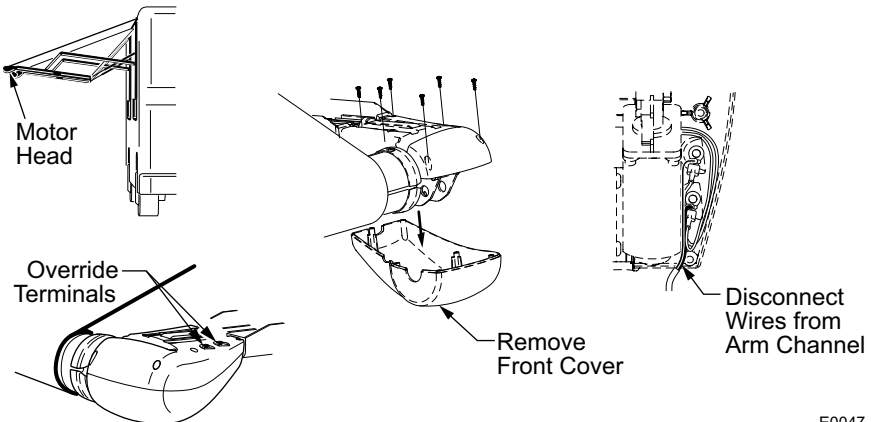

AWNING CARE

Maintaining a Carefree Awning is easy. Just follow these basic steps:

- Always operate the awning according to the instructions.
- Periodically check that the fasteners are tight. Tighten if necessary.
- Keep the awning fabric and arms clean.

FABRIC CARE

⚠ CAUTION DO NOT USE OIL BASED CLEANERS OR ANY CAUSTIC, GRANULATED, OR ABRASIVE TYPE CLEANERS ON YOUR CAREFREE PRODUCT.

1. One of the best ways to keep the fabric looking good and to delay the need for deep or vigorous cleanings is to hose fabrics off on a monthly basis with clear water. This practice will help prevent dirt from becoming deeply imbedded in the fabric. In most environments, a thorough cleaning will be needed every two to three years.
2. When it's time for a thorough cleaning, the fabric can be cleaned while still on the awning frame.
 - For Vinyl Fabric – Use a soft brush and warm water with soap.
 - For Acrylic Fabric – Use a stiff brush and warm water with soap.
3. When cleaning the fabric, it is important to observe the following:
 - Always use a natural soap, never detergent.
 - Water should be cold to lukewarm, never more than 100°F.
 - Air-dry only. Never apply heat to the fabric.
 - Always allow the fabric to dry thoroughly before rolling up the awning.

MILDEW

Mildew is a fungus growth that looks like dirt. Vinyl coated polyester fabrics are mildew resistant because of a chemical biocide in the vinyl coating. Under ordinary conditions, mildew will not appear. However, in areas where high temperature and humidity are common, mildew can be a problem and require the material to be washed more frequently. Thoroughly rinse the fabric with clean water and allow to air dry completely before rolling up the awning.

POOLING

When water collects on the top of the fabric, this is known as "pooling". This can occur during inclement weather or if a running air conditioner discharges over the awning. The water is dumped when the awning is retracted. It is recommended that if water accumulates on the top; retract the awning in steps (8"-12") to dump the water. This will help prevent the fabric from stretching or distorting.

LEAKING

On vinyl canopies, side hems and poly cords are stitched in with a sewing machine. On occasion, this stitching may allow water to seep or leak through the stitches. This is normal and not a defect covered by warranty. Treat the seams with a seam sealer.

ARM CARE

The best method of keeping the arms operating smoothly is to clean them. Dirt and debris can cause the channels not to slide easily. **Avoid introducing water into the motorized and non-motorized housings.**

Periodically wash out the channels with running water (i.e. a hose) to keep them clean. If the arms still do not slide easily, lightly spray the pivot and contact points with a dry silicone lubricant after the arms have been cleaned and dried thoroughly.



OWNER'S MANUAL

ECLIPSE

RV

MODEL YEAR 2010 & ON



Before operating the awning, carefully review the Owner's Manual. The manual contains important safety information, detailed operating instructions, common maintenance procedures and other useful information.



INTRODUCTION

From its beginning in the early 70's, Carefree of Colorado has emerged as the premier manufacturer of quality awnings and accessories for Recreational Vehicles (RVs). Our full line of products can provide the accessories that match your life style; no matter what type of RV you own.

The Eclipse Patio Awning uses unique "scissor" style arms that do not require vertical ground support. The arms provide easy to use pitch adjustment—simply push together the pins on the arms, snap into the hole set desired, and the pitch is set! The pitch can be left in any position and the Eclipse will roll up completely! When the awning is rolled back out, it rolls out to the pitch setting previously set.

Features include:

- The awning rollbar and arms are made from light weight, no-rust aluminum;
- 100% billow-proof, worm-gear drive motor eliminates the need for travel locks;
- Highest head clearance of any vertical arm awning;
- Automatic Self-Leveling Retraction from any pitch;
- Large selection of vinyl and Acrylic fabrics and fabric covers.

Consult your Carefree Dealer for available options and upgrades.

This manual describes the operation and care for your Eclipse Patio Awning. Descriptions include: Single Switch Operation; and, the optional auto-retract system that closes the awning automatically in windy conditions.

Operational Notes:

Awning Motor: The awning motor is equipped with a thermal protection circuit to protect the motor from overheating. Operating the awning repeatedly over a short time period may cause the circuit to sense a overheat condition and shut off the motor. If this occurs, wait approximately 15 minutes to allow the motor to cool then operate the awning in normal fashion.

Ignition Lockout Sensors (Available with Direct Response Only): If the optional Carefree EL ignition lockout is installed the system will disable the extend function while the vehicle ignition key is in the ON position. Special order RTL ignition lockouts will fully retract the awning and disable the extend function when the vehicle ignition key is in the ON position. Functions will return to normal operation when the ignition key is turned OFF. RV manufacturers may install their own lockout design. Refer to the RV literature for 12V power used for accessories.



WARNING

Awnings are designed to provide shade and protection from the sun. The effects of wind and rain on an awning are unpredictable and can cause severe damage to the awning and/or the vehicle. If wind or extended periods of rain are expected, roll up the awning.

NOTICE

It is recommended that if leaving the RV unattended for a length of time, retract the awning to avoid unexpected climate conditions.



WARNING

Keep all sources of heat and flame away from the awning canopy. Fabric is not fire-proof and can burn if left in contact with any flame or heat source.

NOTICE

If installed, LED lighting must be turned off when the awning is in the rolled up position. This is to prevent possible damage to the LEDs and/or canopy.

Special Note: This manual provides a basic description of the product and the standard operating controls provided by Carefree of Colorado. Some Original Equipment Manufacturers (OEM's) may alter or change the placement, style and/or functional configuration of the switches. If your controls do not match the style or description included, contact the coach manufacturer for an accurate description. OEM furnished components are not covered by the Carefree warranty.

SINGLE SWITCH OPERATION

For basic installations, a single interior control switch is provided for Extend and Retract motor control.

To Operate the Awning: Press and hold the Patio Switch until the awning is in the desired position then release the switch.

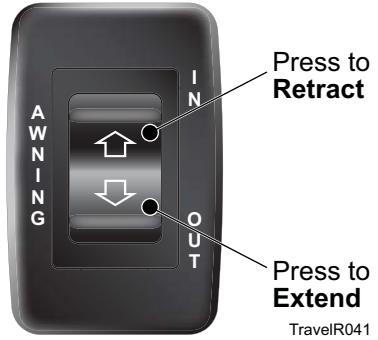

SYSTEMS WITH OPTIONAL AUTO-RETRACT

The Auto-Retract System is an exciting enhancement to basic awning operation. When activated, the system will retract the awning automatically in windy conditions. Sensitivity is set at the control panel.

The system uses a sensor in the motor head to detect awning motion caused by windy conditions. The system operates by gauging the vertical motion of the awning's leading edge. When persistent motion exceeds the factory preset threshold value for 2 seconds or longer, the system will automatically retract the awning. The pushbutton controls allow the user to choose between 3 factory preset sensitivity values (threshold values).

Gust detection is incorporated into the Direct Response software. When the motion value is suddenly and sharply increased above a safe maximum value, then the 2 second persistence measure is overridden and the awning closes immediately.



WARNING

The Carefree Direct Response auto-retract system is a premiere electronic auto-retract system that provides protection against adverse elements; but, no auto-retract system is a guarantee against severe or destructive weather; the effects of wind and rain on an awning are unpredictable and may cause severe damage to the awning and/or vehicle. If wind or extended periods of rain are expected, retract the awning.



WARNING

The power switch must be set to OFF whenever the awning is not being operated and during transport. This acts as a safety to prevent the awning from being accidentally opened.

DESCRIPTION OF CONTROLS

The Eclipse Awning with Direct Response uses 3 switches at the control panel. Power Switch; Patio Switch and Motion Sensitivity Switch.

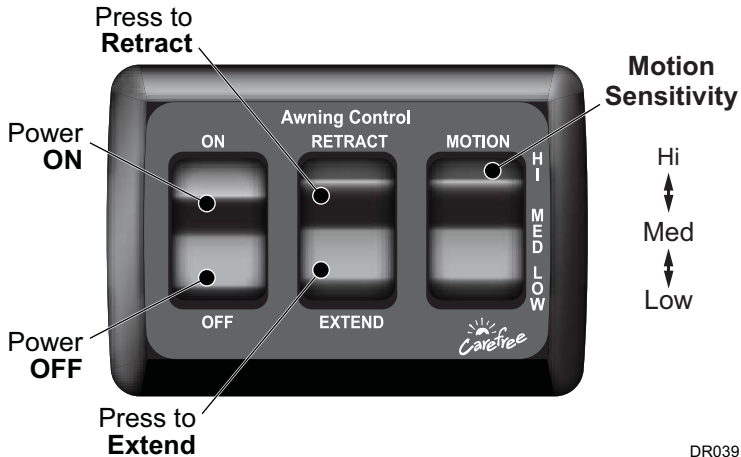

DR039

POWER SWITCH

POWER ONThe bottom position activates the Patio switch and the Auto-Retract system and provides power to the awning.

POWER OFFThe top position shuts the system down. The awning cannot be extended or retracted in this mode. The auto-retract system is also disabled.

IMPORTANT NOTE: The auto-retract system is ON when the power is ON. The system is OFF when the power switch is set to OFF. If the power is shut off while the awning is extended, the awning is not protected by the auto-retract system.

PATIO SWITCH

This is a two position momentary contact switch. This description also applies to any additional patio switches that may be installed.

EXTENDPress and release the switch. The awning automatically opens. To stop the awning before it is fully open, press and release the extend switch a second time.

RETRACTPress and release the switch. The awning automatically retracts until it is fully closed. To stop the awning before it is closed, press and release the retract switch a second time.

MOTION SWITCH

HIGH ↔ MED ↔ LOW

Low requires less amount of motion before the awning closes automatically. High requires more motion before the system closes automatically.

You may have to experiment to find the best setting for your preferences.

NOTE: If the motion switch is not installed, the system defaults to the medium setting.

OPERATING THE CONTROLS

- Turn the Power switch ON.
- Use the Patio switch to extend or retract the awning as desired.
- Set the Sensitivity switch to the level desired.

TESTING THE DIRECT RESPONSE SYSTEM

It is important to test the Direct Response system periodically to ensure that the system is working properly. Follow the simple test below.

1. Extend the awning completely.
2. Set the motion sensitivity to the lowest setting.
3. Gently move the roller tube up and down in a vertical motion.
4. If the awning retracts, the system is working properly.
5. If the awning does not retract, contact an authorized Carefree dealer for repairs. Operate the awning with the Patio switch until the system is repaired.

USING THE KEY FOB REMOTE CONTROL

A remote control Key FOB is available only with the auto-retract system. The remote provides the advantage of allowing you to operate the awning from any convenient location.

The remote has a maximum operating range of 50 feet. Actual distance may vary depending on the specific installation and location of the receiver in the vehicle.

To use: turn system power ON at the control panel.

NOTE: Power ON/OFF and the Auto-Retract system and can only be operated at the control panel.



Extend... Press and release. The awning will extend out to the full extension and stop automatically.

Retract... Press and release. The awning will retract and stop automatically when the awning is fully retracted.

Stop..... Press and release. During extend and retract functions, the awning may be stopped by pressing this button.

KEY FOB BATTERIES

The Key FOB w/ antenna uses a battery (Radio Shack p/n 23-279 or equivalent) that should provide a long period of service. To access: Remove the small screw from the back of the case and carefully snap off the back. Lift the old battery out and insert the new battery.

Batteries are available through your local battery outlets.

Battery life is dependent on frequency of use, environmental conditions and condition of remote.

PROGRAMMING THE REMOTE RECEIVER

When adding or replacing a remote control, it is necessary to program the transmitter and receiver.

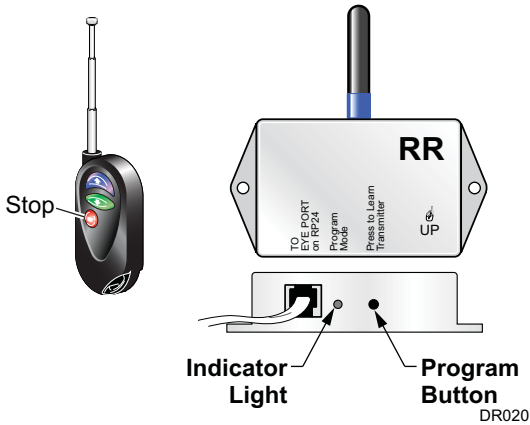

1. Power to the control box must be on.
2. Press and release the “Press to Learn Transmitter” button on the bottom of the receiver box. The receiver is in program mode when the red light comes on.
3. Press and release the STOP button on the remote. The red light will go out after the receiver learns the remote signal.

NOTE: Pressing the stop button will cause the blue up arrow button to default as the close (retract) function.

If a function button is pressed to train the receiver, it will be programmed as the retract button. Example: Pressing the top button will program the top button for retract and the bottom button as extend.

OPERATIONAL NOTES:

- Transmitter and receiver operate on frequency 433 MHz.
- The receiver exits the program mode after ten seconds.
- If the light does not come on, the memory is full and must be cleared.
- To clear the memory: PRESS AND HOLD the transmitter learn button. While holding the button, the indicator light should be OFF for the full 5 seconds then come on.
- If the light does not go out during programming, the receiver already knows the transmitter's signal or the battery in the remote needs to be replaced.
- The system may be programmed for up to 5 remotes. Additional remotes may be ordered separately.

ADJUSTING THE PITCH

The Eclipse arms have 6 pitch adjustment settings from minimum pitch to maximum pitch. The awning can be extended and retracted in any of these positions without having to reset the pitch between uses. See the NOTICES at the bottom of the page.

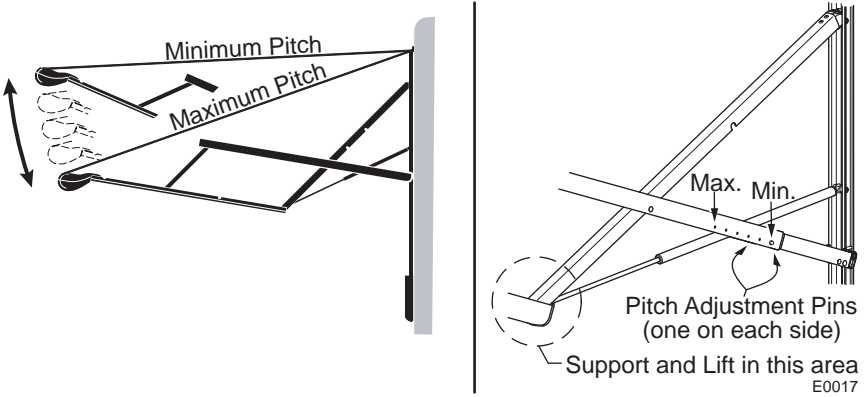

CAUTION

Use care when adjusting the pitch as the awning may move abruptly.

1. Extend the awning completely. It is easier to adjust the pitch when the awning is fully extended.
2. Hold on to the awning arm to keep it steady while adjusting the pitch.
3. Press in the pitch adjustment pins, located on the long scissor arms.

Tip: Applying LIGHT pressure on the arm will decrease the force required to press the pitch adjustment pins.

4. Slide the outer scissor arm to the desired set of holes—towards the coach for a lower pitch and away from the coach for a higher pitch.

NOTICE

For awnings under 12 feet long: Do not set the individual arm pitch at more than three (3) positions different between the left and right arm. Damage to the arms and canopy can occur if the awning is retracted when the arms are set at more than 3 positions difference.

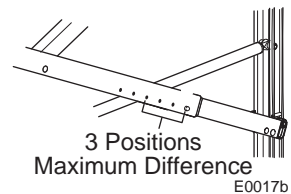

EMERGENCY OPERATION

If the original power source fails or is unavailable, the Eclipse has emergency override terminals (12V). The terminals can be used with a 9V-18V power source, such as a cordless drill battery or car battery.

⚠ WARNING **DO NOT CONNECT THE TERMINALS TO A 110V POWER SOURCE! DOING SO WILL PERMANENTLY DAMAGE THE AWNING!**

⚠ CAUTION Do not use the emergency terminals without following the directions below. The electronic circuit creates a dynamic brake for the motor by shorting and grounding the motor leads. Steps 1 & 2 remove the brake to allow the emergency override to work.

1. If there is an external plug, disconnect the plug, then go to step 3.
2. Awnings without an external plug:
 - 2.1 Remove the front cover from the motor head. There are six (6) small screws, do not remove the larger screw toward the center.
 - 2.2 Disconnect the input cable wires from the terminals. **DO NOT** disconnect the wires to the motor.
 - 2.3 Leave the wires disconnected and reattach the front cover.
3. Attach the provided jumper leads to the terminals, located on the rear of the motorized head.
4. Connect the other ends of the jumper leads to a 12V source. If the awning does not begin to move, reverse the leads.
5. Maintain contact throughout the retraction process.

⚠ CAUTION **Use care when retracting the awning as the it may move abruptly.**

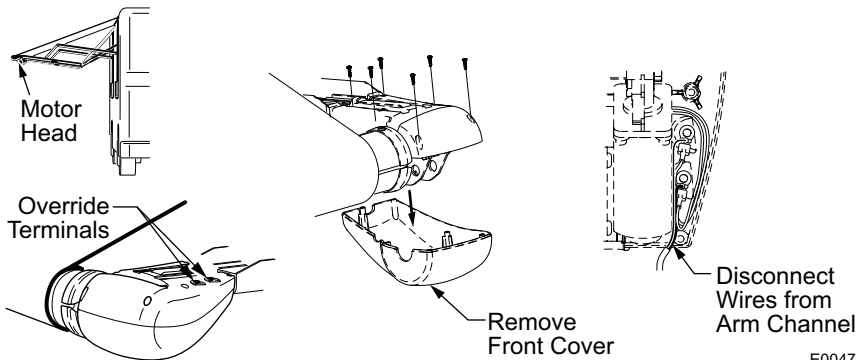

AWNING CARE

Maintaining a Carefree Awning is easy. Just follow these basic steps:

- Always operate the awning according to the instructions.
- Periodically check that the fasteners are tight. Tighten if necessary.
- Keep the awning fabric and arms clean.

FABRIC CARE

NOTICE Do not use oil based cleaners or any caustic, granulated, or abrasive type cleaners on your Carefree product.

1. One of the best ways to keep the fabric looking good and to delay the need for deep or vigorous cleanings is to hose fabrics off on a monthly basis with clear water. This practice will help prevent dirt from becoming deeply imbedded in the fabric. In most environments, a thorough cleaning will be needed every two to three years.
2. When it's time for a thorough cleaning, the fabric can be cleaned while still on the awning frame.
 - For Vinyl Fabric – Use a soft brush and warm water with soap.
 - For Acrylic Fabric – Use a stiff brush and warm water with soap.
3. When cleaning the fabric, it is important to observe the following:
 - Always use a natural soap, never detergent.
 - Water should be cold to lukewarm, never more than 100°F.
 - Air-dry only. Never apply heat to the fabric.
 - Always allow the fabric to dry thoroughly before rolling up the awning.

MILDEW

Mildew is a fungus growth that looks like dirt. Vinyl coated polyester fabrics are mildew resistant because of a chemical biocide in the vinyl coating. Under ordinary conditions, mildew will not appear. However, in areas where high temperature and humidity are common, mildew can be a problem and require the material to be washed more frequently. Thoroughly rinse the fabric with clean water and allow to air dry completely before rolling up the awning.

POOLING

When water collects on the top of the fabric, this is known as "pooling". This can occur during inclement weather or if a running air conditioner discharges over the awning. The water is dumped when the awning is retracted. It is recommended that if water accumulates on the top; retract the awning in steps (8"-12") to dump the water. This will help prevent the fabric from stretching or distorting.

LEAKING

On vinyl canopies, side hems and poly cords are stitched in with a sewing machine. On occasion, this stitching may allow water to seep or leak through the stitches. This is normal and not a defect covered by warranty. Treat the seams with a seam sealer.

ARM CARE

The best method of keeping the arms operating smoothly is to clean them. Dirt and debris can cause the channels not to slide easily. **Avoid introducing water into the motorized and non-motorized housings.**

Periodically wash out the channels with running water (i.e. a hose) to keep them clean. If the arms still do not slide easily, lightly spray the pivot and contact points with a dry silicone lubricant after the arms have been cleaned and dried thoroughly.



RV



Before operating the awning, carefully review the Owner's Manual. The manual contains important safety information, detailed operating instructions, common maintenance procedures and other useful information.



INTRODUCTION

From its beginning in the early 70's, Carefree of Colorado has emerged as the premier manufacturer of quality awnings and accessories for Recreational Vehicles (RVs). Our full line of products can provide the accessories that match your life style; no matter what type of RV you own.

The Eclipse Patio Awning uses unique “scissor” style arms that do not require vertical ground support. The arms provide easy to use pitch adjustment—simply push together the pins on the arms, snap into the hole set desired, and the pitch is set! The pitch can be left in any position and the Eclipse will roll up completely! When the awning is rolled back out, it rolls out to pitch setting previously set.

Features include:

- The awning rollbar and arms are made from light weight, no-rust aluminum;
- 100% billow-proof, worm-gear drive motor eliminates the need for travel locks;
- Highest head clearance of any vertical arm awning;
- Automatic Self-Leveling Retraction from any pitch;
- Large selection of vinyl and Acrylic fabrics and fabric covers.

Consult your Carefree Dealer for available options and upgrades.

This manual describes the operation and care for your Eclipse Patio Awning. Descriptions include: Standard Switch Operation; the auto-retract system that closes the awning automatically in windy conditions; and, the RF remote.

⚠ WARNING Awnings are designed to provide shade and protection from the sun. The effects of wind and rain on an awning are unpredictable and can cause severe damage to the awning and/or the vehicle. If wind or extended periods of rain are expected, roll up the awning.

NOTICE It is recommended that if leaving the RV unattended for a length of time, retract the awning to avoid unexpected climate conditions.

⚠ WARNING Keep all sources of heat and flame away from the awning canopy. Fabric is not fire-proof and can burn if left in contact with any flame or heat source.

NOTICE If installed, LED lighting must be turned off when the awning is in the rolled up position. This is to prevent possible damage to the LEDs and/or canopy.

Special Note: This manual provides a basic description of the product and the standard operating controls provided by Carefree of Colorado. Some Original Equipment Manufacturers (OEM's) may alter or change the placement, style and/or functional configuration of the switches. If your controls do not match the style or description included, contact the coach manufacturer for an accurate description. OEM furnished components are not covered by the Carefree warranty.

OPERATION

The Auto-Retract System is an exciting enhancement to basic awning operation. When activated, the system will retract the awning automatically in windy conditions. Sensitivity is set at the control panel.

The system uses a sensor in the motor head to detect awning motion caused by windy conditions. The system operates by gauging the vertical motion of the awning's leading edge. When persistent motion exceeds the factory preset threshold value for 2 seconds or longer, the system will automatically retract the awning. The pushbutton controls allow the user to choose between 3 factory preset sensitivity values (threshold values).

Gust detection is incorporated into the Direct Response software. When the motion value is suddenly and sharply increased above a safe maximum value, then the 2 second persistence measure is overridden and the awning closes immediately.

⚠ WARNING The Carefree Direct Response auto-retract system is a premiere electronic auto-retract system that provides protection against adverse elements; but, no auto-retract system is a guarantee against severe or destructive weather; the effects of wind and rain on an awning are unpredictable and may cause severe damage to the awning and/or vehicle. If wind or extended periods of rain are expected, retract the awning.

⚠ WARNING The power switch must be set to OFF whenever the awning is not being operated and during transport. This acts as a safety to prevent the awning from being accidentally opened.

Operational Notes:

Awning Motor: The awning motor is equipped with a thermal protection circuit to protect the motor from overheating. Operating the awning repeatedly over a short time period may cause the circuit to sense a overheat condition and shut off the motor. If this occurs, wait approximately 15 minutes to allow the motor to cool then operate the awning in normal fashion.

Ignition Lockout Sensors (Available with Direct Response Only): If the optional Carefree EL ignition lockout is installed the system will disable the extend function while the vehicle ignition key is in the ON position. Special order RTL ignition lockouts will fully retract the awning and disable the extend function when the vehicle ignition key is in the ON position. Functions will return to normal operation when the ignition key is turned OFF.

RV manufacturers may install their own lockout design. Refer to the RV literature for 12V power used for accessories.

DESCRIPTION OF CONTROLS

The Eclipse Awning with Direct Response uses 3 switches at the control panel. Power Switch; Patio Switch and Sensitivity Switch



E0043a

POWER SWITCH

POWER ONThe bottom position activates the Patio switch and the Auto-Retract system and provides power to the awning.

POWER OFFThe top position shuts the system down. The awning cannot be extended or retracted in this mode. The auto-retract system is also disabled.

IMPORTANT NOTE: The auto-retract system is ON when the power is ON. The system is OFF when the power switch is set to OFF. If the power is shut off while the awning is extended, the awning is not protected by the auto-retract system.

PATIO SWITCH

This is a two position momentary contact switch. This description also applies to any additional patio switches that may be installed.

EXTENDPress and release the switch. The awning automatically opens. To stop the awning before it is fully open, press and release the extend switch a second time.

RETRACTPress and release the switch. The awning automatically retracts until it is fully closed. To stop the awning before it is closed, press and release the retract switch a second time.

MOTION SWITCH

HIGH ↔ MED ↔ LOW

Low requires the less amount of motion before the closing the awning automatically. High requires more motion before the system closes automatically.

You may have to experiment to find the best setting for your preferences.

NOTE: If the motion switch is not installed, the system defaults to the medium setting.

OPERATING THE CONTROLS

- Turn the Power switch ON.
- Use the Patio switch to extend or retract the awning as desired.
- Set the Sensitivity switch to the level desired.

TESTING THE DIRECT RESPONSE SYSTEM

It is important to test the Direct Response system periodically to ensure that the system is working properly. Follow the simple test below.

1. Extend the awning completely.
2. Turn the mode switch to Auto-Retract ON. Set the sensitivity to the lowest setting.
3. Gently move the roller tube up and down in a vertical motion.
4. If the awning retracts, the system is working properly.
5. If the awning does not retract, contact an authorized Carefree dealer for repairs. Operate the awning with the Patio switch until the system is repaired.

USING THE KEY FOB REMOTE CONTROL

An remote control Key FOB is available only with the auto-retract systems. To use: turn system power ON. The remote provides the advantage of allowing you to operate the awning from any convenient location.

The remote has a maximum operating range of 50 feet. Actual distance may vary depending on the specific installation and location of the receiver in the vehicle.

To use: turn system power ON at the control panel.

NOTE: Power ON/OFF and the Auto-Retract sensitivity and can only be operated at the control panel.

Extend__ Press and release. The awning will extend out to the full extension and stop automatically.

Retract__ Press and release. The awning will retract and stop automatically when the awning is fully retracted.

Stop..... Press and release. During extend and retract functions, the awning may be stopped by pressing this button.



KEY FOB BATTERIES

The Key FOB w/ antenna uses a battery (Radio Shack p/n 23-279 or equivalent) that should provide a long period of service. To access: Remove the small screw from the back of the case and carefully snap off the back. Lift the old battery out and insert the new battery.

Batteries are available through your local battery outlets.

Battery life is dependent on frequency of use, environmental conditions and condition of remote.

PROGRAMMING THE REMOTE RECEIVER

When adding or replacing a remote control, it is necessary to program the transmitter and receiver.

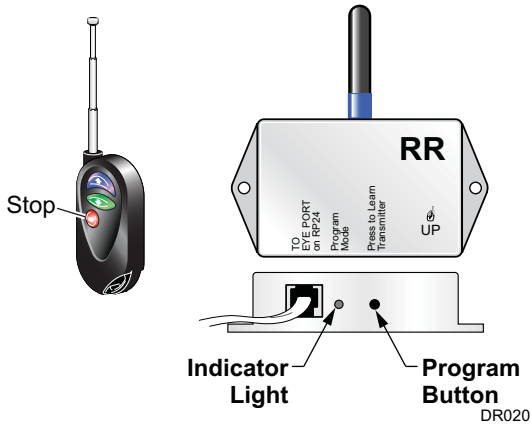

1. Power to the control box must be on.
2. Locate the receiver box.
3. Press and release the “Press to Learn Transmitter” button on the bottom of the receiver. The receiver is in program mode when the red light comes on.
4. Press and release the STOP button on the remote. The red light will go out after the receiver learns the remote signal.

NOTE: Pressing the stop button will cause the blue up arrow button to default as the close (retract) function.

If a function button is pressed to train the receiver, it will be programmed as the close (retract) button. Example: Pressing the bottom button will program the bottom button for retract and the top button as extend.

OPERATIONAL NOTES:

- The transmitter and receiver operate on a frequency of 433MHz.
- The receiver exits the program mode after ten seconds.
- If the light does not come on in step 2, the memory is full and must be cleared.
- If the light does not go out above, the receiver knows the transmitter signal or the battery in the Remote needs to be replaced.
- To clear the memory: PRESS AND HOLD the receiver learn button for 5 seconds. While holding the button, the indicator light should be OFF for the full 5 seconds then come on.
- The receiver may be programmed for up to 5 remotes. Additional remotes may be ordered separately.

ADJUSTING THE PITCH

The Eclipse arms have 6 pitch adjustment settings from minimum pitch to maximum pitch. The awning can be extended and retracted in any of these positions without having to reset the pitch between uses. See the NOTICES at the bottom of the page.

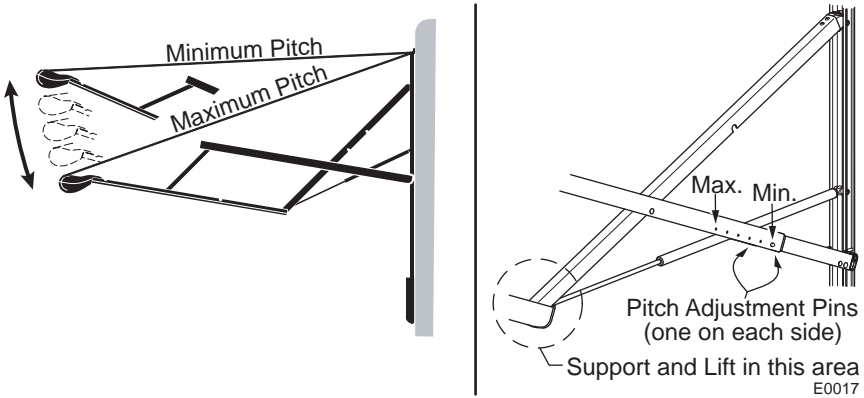

CAUTION Use care when adjusting the pitch as the awning may move abruptly.

1. Extend the awning completely. It is easier to adjust the pitch when the awning is fully extended.
2. Hold on to the awning arm to keep it steady while adjusting the pitch.
3. Press in the pitch adjustment pins, located on the long scissor arms.

Tip: Applying LIGHT pressure on the arm will decrease the force required to press the pitch adjustment pins.

4. Slide the outer scissor arm to the desired set of holes—towards the coach for a lower pitch and away from the coach for a higher pitch.

NOTICE For awnings under 12 feet long: Do not set the individual arm pitch at more than three (3) positions different between the left and right arm. Damage to the arms and canopy can occur if the awning is retracted when the arms are set at more than 3 positions difference.

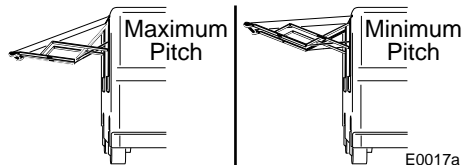
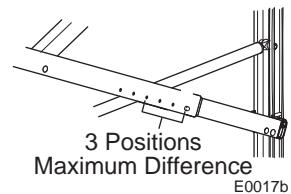

EMERGENCY OPERATION

If the original power source fails or is unavailable, the Eclipse has emergency override terminals (12V). The terminals can be used with a 9V-18V power source, such as a cordless drill battery or car battery.

WARNING Do not connect the terminals to a 110V power source!
Doing so will permanently damage the awning!

CAUTION Do not use the emergency terminals without following the directions below. The electronic circuit creates a dynamic brake for the motor by shorting and grounding the motor leads. Steps 1 & 2 remove the brake to allow the emergency override to work.

1. If there is an external plug, disconnect the plug, then go to step 3.
2. Awnings without an external plug:
 - 2.1 Remove the front cover from the motor head. There are six (6) small screws, do not remove the larger screw toward the center.
 - 2.2 Disconnect the input cable wires from the terminals. DO NOT disconnect the wires to the motor.
 - 2.3 Leave the wires disconnected and reattach the front cover.
3. Attach the provided jumper leads to the terminals, located on the rear of the motorized head.
4. Connect the other ends of the jumper leads to a 12V source. If the awning does not begin to move, reverse the leads.
5. Maintain contact throughout the retraction process.

CAUTION Use care when retracting the awning as it may move abruptly.

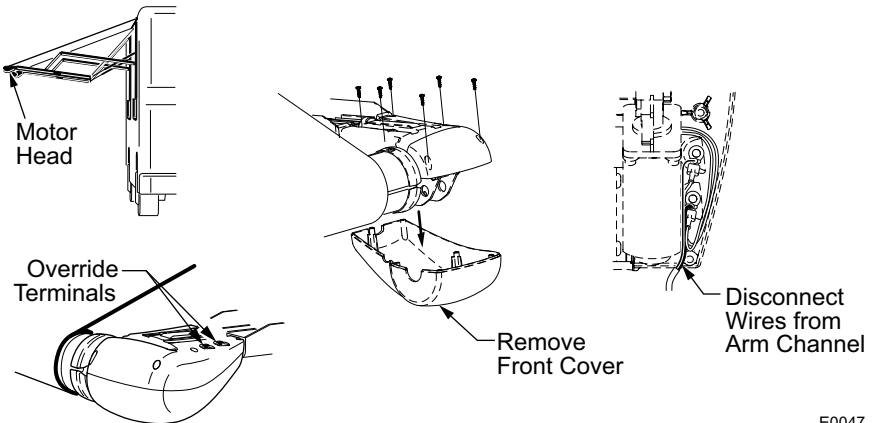

AWNING CARE

Maintaining a Carefree Awning is easy. Just follow these basic steps:

- Always operate the awning according to the instructions.
- Periodically check that the fasteners are tight. Tighten if necessary.
- Keep the awning fabric and arms clean.

FABRIC CARE

NOTICE Do not use oil based cleaners or any caustic, granulated, or abrasive type cleaners on your Carefree product.

1. One of the best ways to keep the fabric looking good and to delay the need for deep or vigorous cleanings is to hose fabrics off on a monthly basis with clear water. This practice will help prevent dirt from becoming deeply imbedded in the fabric. In most environments, a thorough cleaning will be needed every two to three years.
2. When it's time for a thorough cleaning, the fabric can be cleaned while still on the awning frame.
 - For Vinyl Fabric – Use a soft brush and warm water with soap.
 - For Acrylic Fabric – Use a stiff brush and warm water with soap.
3. When cleaning the fabric, it is important to observe the following:
 - Always use a natural soap, never detergent.
 - Water should be cold to lukewarm, never more than 100°F.
 - Air-dry only. Never apply heat to the fabric.
 - Always allow the fabric to dry thoroughly before rolling up the awning.

MILDEW

Mildew is a fungus growth that looks like dirt. Vinyl coated polyester fabrics are mildew resistant because of a chemical biocide in the vinyl coating. Under ordinary conditions, mildew will not appear. However, in areas where high temperature and humidity are common, mildew can be a problem and require the material to be washed more frequently. Thoroughly rinse the fabric with clean water and allow to air dry completely before rolling up the awning.

POOLING

When water collects on the top of the fabric, this is known as "pooling". This can occur during inclement weather or if a running air conditioner discharges over the awning. The water is dumped when the awning is retracted. It is recommended that if water accumulates on the top; retract the awning in steps (8"-12") to dump the water. This will help prevent the fabric from stretching or distorting.

ARM CARE

The best method of keeping the arms operating smoothly is to clean them. Dirt and debris can cause the channels not to slide easily. **Avoid introducing water into the motorized and non-motorized housings.**

Periodically wash out the channels with running water (i.e. a hose) to keep them clean. If the arms still do not slide easily, lightly spray the pivot and contact points with a dry silicone lubricant after the arms have been cleaned and dried thoroughly.