

ULTRA SILENT™ FAN - HANGER BAR KIT

For use with Broan or NuTone QT Fans & Fan Lights

TYPICAL INSTALLATIONS

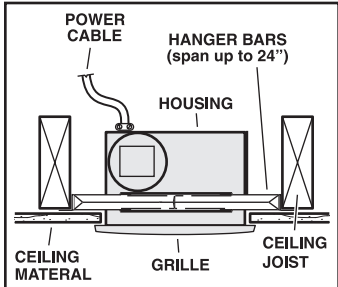

Housing mounted anywhere between joists using hanger bars.

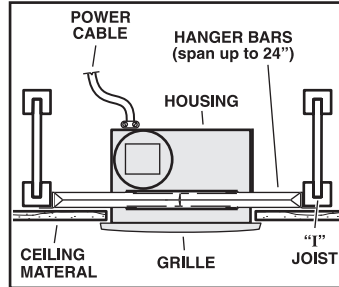

Housing mounted anywhere between I-joists using hanger bars.

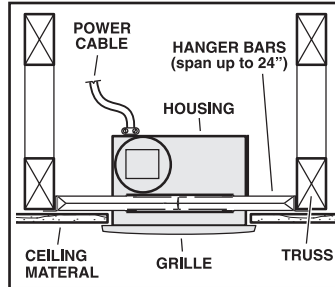

Housing mounted anywhere between trusses using hanger bars.

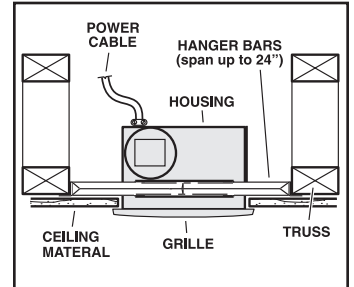

Housing mounted anywhere between trusses using hanger bars.

THIS KIT INCLUDES:

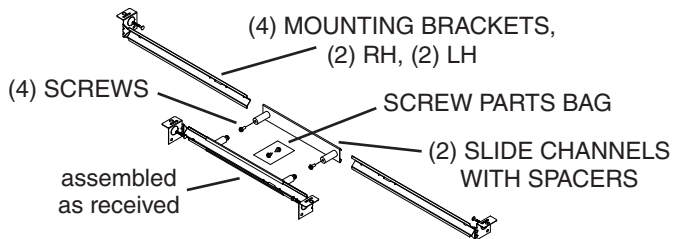

TOOLS NEEDED



INSTALLATION

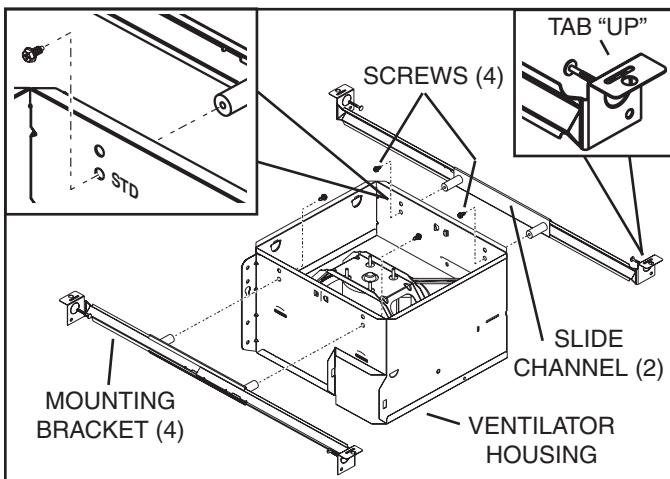

1. Assemble slide channels and mounting brackets to ventilator housing.

Attach the SLIDE CHANNELS to the housing using the SCREWS supplied. Make sure TABS face "up" as shown. Use the set of channel mounting holes (marked "STD") to mount the housing flush with the bottom of the drywall. Use the other set of holes (not marked) to mount the housing flush with the top of the drywall.

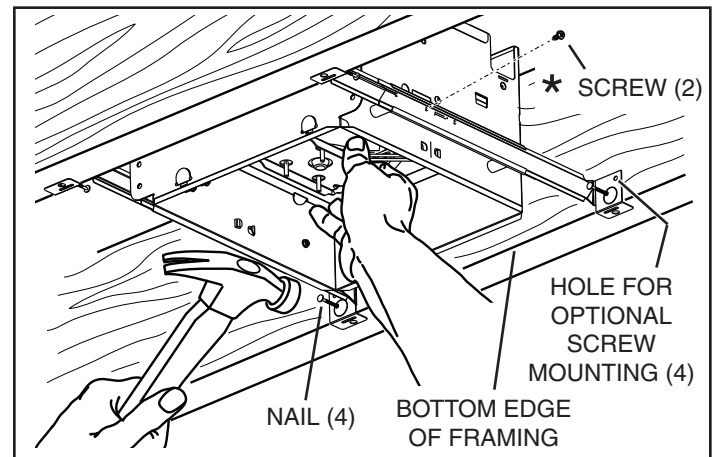

2. Fasten ventilator to framing.

Extend mounting brackets to the width of the framing.

Hold ventilator in place with the mounting brackets wrapping around the bottom edge of the framing.

Nail ventilator to framing or fasten with screws (not provided) through holes near nails.

* To ensure a noise-free mount: Secure mounting brackets together with screws or use a pliers to crimp slide channels tightly around mounting brackets.

Connect ductwork, wiring, and finish installation following instructions supplied with the fan or fan/light.