

# MODEL QK60

## QuicKit™

# BATH FAN UPGRADE KIT

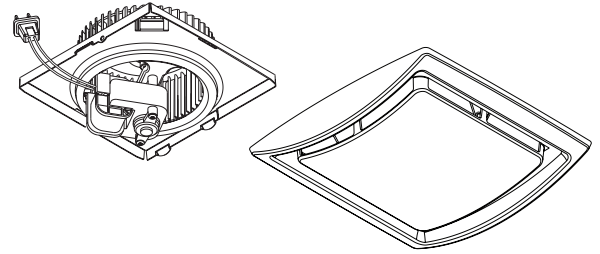

Reduces the sound level of your existing bath fan by up to 35%, with an up to 68% higher sound quality rating.\* Increases air movement by up to 45%.\* No rewiring or new ductwork required.

### FEATURES

#### GRILLE:

- Brighter white - blends well with any decor
- Torsion spring grille mounting - no tools required

#### BLOWER ASSEMBLY:

- Plug-in, permanently lubricated motor
- Polymeric blower wheel
- Galvanized steel motor plate
- Fits into your existing bath fan housing

### SPECIFICATIONS

VOLTS	AMPS	CFM	SONES
120	1.2	60	2.5

The kit will work with these fan models if the fan housing measures 7½" x 7¼":



**NuTone 695, 696N**



**Nautilus N671, N688**



**Broan 670, 671, 688, 689**

\* Installed performance compared to typical existing fans.

### TYPICAL SPECIFICATION

Bath Fan Upgrade Kit shall be Broan Model QK60.

Bath Fan Upgrade Kit shall include a galvanized steel motor plate designed to accommodate a variety of economy fan models.

Motor shall be permanently lubricated.

Air delivery shall be no less than 60 cfm and sound level no greater than 2.5 Sones. All air and sound ratings shall be certified by HVI. Unit shall be U.L. Listed.

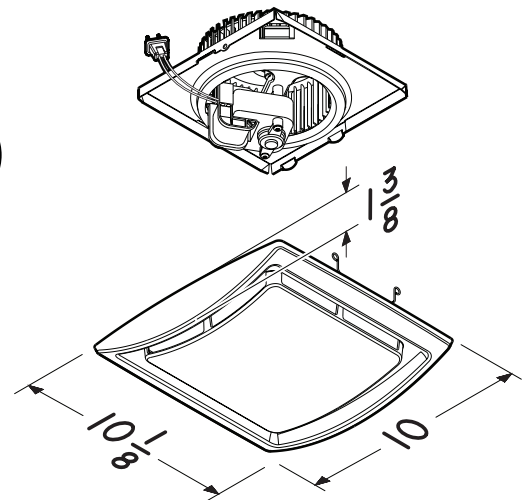

HVI-2100 CERTIFIED RATINGS comply with new testing technologies and procedures prescribed by the Home Ventilating Institute, for off-the-shelf products, as they are available to consumers. Product performance is rated at 0.1 in. static pressure, based on tests conducted in a state-of-the-art test laboratory. Sones are a measure of humanly-perceived loudness, based on laboratory measurements.