

## PUREPOWER SERIES PP5501

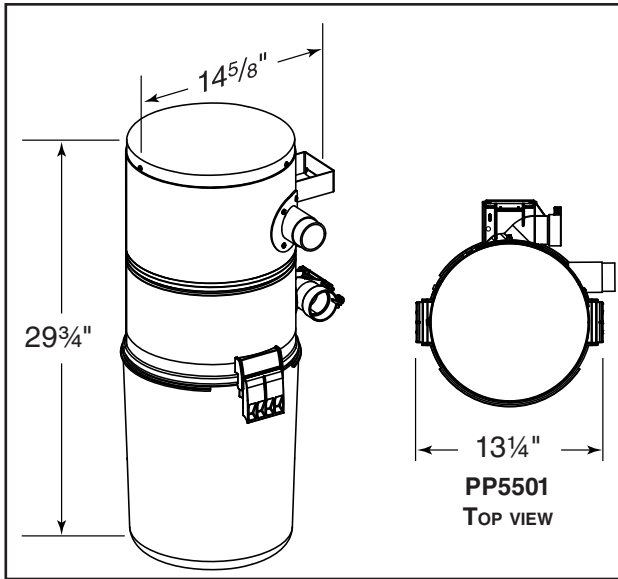

### SPECIFICATIONS

Motor	1-Stage
Horsepower	2.1 @ Full open orifice
Amperes	12
Voltage	120 VAC
Water Lift	120"
Air Watts	550
Switch on Power Unit	Yes
Recommended Circuit	Minimum 20 Amps
Filtration Type	Disposable bag
Capacity	6 U.S. Gallons
Filtration Level	Standard
Quietness	66 dB
UL Listed	Yes
Housing	Metal housing with polymeric debris pail
Dimensions	13 1/4" W x 14 5/8" D x 29 3/4" H

Designed for homes from 1,000 to 4,000 ft.<sup>2</sup>, this power unit features a 1-stage motor that delivers 550 air watts of power.

### FEATURES

- Standard filtration for clean indoor air
- Quiet operation; no muffler required
- Large 6 U.S. gallon disposable bag that typically needs emptying only every 6 months
- Oversized debris pail handles made for a quick and easy pail removal
- Wall-mount bracket for simple, safe and secure mounting
- Six foot long power cord
- UL Listed
- 5-Year parts warranty and 3-Year labor warranty

