

READ AND SAVE THESE INSTRUCTIONS

WARNING

TO REDUCE THE RISK OF FIRE, ELECTRIC SHOCK, OR INJURY TO PERSONS, OBSERVE THE FOLLOWING:

1. Use this unit only in the manner intended by the manufacturer. If you have questions, contact the manufacturer at the address or telephone number listed in the warranty.
2. Before servicing or cleaning unit, switch power off at service panel and lock the service disconnecting means to prevent power from being switched on accidentally. When the service disconnecting means cannot be locked, securely fasten a prominent warning device, such as a tag, to the service panel.
3. Installation work and electrical wiring must be done by a qualified person(s) in accordance with all applicable codes and standards, including fire-rated construction codes and standards.
4. Sufficient air is needed for proper combustion and exhausting of gases through the flue (chimney) of fuel burning equipment to prevent backdrafting. Follow the heating equipment manufacturer's guideline and safety standards such as those published by the National Fire Protection Association (NFPA), and the American Society for Heating, Refrigeration and Air Conditioning Engineers (ASHRAE), and the local code authorities.
5. When cutting or drilling into wall or ceiling, do not damage electrical wiring and other hidden utilities.
6. Ducted fans must always be vented to the outdoors.
7. To reduce the risk of fire, use only metal ductwork.
8. Models L100, L150, L200, L250, and L300 only:
If this unit is to be installed over a tub or shower, it must be marked as appropriate for the application and be connected to a GFCI (Ground Fault Interrupter) - protected branch circuit.
9. Never place a switch where it can be reached from a tub or shower.
10. This unit must be grounded.

CAUTION

1. For general ventilating use only. Do not use to exhaust hazardous or explosive materials and vapors.
2. To avoid motor bearing damage and noisy and/or unbalanced impellers, keep drywall spray, construction dust, etc. off power unit.
3. Please read specification label on product for further information and requirements.

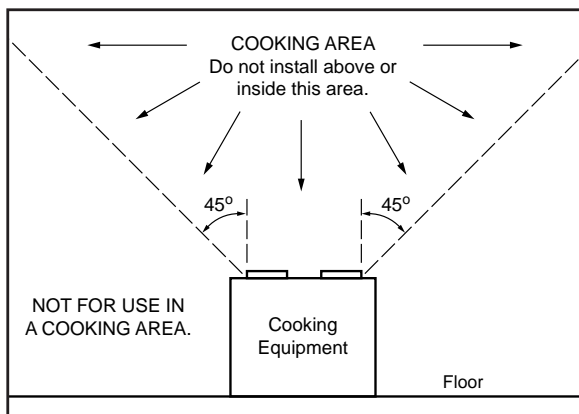

TYPICAL INSTALLATION

MOUNTING (New Frame Construction)

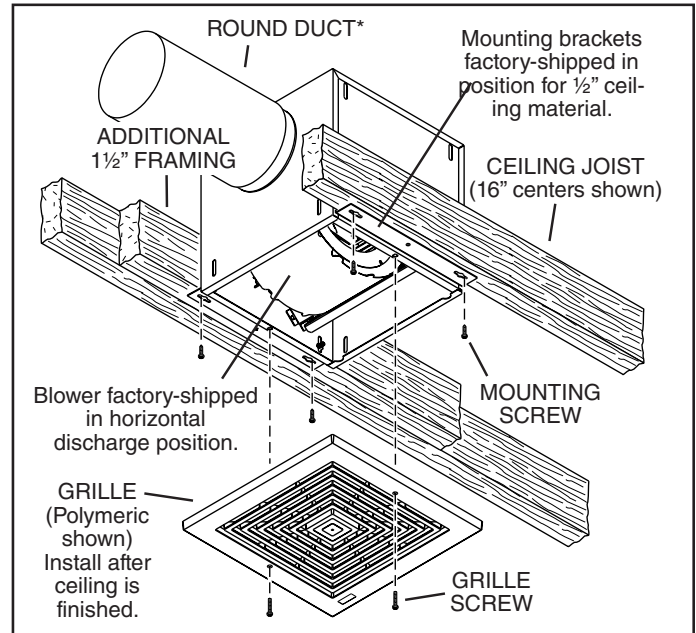

Factory-shipped unit installed in new construction.

MOUNTING (Existing Frame Construction)

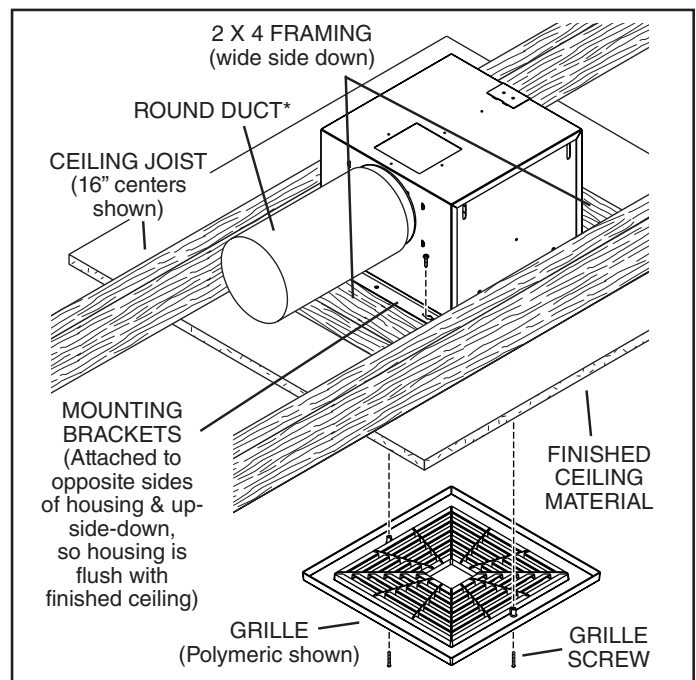

Factory-shipped unit installed in existing construction.

* L100 & L150 Series uses 6" Round Duct.
L200, L250, & L300 Series uses 8" Round Duct.

TYPICAL INSTALLATION

WIRING

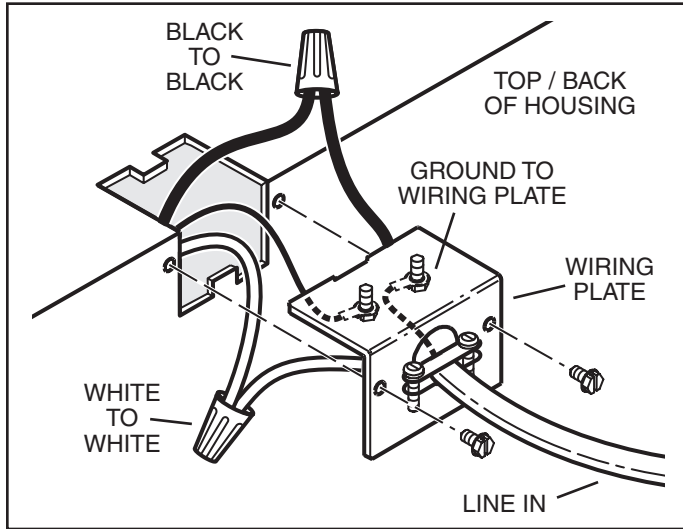

Ventilator can be wired from outside of housing. Use UL approved connectors to wire per local codes.

DUCTING (Horizontal blower discharge)

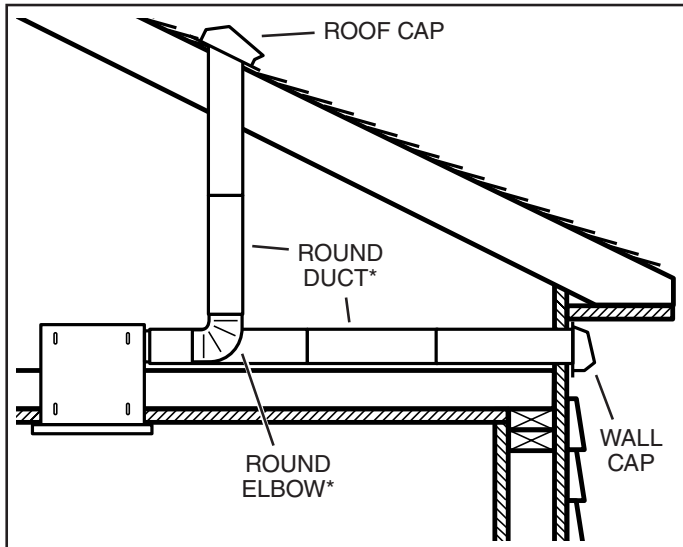

Two ways to connect ductwork to a factory-shipped unit.

* L100 & L150 Series uses 6" Round Duct.
L200, L250, & L300 Series uses 8" Round Duct.

IMPORTANT:

Remove shipping tape from damper

Remove the shipping tape from the damper flap and make sure that damper flap opens and closes freely inside the ductwork. Use duct tape to make ductwork connections secure and air-tight.

Remove shipping ring from blower inlet

Remove the shipping ring from the blower inlet before operating the ventilator.

MOUNTING OPTIONS

1/4-20 hex nuts secure mounting brackets to housing. Loosen and re-tighten or remove and replace nuts as necessary for desired mounting bracket position.

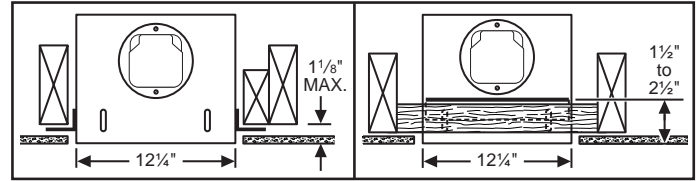

Mounting brackets in factory-shipped position. (Outlet parallel to joists.) (New construction)

Mounting brackets flipped over and mounted to outlet sides of housing. (Outlet parallel to joists.) (Existing construction)

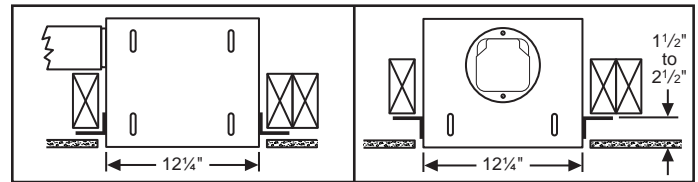

Mounting brackets mounted to outlet sides of housing. (Outlet perpendicular to joists.) (New construction)

Mounting brackets flipped over to give approx. 1" more clearance. (Outlet parallel to joists.) (New construction)

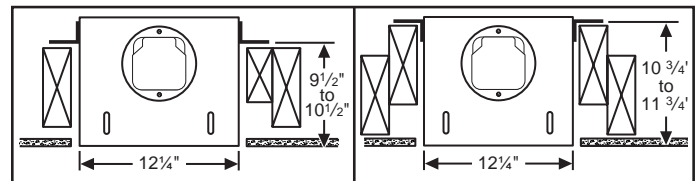

Mounting brackets mounted to top of sides of housing. (Outlet parallel to joists.) (New or existing construction)

Mounting brackets flipped over and mounted to top of sides of housing. (Outlet parallel to joists.) (New or existing construction)

WIRING OPTIONS

WIRING PLATE POSITION

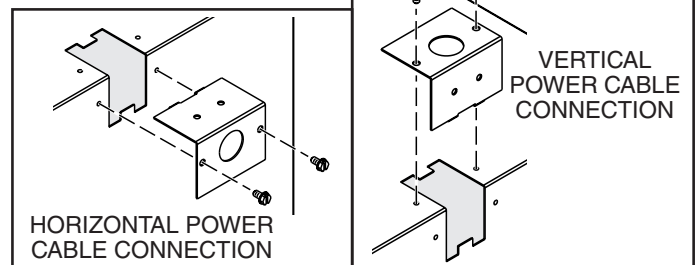

HORIZONTAL POWER CABLE CONNECTION

VERTICAL POWER CABLE CONNECTION

Wiring plate mounts to side or top of housing.

DUCTING OPTIONS

BLOWER DISCHARGE POSITIONS

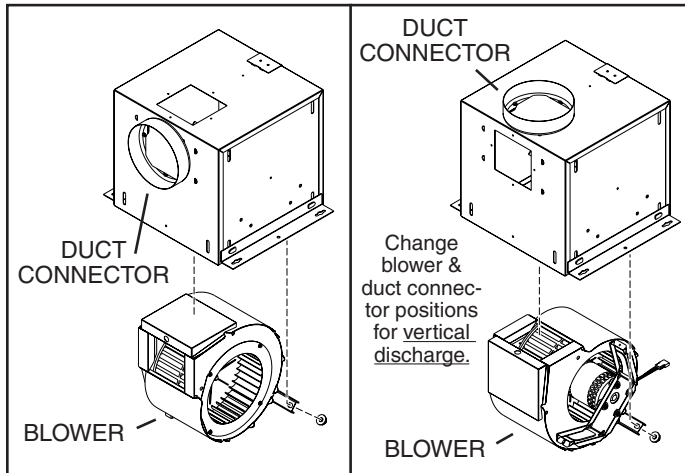

Blower and duct connector in horizontal discharge position. (Factory shipped)

Blower and duct connector in vertical discharge position.

DUCTING (Vertical blower discharge)

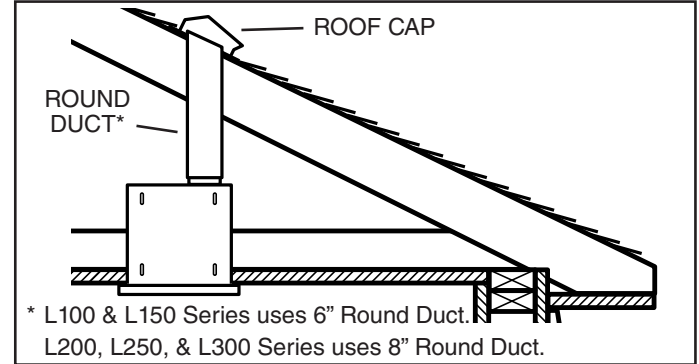

Typical ductwork connection to a ventilator converted to vertical discharge.

USE AND CARE

Ventilator is designed for continuous operation. If desired, it may be controlled using an on/off switch or a solid-state, variable speed control. Follow wiring instructions packed with control, and adhere to all local and state codes, and the National Electrical Code.



WARNING: To reduce the risk of electric shock, disconnect from power supply before servicing.

To clean grille: Use appropriate vacuum attachment or remove grille and clean with a soft cloth and mild soap or detergent. Dry grille thoroughly before reinstalling.

To clean blower assembly: Remove grille, unplug blower from housing, remove blower mounting nuts, and carefully remove blower from housing. Use appropriate vacuum attachment or a soft cloth and mild soap or detergent to clean blower discharge area and wheel. **DO NOT ALLOW WATER TO ENTER MOTOR.** Make sure blower assembly is completely dry before reinstalling.

Motor is permanently lubricated. Do not oil or disassemble motor.