

BROAN®

INSTALLATION GUIDE

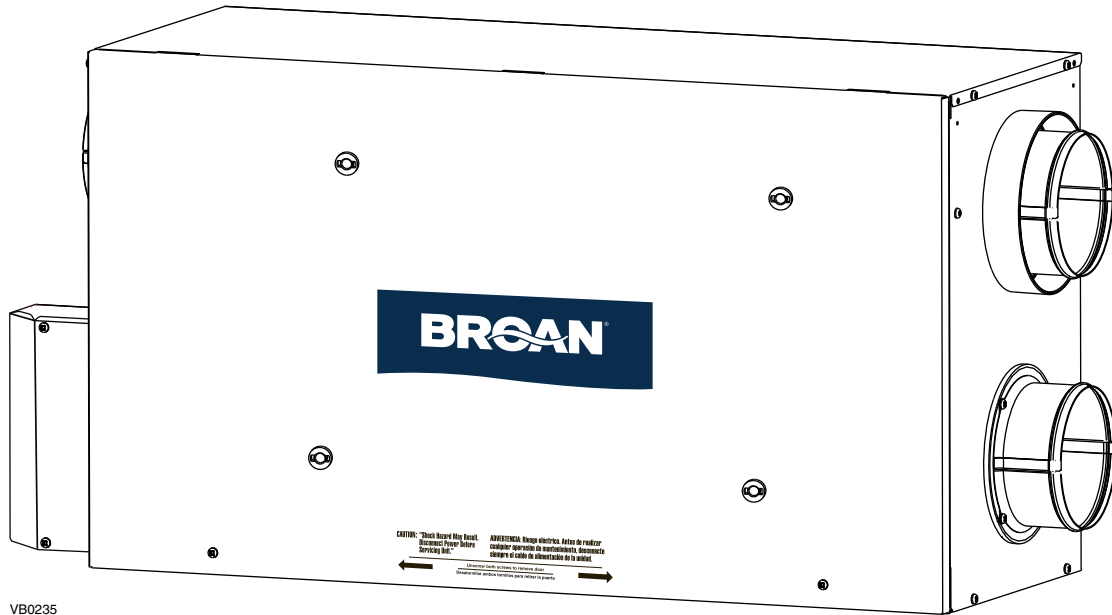

MODELS HRVH100S AND ERVH100S



These products earned the ENERGY STAR® by meeting strict energy efficiency guidelines set by Natural Resources Canada and the US EPA. They meet ENERGY STAR requirements only when used in Canada.

⚠ RESIDENTIAL INDOOR USE ONLY ⚠

READ AND SAVE THESE INSTRUCTIONS

ABOUT THIS GUIDE

Please take note that this manual uses the following symbols to emphasize particular information:

⚠ WARNING

Identifies an instruction which, if not followed, might cause serious personal injuries including possibility of death.

CAUTION

Identifies an instruction which, if not followed, may severely damage the unit and/or its components.

NOTE: Indicates supplementary information needed to fully complete an instruction.

ABOUT THESE UNITS

LIMITATION

For residential (domestic) installation only. Installation work and electrical wiring must be done by a qualified person(s) in accordance with all applicable codes and standards, including fire-rated construction codes and standards.

⚠ WARNING

TO REDUCE THE RISK OF FIRE, ELECTRIC SHOCK, OR INJURY TO PERSON(S) OBSERVE THE FOLLOWING:

1. Use this unit only in the manner intended by the manufacturer. If you have questions, contact the manufacturer at the address or telephone number listed in the warranty.
2. We recommend that your unit be inspected by a specialized technician once a year.
3. Before servicing or cleaning the unit, disconnect power cord from electrical outlet.
4. This unit is not designed to provide combustion and/or dilution air for fuel-burning appliances.
5. When cutting or drilling into wall or ceiling, do not damage electrical wiring and other hidden utilities.
6. Do not use this unit with any solid-state speed control device other than following optional main and auxiliary wall controls:

Optional Main Controls	Optional Auxiliary Controls
VT8W, VT7W, VT4W and VT6W	59W and VB60W

7. This unit must be grounded. The power supply cord has a 3-prong grounding plug for your personal safety. It must be plugged into a mating 3-prong grounding receptacle, grounded in accordance with the national electrical code and local codes and ordinances. Do not remove the ground prong. Do not use an extension cord.
8. Do not install in a cooking area or connect directly to any appliances.
9. Do not use to exhaust hazardous or explosive materials and vapors.
10. When performing installation, servicing or cleaning the unit, it is recommended to wear safety glasses and gloves.
11. Due to the weight of the unit, two installers are recommended to perform installation.
12. When applicable local regulations comprise more restrictive installation and/or certification requirements, the aforementioned requirements prevail on those of this document and the installer agrees to conform to these at his own expenses.

CAUTION

1. To avoid premature clogged filters, turn OFF the unit during construction or renovation.
2. Please read specification label on product for further information and requirements.
3. Be sure to duct air outdoor – Do not intake/exhaust air into spaces within walls or ceiling or into attics, crawl spaces, or garage.
4. Intended for residential installation only in accordance with the requirements of NFPA 90B.
5. Do not run any air ducts directly above or closer than 2 ft to any furnace or its supply plenum, boiler, or other heat producing appliance. If a duct has to be connected to the furnace return plenum, it must be connected not closer than 9' 10" from this plenum connection to the furnace.
6. The ductwork is intended to be installed in compliance with all applicable codes.
7. When leaving the house for a long period of time (more than two weeks), a responsible person should regularly check if the unit operates adequately.
8. If the ductwork passes through an unconditioned space (e.g.: attic), the unit must operate continuously except when performing maintenance and/or repair. Also, the ambient temperature of the house should never drop below 65°F.

TABLE OF CONTENTS

1.	DIMENSIONS	3
2.	TYPICAL INSTALLATIONS.	4
2.1	FULLY DUCTED SYSTEM	4
2.2	CENTRAL DRAW POINT	4
2.3	SIMPLIFIED INSTALLATION	4
3.	INSTALLATION	5-11
3.1	INSPECT THE CONTENT OF THE BOX	5
3.2	TOOLS AND MATERIAL	6
3.3	LOCATING THE UNIT	6
3.4	PLANNING OF THE DUCTWORK	6
3.5	INSTALLING NON-INSULATED DUCTS AND DIFFUSERS	7-9
3.5.1	FULLY DUCTED SYSTEM	7
3.5.2	CENTRAL DRAW POINT	8
3.5.3	SIMPLIFIED INSTALLATION.	9
3.6	INSTALLING INSULATED FLEXIBLE DUCTS	10
3.6.1	CONNECTION TO THE UNIT PORTS	10
3.6.2	LOCATING EXTERIOR PORTS	10
3.7	CONNECTING INSULATED DUCTS TO EXTERIOR PORTS	11
3.8	INSTALLING TANDEM® TRANSITION KIT	11
3.9	CONNECTING THE DRAIN	11
4.	CONTROLS	12-14
4.1	INTEGRATED CONTROL	12
4.2	BOOTING SEQUENCE	12
4.3	SETTING EXTENDED DEFROST	12
4.4	ELECTRICAL CONNECTION TO OPTIONAL WALL CONTROLS	13-14
4.4.1	ELECTRICAL CONNECTION TO VT8W MAIN WALL CONTROL.	13
4.4.2	ELECTRICAL CONNECTION TO VT7W MAIN WALL CONTROL.	13
4.4.3	ELECTRICAL CONNECTION TO VT4W MAIN WALL CONTROL.	13
4.4.4	ELECTRICAL CONNECTION TO VT6W MAIN WALL CONTROL.	13
4.4.5	ELECTRICAL CONNECTION TO OPTIONAL AUXILIARY WALL CONTROLS.	14
5.	ELECTRICAL CONNECTION TO THE FURNACE	15
6.	WIRING DIAGRAM	16
7.	BALANCING THE UNIT.	17
8.	SERVICE PARTS	18
9.	TROUBLESHOOTING	19-20

1. DIMENSIONS

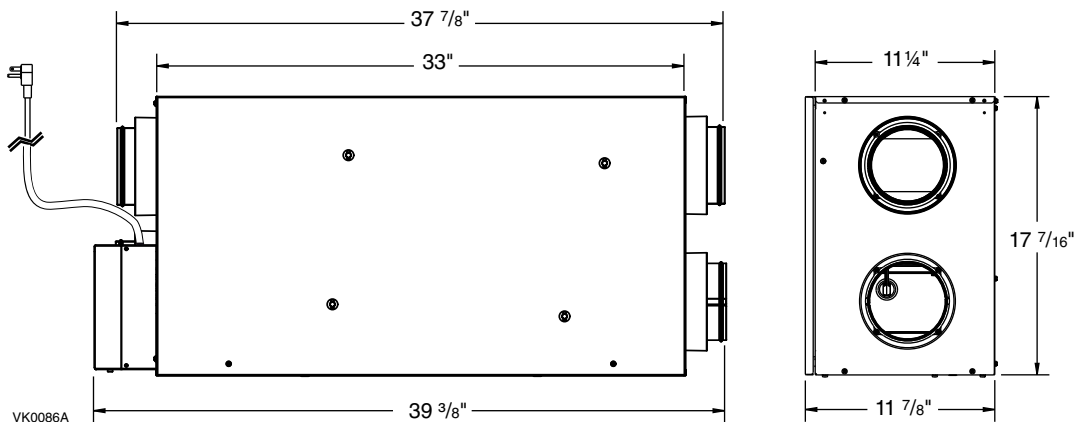

2. TYPICAL INSTALLATIONS

Use the following illustrations as guidelines to help you decide on how the unit will be installed.

All the units should be hung from the joists.

In every case, bathroom fans and a range hood could be used to exhaust stale air. Also, for homes with more than one level, we recommend one exhaust register at the highest level.

There are 3 installation methods: Fully Ducted System, Central Draw Point and Simplified Installation.

NOTE: An electrical outlet has to be available within 3 feet of the unit.

2.1 FULLY DUCTED SYSTEM (PRIMARYLY FOR HOMES WITH RADIANT HOT WATER OR ELECTRIC BASEBOARD HEATING)

Stale air coming from the register located at the highest level of the house is exhausted to the outdoor. Fresh air from outdoor is filtered and supplied by the register located in the lowest liveable level.

Homes with more than one level require at least one exhaust register at the highest level.

See figure at right.

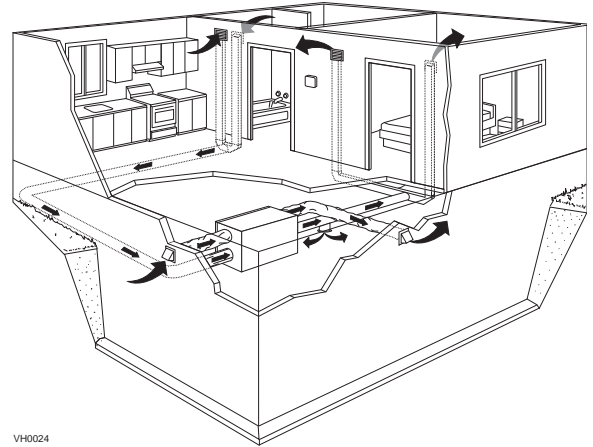

2.2 CENTRAL DRAW POINT (CONNECTION TO A FORCED AIR SYSTEM)

Stale air coming from the register located at the highest level of the house is exhausted to the outdoor. Fresh air from outdoor is filtered and supplied to the return (plenum) or the supply duct of the forced air unit. See figure at right.

For this type of installation, it is not essential that the forced air system blower runs when the unit is in operation, but we recommend it.

NOTE: Home with multiple forced air systems should have one unit on each system.

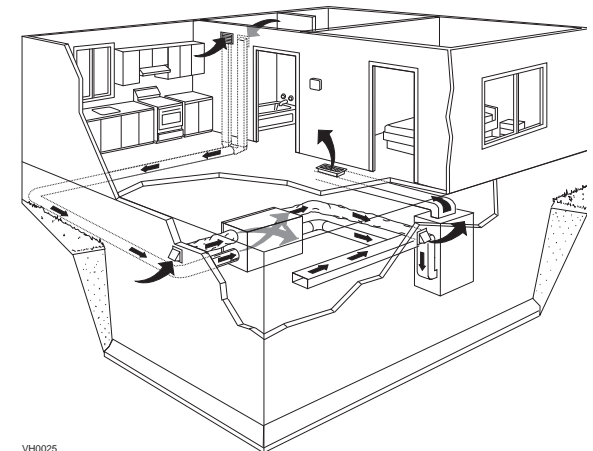

2.3 SIMPLIFIED INSTALLATION (CONNECTION TO A FORCED AIR SYSTEM)

Stale air is exhausted to the outdoor. Fresh air from outdoor is filtered and supplied to the return (plenum) or the supply duct of the forced air unit.

See figure at right.

To avoid cross-contamination and achieve the highest efficiencies, the forced air system blower must always be ON.

NOTE: Home with multiple forced air systems should have one unit on each system.

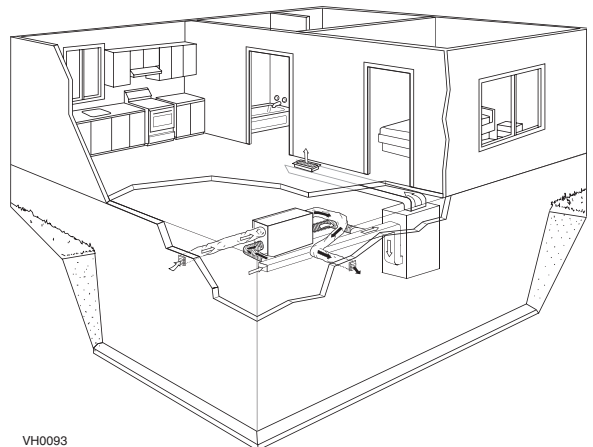

3. INSTALLATION

3.1 INSPECT THE CONTENT OF THE BOX

NOTE: Before proceeding to the installation, check the content of the box. Remove all packaging material from the unit.

- Inspect the exterior of the unit for shipping damage. Ensure that there is no damage to the door, ports, power cord, etc.

- Using a Phillips or a Robertson screwdriver, loosen both door screws (A).
NOTE: The screws will stay attached to the door.

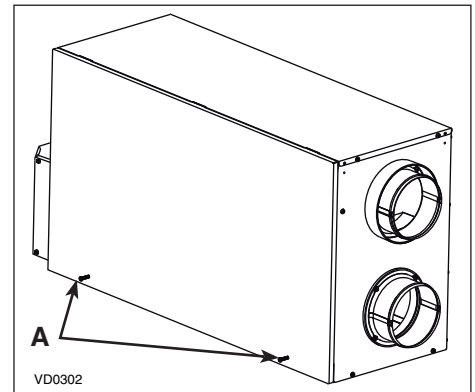

- Open (B) and lift out (C) the door.

CAUTION
In order to prevent damages to the door hooks, do not open completely the unit door; tilt it about 3" from the unit base and lift it up. See illustration at right.

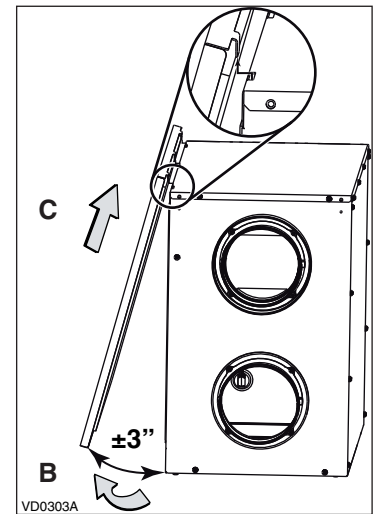

- Remove the transport tape over the heat or energy recovery core of the unit.
- Inspect the inside of the unit for damage. Ensure that blower assembly, heat or energy recovery core, core filters, insulation, dampers, prefilter and HEPA filter, etc. are all intact, then reinstall the door.

NOTE: Write the installation date on the HEPA filter frame for future reference (see illustration at right).

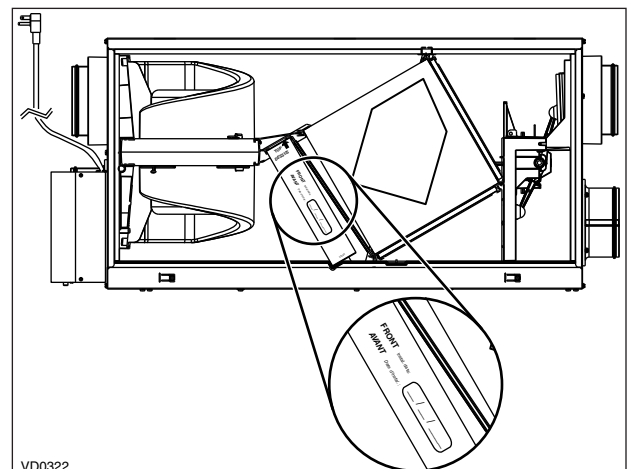

3. INSTALLATION (CONT'D)

3.2 TOOLS AND MATERIAL

Following are the tools and material needed:

- Phillips no. 2 or Robertson no. 2 screwdriver
- Small flat blade screwdriver (for wall control connection)
- Wire stripper (for wall control connection)
- Hammer and flat blade screwdriver (for plenum or supply furnace duct connection installation only, to make holes in existing metal duct)
- Scissors or utility knife (to cut duct tape)
- Measuring tape
- Duct tape
- Tin snips or metal shear (for plenum or supply furnace duct connection installation only, to cut ductwork)
- Aluminum duct tape (for plenum connection installation only)
- Jig saw
- Caulking gun and caulking.

3.3 LOCATING THE UNIT

Choose an appropriate location for the unit.

- Within an area of the house **where the ambient temperature is kept between 50°F and 104°F.**
- Away from living areas (dining room, living room, bedroom), if possible.
- So as to provide easy access to the interior of the unit, for maintenance.
- Close to an exterior wall, so as to limit the length of the insulated flexible duct to and from the unit.
- Away from hot chimneys and other fire hazards.
- Allow for a power source (standard 3-prong grounding outlet).
- FOR HRV UNITS ONLY: Close to a drain. If no drain is close by, use a pail to collect run-off.

Hang the unit with the four hooks, chains and springs provided. See illustration at right.

CAUTION
Make sure the unit is level.

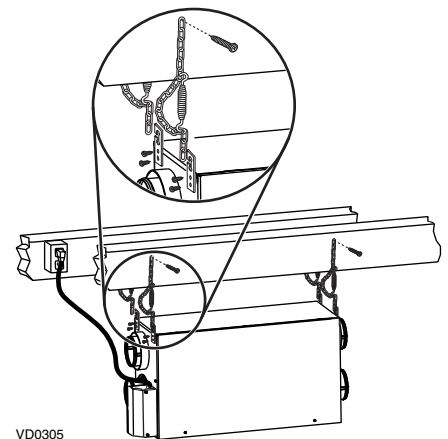

3.4 PLANNING OF THE DUCTWORK

- Keep it simple. Plan for a minimum of bends and joints.
- Keep the length of insulated ducts to a minimum.
- Do not ventilate crawl spaces or cold rooms. Do not attempt to recover the exhaust air from a dryer or a range hood. This would cause clogging of the filters and recovery module.
- If the house has two floors or more, be sure to plan for at least one exhaust register on the highest lived-in level.

3. INSTALLATION (CONT'D)

3.5 INSTALLING NON-INSULATED DUCTS AND DIFFUSERS

3.5.1 FULLY DUCTED SYSTEM (AS ILLUSTRATED IN SECTION 2.1)

⚠ WARNING

Never install a stale air exhaust diffuser in a closed room where a combustion device operates, such as a gas furnace, a gas water heater or a fireplace.

Stale air exhaust ductwork

- Install the stale air exhaust diffuser in the main area where the contaminants are produced: kitchen, living room, etc. Position the diffuser as far from the stairway as possible and in such a way that the air circulates in all the lived-in spaces in the house. If desired, you can install another diffuser (sold separately).
- If a diffuser is installed in the kitchen, it must be located at least 4 feet from the range.
- Install the diffuser 6 to 12 inches from the ceiling on an interior wall OR install it in the ceiling.

Fresh air distribution ductwork

- Install the fresh air distribution diffuser in a large, open area in the lowest level to ensure the greatest possible air circulation.
- Keep in mind that the fresh air diffuser must be located as far as possible from the stale air diffuser. If desired, you can install another diffuser.
- Install the diffuser either in the ceiling OR 6 to 12 inches from the ceiling on an interior wall. (The cooler air will then cross the upper part of the room and mix with room air, before descending to occupant's level.)
- If a register must be floor installed, direct the airflow up the wall.

HOW TO CONNECT THE FLEXIBLE DUCTS TO THE DIFFUSERS

Once the diffusers location is determined, cut out 5¼" diameter hole. Run one end of the flexible duct through the hole and fix it to the diffuser base (1), using a tie wrap and duct tape. Assemble the diffuser base to the wall (or ceiling) using its 4 no. 8 x 3/4" screws. Then, slide in the diffuser (2). See illustration at right.

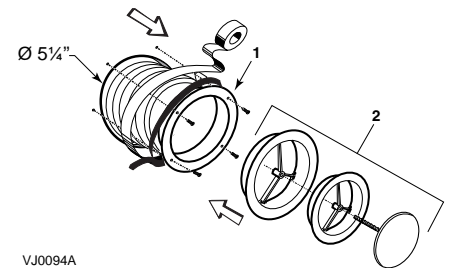

UNIT PORTS IDENTIFICATION

Each unit port has an identification label beside it to avoid wrong duct connections to the unit. Always refer to these labels before performing any duct and port connection.

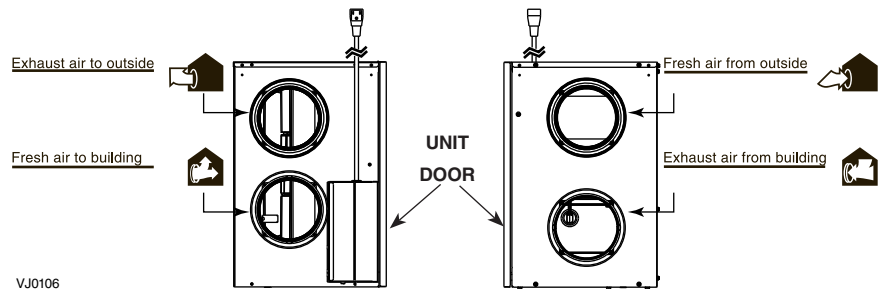

HOW TO CONNECT THE FLEXIBLE DUCTS TO THE UNIT PORTS

Both flexible ducts attached to the diffusers must be connected to the bottom ports of the unit. When facing the unit door, the fresh air to building port is located on left side and the exhaust air from building port is on the right side. Refer to the identification labels affixed beside each unit ports. Using tie wrap, attach the fresh air to building duct to its corresponding port, then do the same for the exhaust air to building duct and port. See illustration at right.

NOTE: Use an insulated duct if the duct will have to go through a space where it is possible to experience extreme temperature conditions (eg: in northern area, unheated attic in winter or uncooled attic in southern area). Also, if you plan to stop the unit for more than 12 hours, we recommend to cover the duct with R12 insulation.

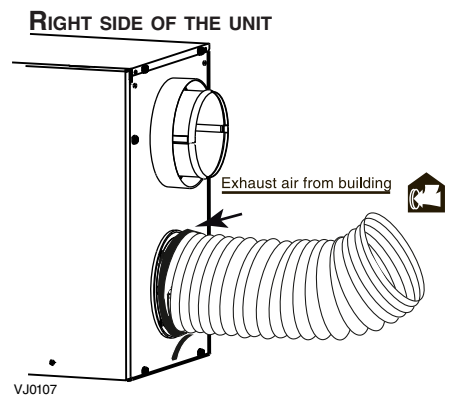

3. INSTALLATION (CONT'D)

3.5 INSTALLING NON-INSULATED DUCTS AND DIFFUSERS (CONT'D)

3.5.2 CENTRAL DRAW POINT (AS ILLUSTRATED IN SECTION 2.2)

Stale air exhaust ductwork

Same as for Fully Ducted System, described in step 3.5.1

Fresh air distribution ductwork

⚠ WARNING

When performing duct connections, always use approved tools and materials. Respect all corresponding laws and safety regulations. Please refer to your local building code.

CAUTION

When performing connection to the furnace supply duct, this duct must be sized to support the additional air flow produced by the HRV/ERV. Also, use a metal duct with a backdraft damper to prevent the risk of overheating the HRV/ERV.

There are 2 methods for connecting the unit to the furnace:

Method 1: Supply side connection

- Cut an opening into the furnace supply duct at least 18" from the furnace.
- Connect this opening to the fresh air distribution port of the HRV/ERV (use **metal duct**, see figure at right).
- Make sure that the HRV/ERV duct forms an elbow inside the furnace ductwork.
- If desired, interlock (synchronize) the furnace blower operation with the HRV/ERV operation (see Section 5).

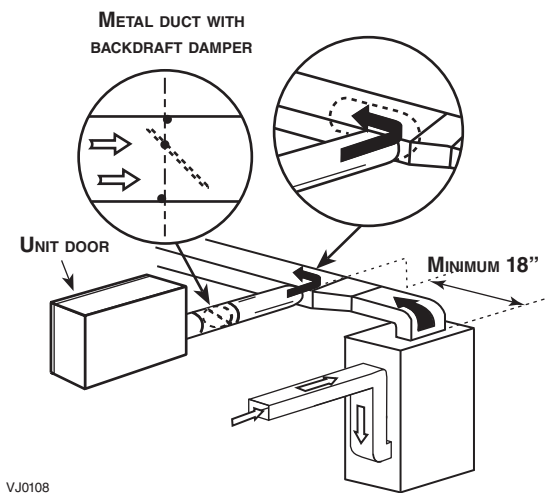

VJ0108

Method 2: Return side connection

- Locate the opening for fresh air ductwork on the forced air unit return duct at a minimum linear distance of 9' 10" upstream (from forced air unit drop: **A+B+C**). Cut out a 5" Ø hole in this location, using metal shear.
- Use a metal transition to connect the unit duct to the forced air unit return duct.
- Attach the other end of the flexible duct to the Fresh air to building port (see icon on the left side of the unit). Use tie wrap and duct tape to seal the connection. See illustration at right.

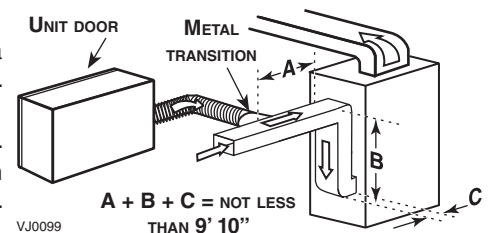

VJ0099

3. INSTALLATION (CONT'D)

3.5 INSTALLING NON-INSULATED DUCTS AND DIFFUSERS (CONT'D)

3.5.3 SIMPLIFIED INSTALLATION (AS ILLUSTRATED IN SECTION 2.3)

Fresh air distribution ductwork (return side connection)

Same as for Central Draw Point, described in step 3.5.2

Stale air exhaust ductwork (return side connection)

⚠ WARNING

When performing duct connections, always use approved tools and materials. Respect all corresponding laws and safety regulations. Please refer to your local building code.

CAUTION

When performing connection to the furnace supply duct, this duct must be sized to support the additional air flow produced by the HRV/ERV. Also, use a metal duct with a backdraft damper to prevent the risk of overheating the HRV/ERV.

There are 2 methods for connecting the unit to the furnace:

Method 1: Return-supply connection

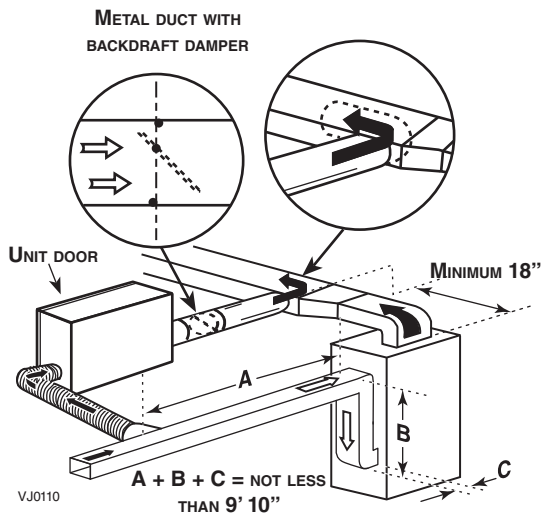

Method 2: Return-return connection

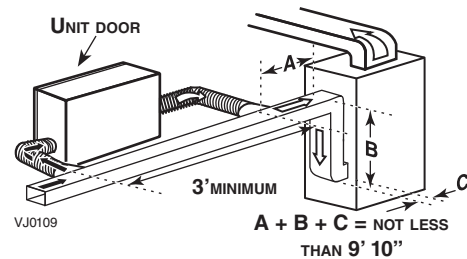

Stale air intake:

- Cut an opening into the furnace return duct not less than 9' 10" from forced air unit drop: (A+B+C).
- Connect this opening to the stale air intake port on the HRV/ERV as shown.

Fresh air distribution: (Same instruction as for Method 1 or Method 2, section 3.5.2)

For Method 2 (return-return), make sure there is a distance of at least 3 feet between both connections to the furnace.

CAUTION

If using Method 2, make sure the furnace blower operation is synchronized with the HRV/ERV operation! See Section 5.

NOTE: For Method 1, it is not essential to synchronize the furnace blower operation with the HRV/ERV operation, but we recommend it.

3. INSTALLATION (CONT'D)

3.6 INSTALLING INSULATED FLEXIBLE DUCTS

CAUTION

Make sure the vapor barrier on the insulated ducts does not tear during installation to avoid condensation within the ducts.

3.6.1 CONNECTION TO THE UNIT PORTS

Use the following procedure for connecting the insulated flexible ducts to the unit ports (Exhaust air to outdoor and Fresh air from outdoor). Refer to identification labels before performing any duct and port connection.

CAUTION

Avoid compressing the insulation when you pull the tape tightly around the joint. Compressed insulation loses its insulation properties and causes water dripping due to condensation on the exterior surface of the duct.

- 1 For both remaining ducts, pull back the insulation to expose the interior flexible duct.
- 2 Connect the interior flexible duct to the smaller part of the inner ring of the port using a tie wrap.
- 3 Pull the insulation over the joint and tuck it between the inner and outer rings of the port. Pull the vapor barrier over the insulation and over the outer ring of the port.
- 4 Apply duct tape gently to the joint in order to make an airtight seal. See figures at right.

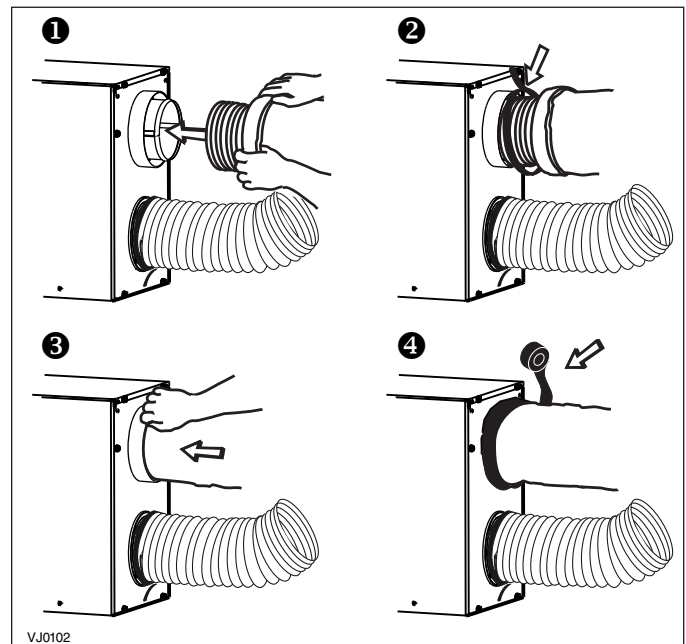

3.6.2 LOCATING EXTERIOR PORTS

Choose an appropriate location for installing the exterior ports:

- There must be a minimum distance of 6' between the hoods to avoid cross-contamination
- There must be a minimum distance of 18" from the ground

⚠ WARNING

Make sure the fresh air intake port is located at least 6 feet away (or more, as per applicable building codes or standards) from sources of contamination such as:

- **Dryer exhaust, high efficiency furnace vent, central vacuum vent**
- **Gas meter exhaust, gas barbecue grill**
- **Garbage bin**
- **Any exhaust from a combustion source.**

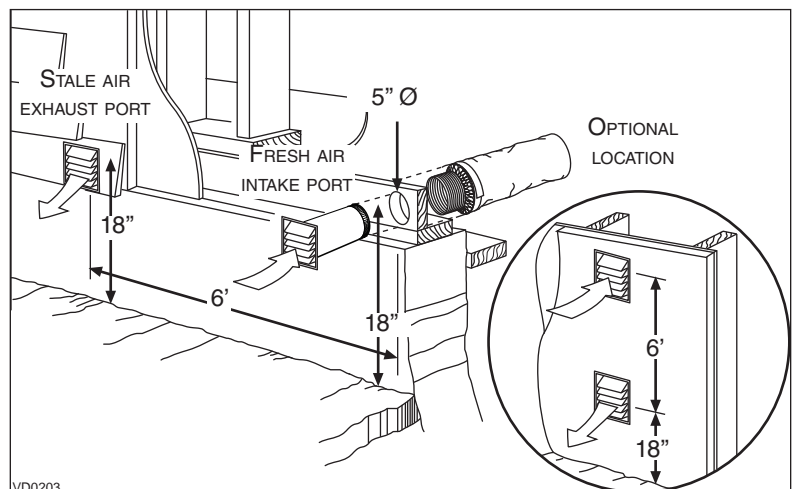

3. INSTALLATION (CONT'D)

3.7 CONNECTING INSULATED DUCTS TO EXTERIOR PORTS

- For each exterior port, using a jig saw, cut a 5" diameter hole in the exterior wall.
- From the outdoor, slide the exterior port in place and attach it to the exterior wall, using 2 no. 8 x 1½" provided screws. Seal the outline with silicone.
- From the inside, pull back the insulation to expose the flexible duct and, using a tie wrap, attach it to the exterior port rigid duct. Carefully seal with duct tape. Pull the insulation over the joint. Pull the vapor barrier over the insulation and over the joint. Apply gently duct tape to the joint making an airtight seal. See illustration at right.

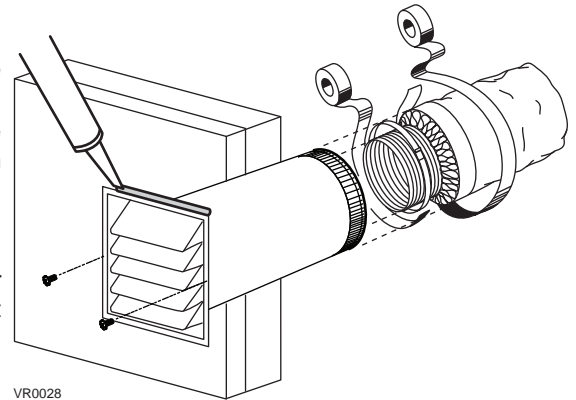

VR0028

3.8 INSTALLING TANDEM® TRANSITION* KIT

If desired, it is possible to perform insulated ducts connection with the outdoor using the Tandem transition kit (purchase separately, part number VTYIK1). The joist opening needed to install the Tandem transition must be 9¾" minimum. The maximum height of the Tandem transition is 8¾". To connect the insulated flexible ducts to the Tandem transition (Exhaust air to outdoor and Fresh air from outdoor), follow the instructions included with the kit.

*Patented.

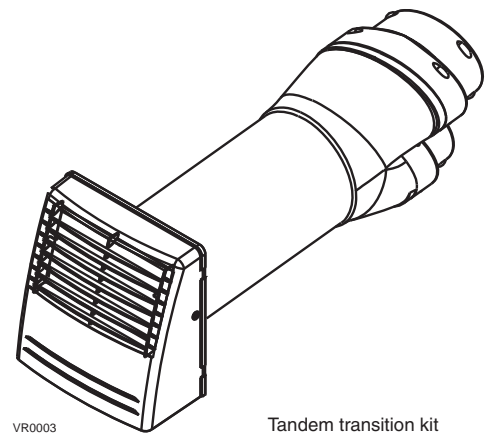

VR0003

Tandem transition kit

3.9 CONNECTING THE DRAIN

CAUTION

A drain tubing (included) must be installed for all HRV units. For ERV units, it is not required, however, it is recommended for climates where the outdoor temperature typically remains below -13°F, (over a 24-hour period) for several days in a row, combined with an indoor humidity of 40% or higher.

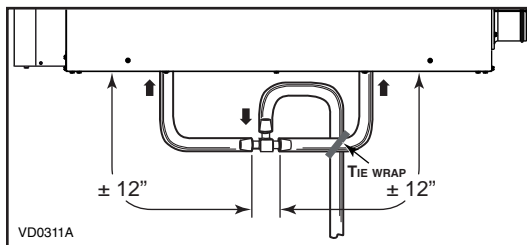

VD0311A

Cut two sections of plastic tubing, approximately 12" long, and connect each one to both inner drain fittings located under the unit as shown.

Join these both sections to the "T" junction and main tube as shown, to prevent the unit from drawing unpleasant odors from the drain source.

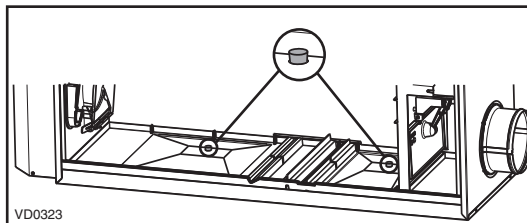

VD0323

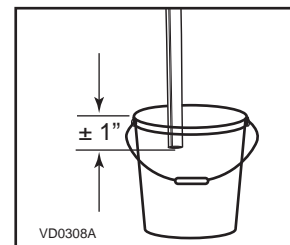

VD0308A

Run the tube to the floor drain or to an alternative drain pipe or pail.

IMPORTANT

If using a pail to collect water, locate the tube end approximately 1" from the top of the pail in order to prevent water from being drawn back up into the unit.

- NOTES: 1. For ERV unit, remove both drain plugs inside the unit prior to install tubing.
2. ERV core and blower assembly removed from illustration to ease understanding.

4. CONTROLS

4.1 INTEGRATED CONTROL

These units are equipped with an integrated control located under the electrical compartment of the unit. Use the push button (1) to control the unit; the LED (2) will then show which mode the unit is in (see illustration at right).

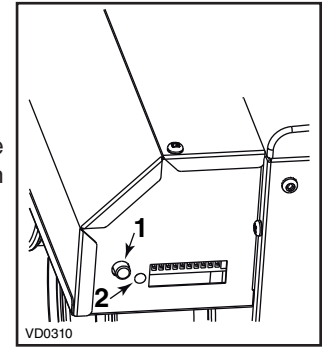

Refer to table below to see how to operate the unit using its integrated control.

PRESS ON PUSH BUTTON	LED COLOR	RESULTS
ONCE	AMBER	UNIT IS ON LOW SPEED
TWICE	GREEN	UNIT IS ON HIGH SPEED
THREE TIMES	NO LIGHT	UNIT IS OFF

If a problem occurs during the unit operation, its integrated control LED (2) will blink. The color of the blinking light depends on the type of error detected. Refer to Section 9 Troubleshooting on last pages for further details.

NOTE: The integrated control **must be turned OFF** to use an optional main control.

4.2 BOOTING SEQUENCE

The unit booting sequence is similar to a personal computer boot sequence. Each time the unit is plugged after being unplugged, or after a power failure, the unit will perform a 30-second booting sequence before starting to operate.

During the booting sequence, the integrated defrost control LED will light AMBER for 5 seconds, and then will shut off for 2 seconds. After that, the LED will light RED for the rest of the booting sequence. During this RED light phase, the unit is checking and resetting the motorized damper position. Once the motorized damper position completely set, the RED light turns off and the booting sequence is done.

4.3 SETTING EXTENDED DEFROST

The unit is factory set to normal defrost. In cold region (outdoor temperature -17°F and lower), it may be necessary to setup extended defrost. During **the first 3 seconds of booting sequence**, while the integrated control LED is AMBER, press on push button for about 3 seconds. The LED will blink GREEN the number of times corresponding to the actual defrost mode of the unit.

NOTE: During setting extended defrost, while the push button is pressed, the LED will light RED to indicate the signal has been received.

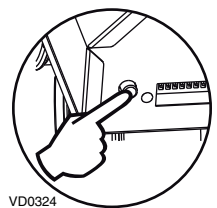

Refer to table below to modify the defrost cycle of the unit. It is possible to change the selection as many times needed.

DEFROST CYCLE	PRESS ON PUSH BUTTON	LED BLINKS GREEN
1 NORMAL (HRV UNIT)	ONCE	1 TIME
2 EXTENDED (HRV UNIT)	TWICE	2 TIMES
3 NORMAL (ERV UNIT)	THREE TIMES	3 TIMES
4 EXTENDED (ERV UNIT)	FOUR TIMES	4 TIMES

To exit setting extended defrost, press 3 seconds on push button OR wait 60 seconds; the LED will blink and shut off, then light RED (the unit returns in its booting sequence).

4. CONTROLS (CONT'D)

4.4 ELECTRICAL CONNECTION TO WALL CONTROLS

For more convenience, this unit can also be controlled using an optional main wall control.

NOTES: 1. The integrated control must be turned OFF to use an optional main control.

2. If an optional auxiliary control is used, if activated, this auxiliary control will override the optional main control.

⚠ WARNING

Always disconnect the unit before making any connections. Failure in disconnecting power could result in electric shock or damage of the wall control or electronic module inside the unit.

CAUTION

Never install more than one main wall control per unit. Make sure that the wires do not short-circuit between themselves or by touching any other components on the wall control. Avoid poor wiring connections. To reduce electrical interference (noise) potential, do not run wall control wiring next to control contactors or near light dimming circuits, electrical motors, dwelling/building power or lighting wiring, or power distribution panel.

Use the terminal connector included in the installation kit to perform the electrical connection for main and optional wall controls. Check if all wires are correctly inserted in their corresponding holes in the terminal block. (A wire is correctly inserted when its orange receptacle is lower than another one without wire. On picture at right, wire **A** is correctly inserted, but not wire **B**.)

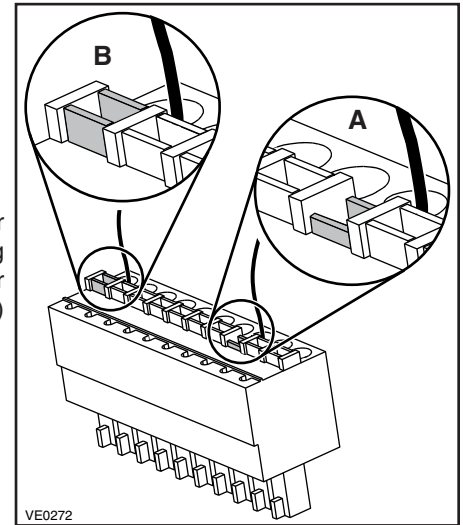

4.4.1 ELECTRICAL CONNECTION TO VT8W MAIN WALL CONTROL

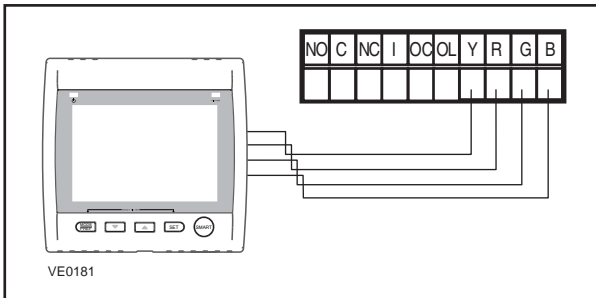

4.4.2 ELECTRICAL CONNECTION TO VT7W MAIN WALL CONTROL

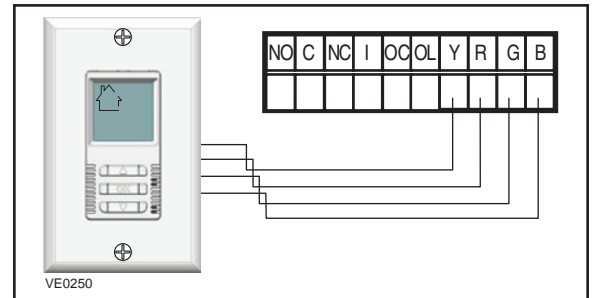

4.4.3 ELECTRICAL CONNECTION TO VT4W MAIN WALL CONTROL

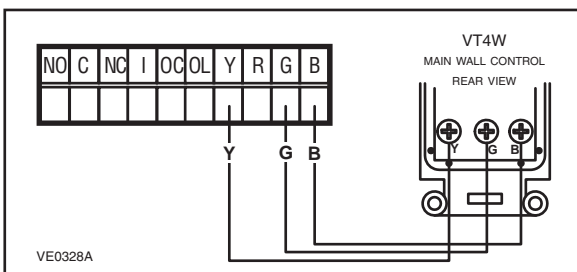

4.4.4 ELECTRICAL CONNECTION TO VT6W MAIN WALL CONTROL

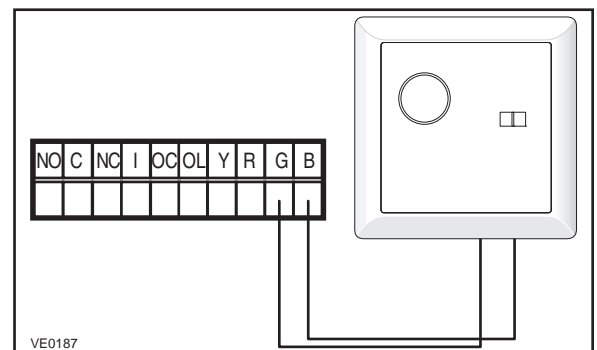

4. CONTROLS (CONT'D)

4.4 ELECTRICAL CONNECTION TO WALL CONTROLS (CONT'D)

4.4.5 ELECTRICAL CONNECTION TO OPTIONAL AUXILIARY WALL CONTROLS

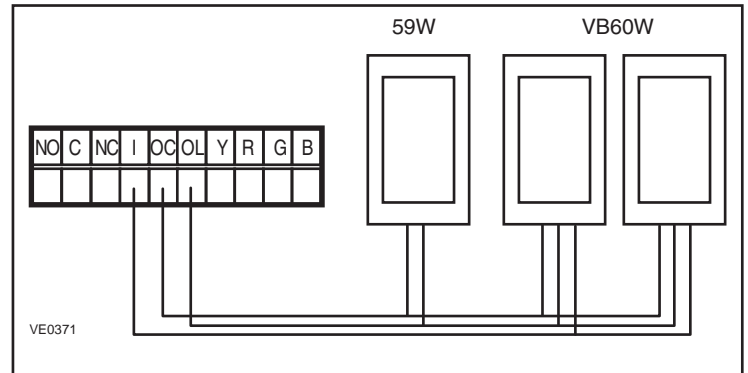

Once the control(s) connections have been made, insert the terminal connector in the electrical compartment interface. Plug the unit.

NOTE: Refer to *Main and auxiliary wall control User Guide* (included with the ventilation unit) for information about the use of optional main and auxiliary wall controls.

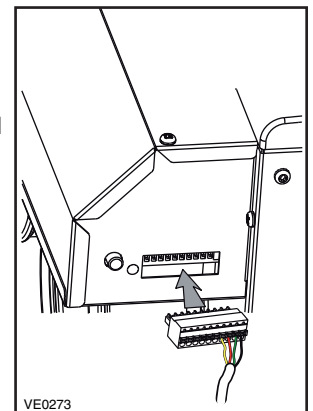

5. ELECTRICAL CONNECTION TO THE FURNACE

⚠ WARNING

Never connect a 120-volt AC circuit to the terminals of the furnace interlock (standard wiring). Use only the low voltage class 2 circuit of the furnace blower control.

For a furnace connected to a cooling system:

On some older thermostat, energizing the “R” and “G” terminals at the furnace has the effect of energizing “Y” terminal at the thermostat and thereby turning on the cooling system. If you identify this type of thermostat, you must use the ALTERNATE FURNACE INTERLOCK WIRING.

STANDARD FURNACE INTERLOCK WIRING

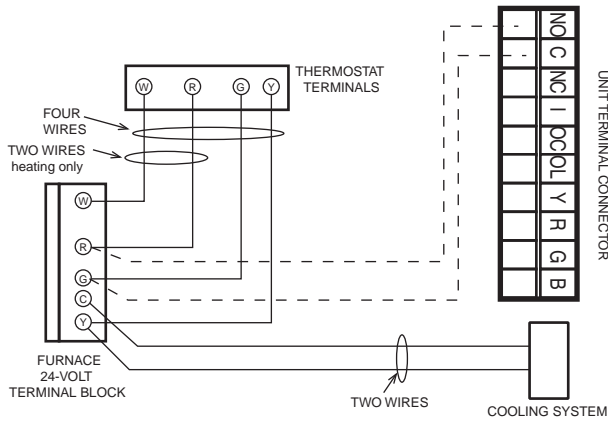

VE0108A

ALTERNATE FURNACE INTERLOCK WIRING

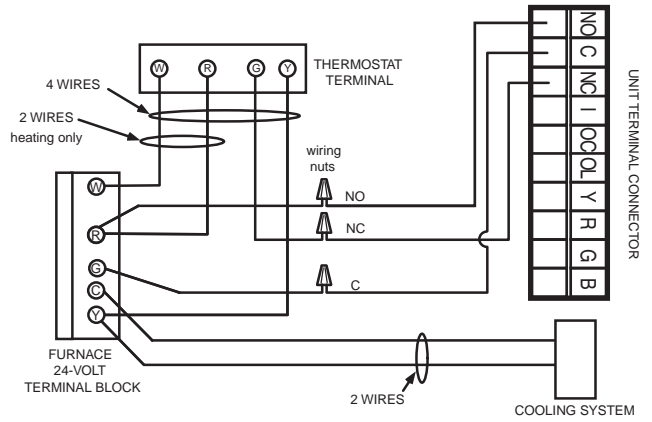

6. WIRING DIAGRAM

⚠ WARNING

- Risk of electric shocks. Before performing any maintenance or servicing, always disconnect the unit from its power source.
- This product is equipped with an overload protection (fuse). A blown fuse indicates an overload or a short-circuit situation. If the fuse blows, unplug the product from the outlet. Discontinue using the unit and contact technical support.

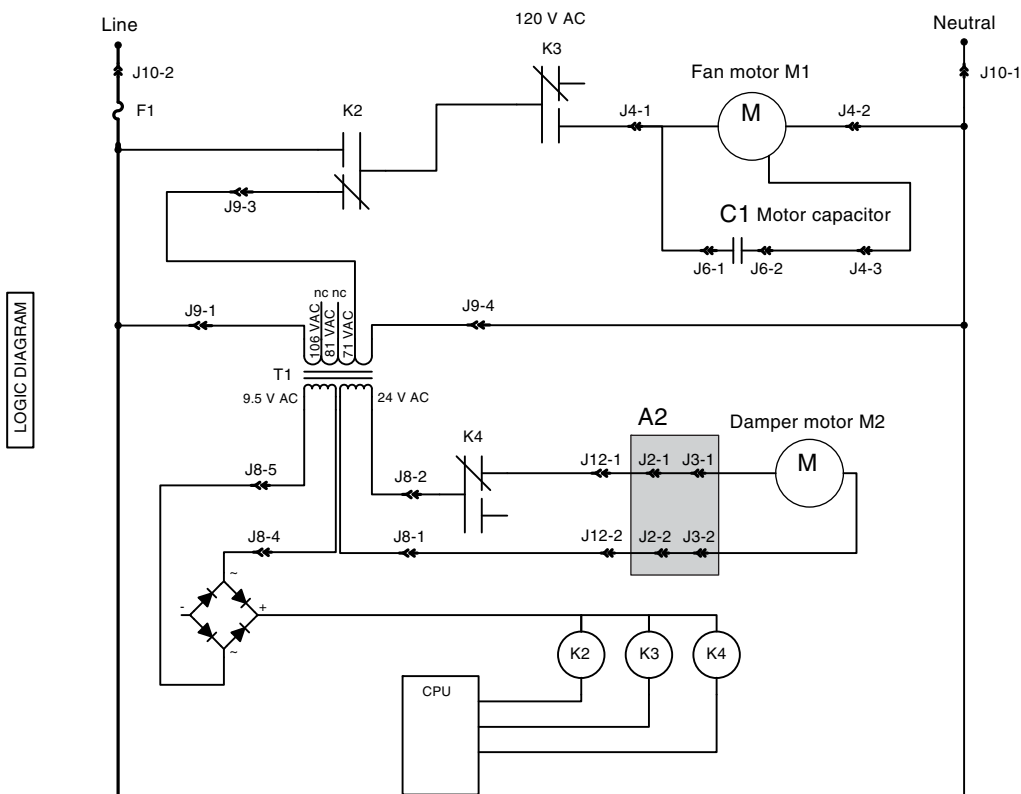
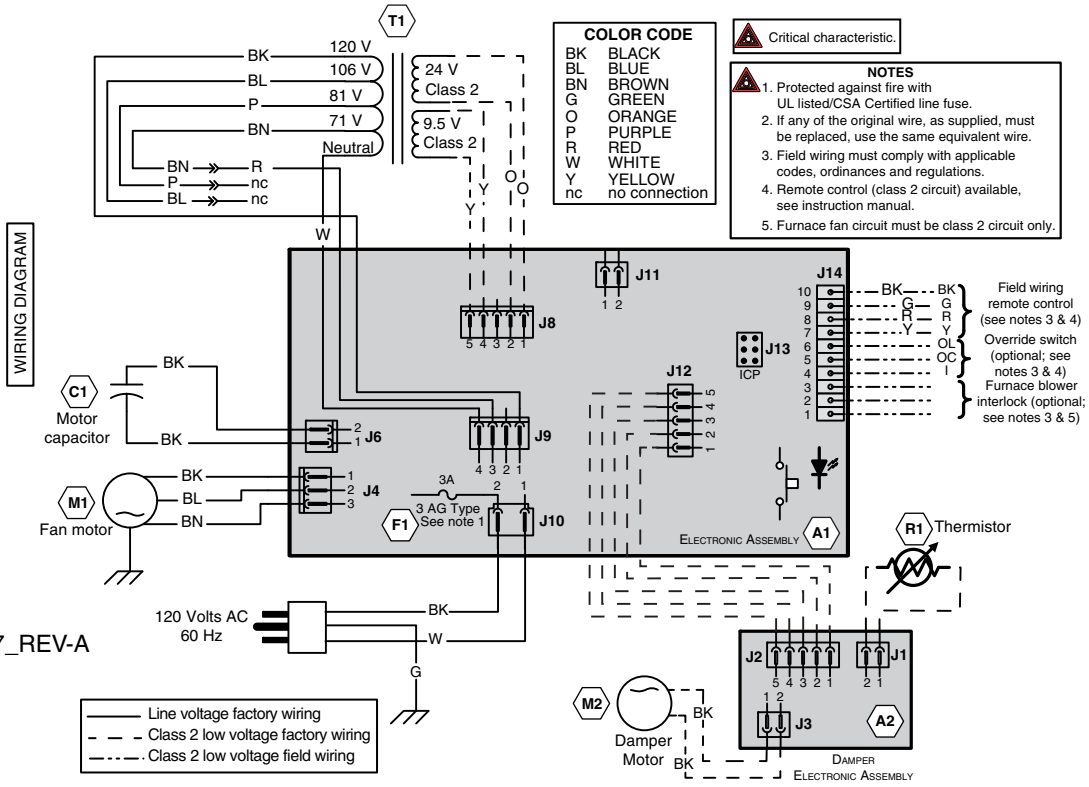

7. BALANCING THE UNIT

7.1 WHAT YOU NEED TO BALANCE THE UNIT

- A magnehelic gauge capable of measuring 0 to 0.5 inch of water (0 to 125 Pa) and 2 plastic tubes.
- The balancing chart located on the unit door.

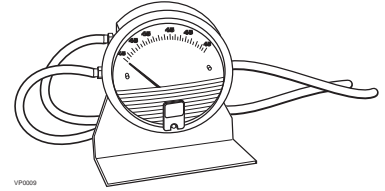

7.2 PRELIMINARY STAGES TO BALANCE THE UNIT

- Seal all the unit ductwork with tape. Close all windows and doors.
- Turn off all exhaust devices such as range hood, dryer and bathroom fans.
- Make sure the balancing dampers are fully open.

NOTE: The **balancing dampers are NOT INCLUDED**; to be supplied by others. Install the balancing dampers in Fresh air to building duct and exhaust air from building duct (**A** and **B** on illustration below), at the more convenient place.

- Make sure all filters are clean (if it is not the first time you balance the unit).

7.3 BALANCING PROCEDURE

1. Set the unit to high speed.

Make sure that the furnace/air handler blower is ON if the installation is in any way connected to the ductwork of the cold air return. If not, leave furnace/air handler blower OFF. If the outdoor temperature is below 32°F, make sure the unit is not running in defrost while balancing. (By waiting 10 minutes after plugging the unit in, you are assured that the unit is not in a defrost cycle.)

2. Place the magnehelic gauge on a level surface and adjust it to zero.

3. Connect tubing from gauge to exhaust air flow pressure taps (see illustration at right).

Be sure to connect the tubes to their appropriate high/low fittings. If the gauge drops below zero, reverse the tubing connections.

NOTE: It is suggested to start with the exhaust air flow reading because the exhaust has typically more restriction than the fresh air, especially in cases of fully ducted installations or source point ventilation. Place the magnehelic gauge upright and level. Record equivalent air flow of the reading according to the balancing chart.

4. Move tubing to fresh air flow pressure taps (see diagram).

Adjust the fresh air balancing damper (**A**) until the fresh air flow is approximately the same as the exhaust air flow. If fresh air flow is less than exhaust air flow, then go back and adjust the exhaust balancing damper (**B**) to equal the fresh air flow.

5. Secure both dampers in place with a fastening screw.

6. Write the required air flow information on a label and affix it near the unit for future reference (date, maximum speed air flows, your name, phone number and business address).

NOTE: The unit is considered balanced even if there is a difference of ± 10 cfm (or ± 5 l/s) between the two air flows.

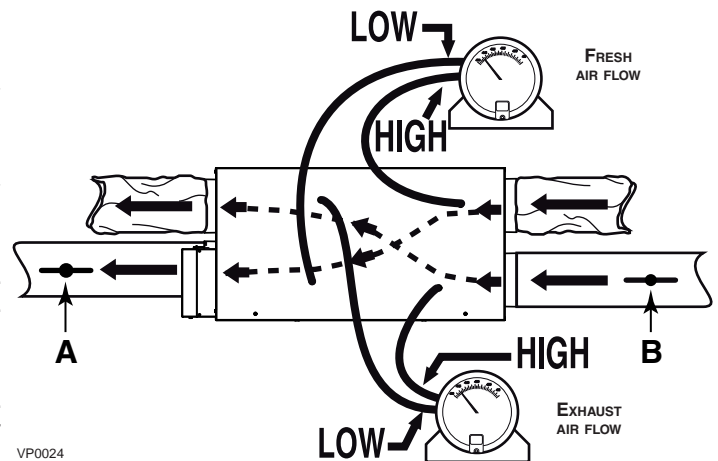

8. SERVICE PARTS

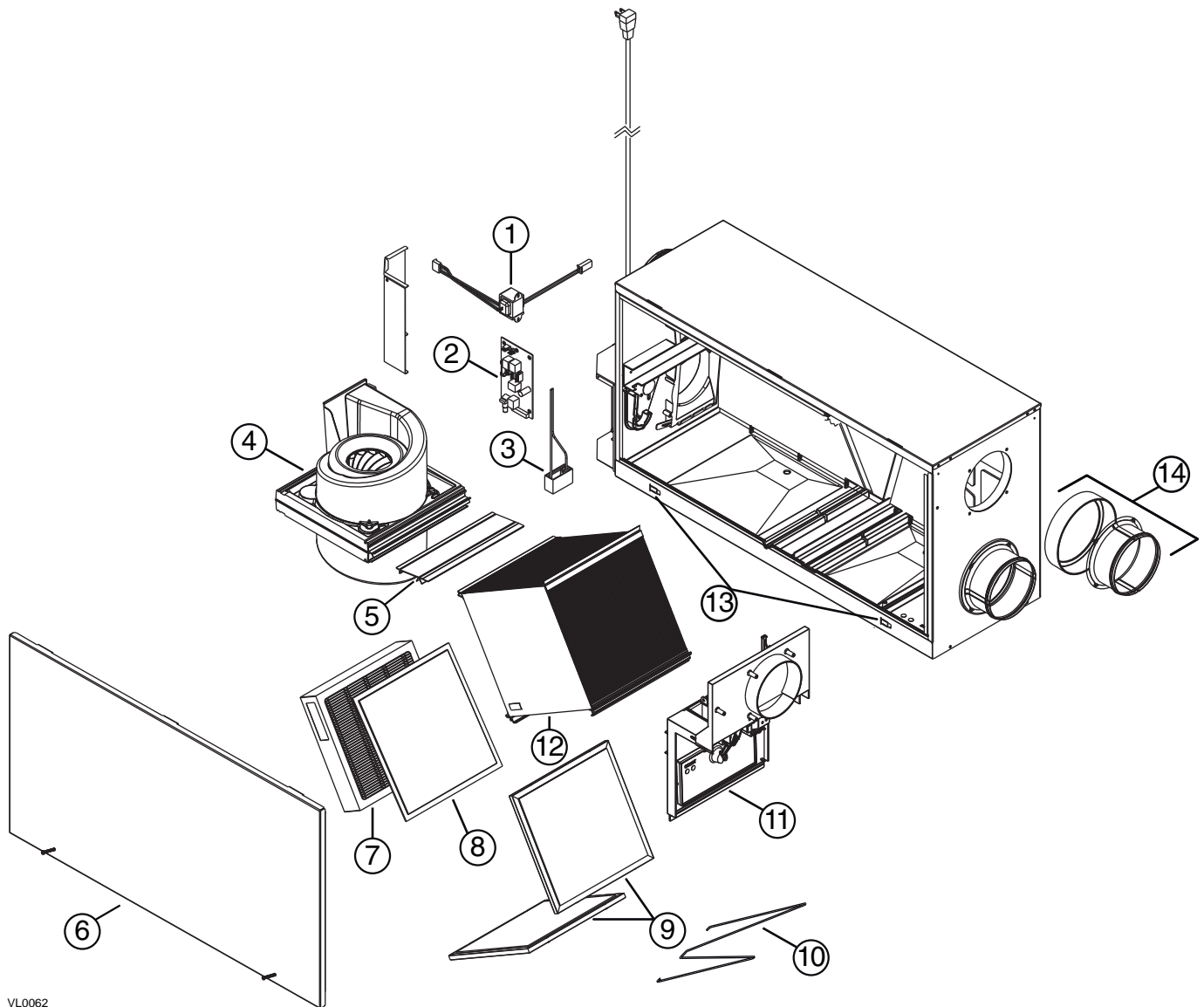

VL0062

ITEM	DESCRIPTION	QTY.	HRVH100S	ERVH100S
1	TRANSFORMER	1	SV61545	SV61545
2	ELECTRONIC BOARD	1	SV61415	SV61184
3	CAPACITOR 6 μ F	1	SV61550	SV61550
4	BLOWER ASSEMBLY	1	SV61552	SV61552
5	CORE BRACKET	1	SV61553	SV61553
6	DOOR ASSEMBLY	1	SV63625	SV63625
7	HEPA FILTER KIT ¹	1	SV21293	SV21293
8	PREFILTER KIT FOR HEPA FILTER ²	1	SV61561	SV61561
9	CORE FILTER	2	SV61563	SV61562
10	BOTTOM FILTER RETAINING WIRE	1		SV61564
11	DAMPER SYSTEM ASSEMBLY	1	SV61565	SV61565
12	HEAT RECOVERY CORE	1	SV61567	
	ENERGY RECOVERY CORE	1		SV61410
13	BRACKET WITH RETAINING NUT	2	SV61411	SV61411
14	DOUBLE COLLAR PORT	2	SV61569	SV61569

¹ HEPA FILTER KIT INCLUDES 2 PREFILTERS.

² PREFILTER KIT INCLUDES 2 PREFILTERS.

REPLACEMENT PARTS AND REPAIRS

In order to ensure your ventilation unit remains in good working condition, you must use Broan-NuTone LLC genuine replacement parts only. Broan-NuTone LLC genuine replacement parts are specially designed for each unit and are manufactured to comply with all the applicable certification standards and maintain a high standard of safety. Any third party replacement part used may cause serious damage and drastically reduce the performance level of your unit, which will result in premature failing. Broan-NuTone LLC recommends to contact a certified service depot for all replacement parts and repairs.

9. TROUBLESHOOTING

⚠ WARNING

Risk of electric shocks. Electronic board connections must be checked by qualified personnel only.

If the unit does not work properly, reset the unit by unplugging it for one minute and then replug it. If it is still not working properly, refer to table below.

If the integrated control LED of the unit is flashing, this means the unit sensors detected a problem. See the table below to know where the problem occurs on the unit.

LED COLOR	ERROR TYPE	ACTION	UNIT STATUS
LED flashes GREEN	Thermistor error	Replace thermistor	Unit works but will defrost frequently
LED flashes AMBER	Damper error	Go to point 5	Unit does not work

	PROBLEMS	POSSIBLE CAUSES	YOU SHOULD TRY THIS
1	The error code E1 is displayed on VT8W or VT7W wall control screen.	<ul style="list-style-type: none"> The wires may be in reverse position. The wires may be broken. The wires may have a bad connection. 	<ul style="list-style-type: none"> Ensure that the color coded wires have been connected to their appropriate places. Inspect every wire and replace any that is damaged. Ensure the wires are correctly connected.
2	There is no outdoor temperature displayed on VT8W wall control screen — — .	<ul style="list-style-type: none"> The unit thermistor is defective (the integrated control LED of the unit must flash GREEN). 	<p>NOTE: At its very start-up or after a power failure, it takes some minutes before the outdoor temperature appears on screen. The delay duration depends on which operation mode the wall control is set. The shortest delay is obtained when the wall control is set on MIN or MAX in VENT Mode.</p> <ul style="list-style-type: none"> Replace the unit thermistor.
3	VT8W or VT7W wall control screen alternates between normal display and E3.	<ul style="list-style-type: none"> The VT8W or VT7W wall control may be defective. 	<ul style="list-style-type: none"> Replace the VT8W or VT7W wall control.
4	Unit does not work.	<ul style="list-style-type: none"> The circuit board may be defective. The fuse may be defective. 	<ul style="list-style-type: none"> Unplug the unit. Disconnect the main control and the optional auxiliary control(s) (if need be). Jump G and B terminals. Plug the unit back and wait about 10 seconds. If the motors run on high speed and the damper opens, the circuit board is not defective. Unplug the product from the outlet. Check if fuse F1 is blown. In that case, discontinue using the unit and contact technical support.
5	The damper actuator does not work.	<ul style="list-style-type: none"> The damper actuator or the integrated damper mechanism may be defective. The circuit board or the transformer may be defective. 	<ul style="list-style-type: none"> Unplug the unit. Disconnect the main control and the optional controls(s) (if need be). Wait 10 seconds and plug the unit back. Check if the damper opens. If not, use a multimeter and check for 24 VAC on J12-1 and J12-2 (in electrical compartment). If there is 24 VAC, replace the entire damper assembly. NOTE: It is normal to experience a small delay (7-8 seconds) before detecting the 24 VAC signal at starting-up. This signal will stay during 17-18 seconds before disappearing. If there is no 24 VAC, check for 24 VAC between J8-1 and J8-2. If there is 24 VAC, replace the circuit board, and if there is no 24 VAC, change the transformer.



VE0097

9. TROUBLESHOOTING (CONT'D)

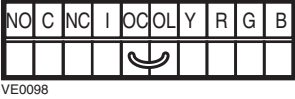
	PROBLEMS	POSSIBLE CAUSES	YOU SHOULD TRY THIS
6	The wall control does not work.	<ul style="list-style-type: none"> The wires may be in reverse position. The wires may be broken. The wire in the wall OR the wall control may be defective. 	<ul style="list-style-type: none"> Ensure that the color coded wires have been connected to their appropriate places. Inspect every wire and replace any that are damaged. Remove the wall control and test it right beside the unit using another shorter wire. If the wall control works there, change the wire. If it does not, change the wall control.
7	The VB60W push button timer does not work OR its indicator light does not stay on.	<ul style="list-style-type: none"> The wires may be in reverse position. The VB60W button may be defective. 	<ul style="list-style-type: none"> Ensure that the color coded wires have been connected to their appropriate places. Jump the OL and OC terminals. If the unit switch to high speed, remove the VB60W push button and test it right beside the unit <small>VE0098</small>  <ul style="list-style-type: none"> using another shorter wire. If it works here, change the wire. If it doesn't, change the VB60W push button.
8	The motor does not work.	<ul style="list-style-type: none"> The fuse may be defective. The motor may be defective. The motor or capacitor may be defective. 	<ul style="list-style-type: none"> Unplug the product from the outlet. Check if fuse F1 is blown. In that case, discontinue using the unit and contact technical support. NOTE: Refer to Section 6 <i>Wiring diagram</i>. If the voltage reading is 120 VAC on J4, change the defective motor. Using a multimeter, check the ohms value on motor connector. For BLUE and BLACK motor wires, the right value is ± 43 ohms. For BLUE and BROWN motor wires, the right value is ± 48 ohms. For BROWN and BLACK motor wires, the right value is ± 91 ohms. If the ohms values are the same, the motor is not defective. Replace the motor capacitor.
9	The defrost cycle does not work (the fresh air duct is frozen) OR the fresh air distributed is very cold.	<ul style="list-style-type: none"> Ice deposits may be hindering the damper operation. The damper rod or the port damper itself may be broken. The damper actuator or circuit board may be defective. 	<ul style="list-style-type: none"> Remove the ice. Inspect these parts and replace if necessary. See point 5.
10	The integrated defrost control push button does not work.	<ul style="list-style-type: none"> The 30-second boot sequence is not completed. 	<ul style="list-style-type: none"> See Section 4.1 <i>Booting Sequence</i>.



USER GUIDE

HEAT RECOVERY VENTILATOR MODEL HRVH100S AND ENERGY RECOVERY VENTILATOR MODEL ERVH100S

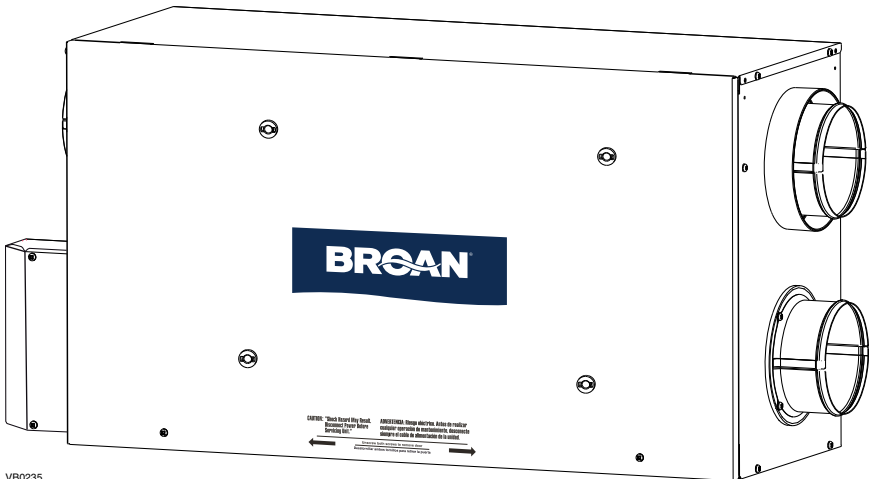

VB0235

**READ AND SAVE THESE INSTRUCTIONS
INSTALLER: LEAVE THIS MANUAL WITH HOMEOWNER**



These products earned the ENERGY STAR® by meeting strict energy efficiency guidelines set by Natural Resources Canada and the US EPA. They meet ENERGY STAR requirements only when used in Canada.

22735 rev. 01

Congratulations!

You have made an excellent choice! The operating principle of your Heat Recovery Ventilator or your Energy Recovery Ventilator will give you personal comfort you have never known before.

We have prepared this User Guide especially for you. Please read it carefully to ensure you obtain full benefit from your unit. Over the coming months, you will increasingly appreciate the feeling of living in a more comfortable house.

Please take note that this manual uses the following symbols to emphasize particular information:

⚠ WARNING

Identifies an instruction which, if not followed, might cause serious personal injuries including possibility of death.

CAUTION

Identifies an instruction which, if not followed, may severely damage the unit and/or its components.

NOTE: Indicates supplementary information needed to fully complete an instruction.

We welcome any suggestions you may have concerning this guide and/or the unit, or ways to better serve you. Please forward all correspondence at the address below:

CAUTION

Make sure at all times that the outside intake and exhaust hoods are free from any snow during the winter season. It is important to check your unit during a big snow storm, so it doesn't draw in any snow. If this is the case, please operate the unit in recirculation mode, or turn it OFF for a few hours. Do not use your unit during construction or renovation of your house or when sanding drywall. This type of dust may damage your system. Since the electronic control system of the unit is incorporated with a microprocessor, it may not operate correctly because of external noise or very short power failure. If this happens, unplug the unit and wait approximately 10 seconds. Then, plug the unit in again. At least once a year, the unit mechanical and electronic parts should be inspected by qualified service personnel.

CAUTION

When leaving the house for a long period of time (more than two weeks), a responsible person should regularly check if the unit operates adequately. If the ductwork runs through an unconditioned space (e.g.: attic), the unit must operate continuously except when performing maintenance and/or repair. Also, the ambient temperature of the house should never drop below 65°F.

TABLE OF CONTENTS

1. SERVICE PARTS		3
2. CONTROLS		4
2.1 BOOTING SEQUENCE		4
2.2 OPTIONAL MAIN AND AUXILIARY CONTROLS		4
3. MAINTENANCE		5-7
3.1 QUARTERLY MAINTENANCE		5-6
3.2 ANNUAL MAINTENANCE		7
4. TROUBLESHOOTING		8

1. SERVICE PARTS

All parts listed in the following table are available where you have bought your unit.

NOTE: Please note that parts not listed are not available; those parts require assembly knowledge that only manufacturer can guarantee.

DESCRIPTION	HRVH100S	ERVH100S	QUANTITY
HEPA filter (1 per kit) and prefilter (2 per kit) kit	SV21293	SV21293	1
Prefilter (2 per kit)	SV61561	SV61561	1
Core filter	SV61563	SV61562	2

REPLACEMENT PARTS AND REPAIRS

In order to ensure your ventilation unit remains in good working condition, you must use Broan-NuTone LLC genuine replacement parts only. Broan-NuTone LLC genuine replacement parts are specially designed for each unit and are manufactured to comply with all the applicable certification standards and maintain a high standard of safety. Any third party replacement part used may cause serious damage and drastically reduce the performance level of your unit, which will result in premature failing. Broan-NuTone LLC recommends to contact a certified service depot for all replacement parts and repairs.

2. CONTROLS

This unit is equipped with an integrated control located under the electrical compartment of the unit. Use the push button (1) to control the unit; the LED (2) will then show which mode the unit is in (see illustration at right and table below).

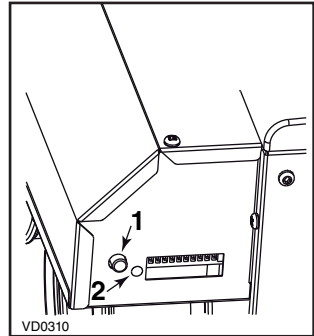

LED COLOR	RESULTS
AMBER	UNIT IS ON LOW SPEED
GREEN	UNIT IS ON HIGH SPEED
NO LIGHT	UNIT IS OFF OR CONTROLLED BY A MAIN CONTROL

NOTE: The integrated control **must be turned OFF** to use an optional main control.

If a problem occurs during the unit operation, its integrated control LED (2) will blink. The color of the blinking light depends on the type of error detected. Refer to Section 4 Troubleshooting on last page for further details.

2.1 BOOTING SEQUENCE

The unit booting sequence is similar to a personal computer boot sequence. Each time the unit is plugged after being unplugged, or after a power failure, the unit will perform a 30-second booting sequence before starting to operate.

During the booting sequence, the integrated defrost control LED will light AMBER for 5 seconds, and then will shut off for 2 seconds. After that, the LED will light RED for the rest of the booting sequence. During this RED light phase, the unit is checking and resetting the motorized damper position. Once the motorized damper position completely set, the RED light turns off and the booting sequence is done.

NOTE: No command will be taken until the unit is fully booted.

2.2 OPTIONAL MAIN AND AUXILIARY CONTROLS

For more convenience, this unit can also be controlled using an optional main wall control. Many models can be used, but only one main wall control can be connected to the unit.

- NOTES: 1. The integrated control **must be turned OFF** to use an optional main control.
2. If an optional auxiliary control is used, if activated, the operation of this auxiliary control will override the optional main control operation.

For more information about the available controls and their operation modes, refer to the *Main and auxiliary wall control User Guide* (included with the ventilation unit).

3. MAINTENANCE

⚠ WARNING

Risk of electric shock. Before performing any maintenance, always turn off and disconnect the unit from its power source. When cleaning the unit, it is recommended to wear safety glasses and gloves.

This unit needs quarterly and annual maintenances.

Refer to the illustration below to identify the inner removable parts of your unit:

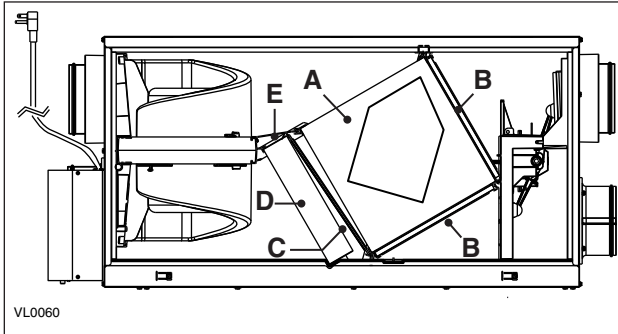

- A. Heat or energy recovery core
- B. Heat or energy recovery core filters (2)
- C. Prefilter
- D. HEPA filter
- E. Core bracket

3.1 QUARTERLY MAINTENANCE

- ❶ Turn the unit OFF and unplug it.

- ❷ Using a Phillips or a Robertson screwdriver, loosen both door screws (A).

NOTE: The screws will stay attached to the door.

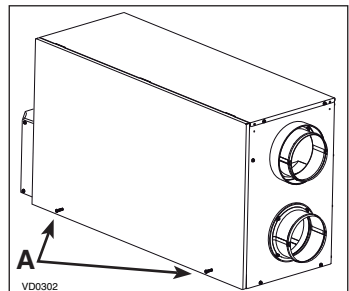

3. MAINTENANCE (CONT'D)

3.1 QUARTERLY MAINTENANCE (CONT'D)

- 3 Open (B) and lift out the door (C).

CAUTION

In order to prevent damages to the door hooks, do not open completely the unit door; tilt it about 3" from the unit base and lift it up. See illustration at right.

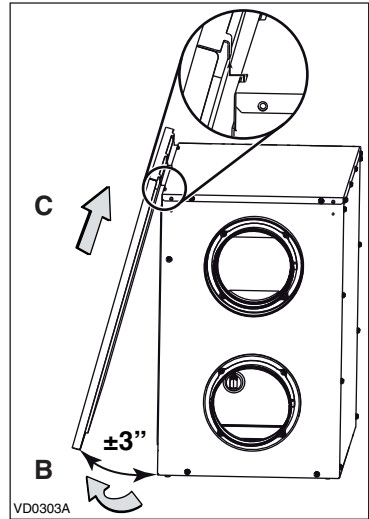

- 3 Slide out the heat or energy recovery core, the core bracket the bottom filter retaining wire and all the filters.

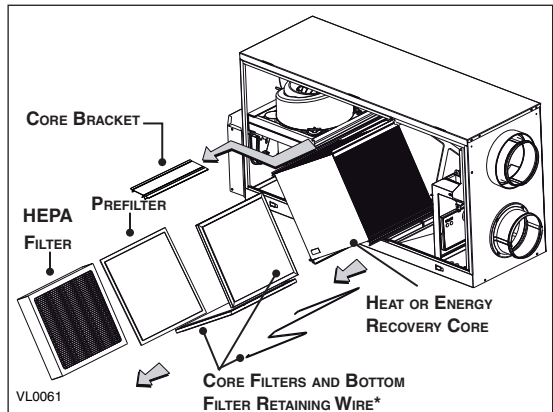

*Bottom filter retaining wire only on ERVH100S unit.

- 4 Clean the inside wall of the unit with a damp cloth, then wipe with a dry one.
- 5 Remove dust on core using a vacuum cleaner with a soft brush attachment. Wash both core filters under hot water with mild soap. Rinse thoroughly and let dry completely.
- 6 Reinstall the recovery core with its filters and the retaining wire (if present).
NOTE: The recovery core must be reinstalled BEFORE the core bracket. Reinstall the HEPA filter but before reinstalling the prefilter, look at the installation date on HEPA filter frame. If there are more than 6 months passed, discard the prefilter and install a new one, but keep the HEPA filter.
- 7 Reinstall the door, plug back the unit and turn it on.
NOTE: The unit will return to its previous setting after a 30-second delay for boot sequence.

3. MAINTENANCE (CONT'D)

3.2 ANNUAL MAINTENANCE

Perform steps ① to ⑤ of the regular maintenance then continue with the followings:

EXCLUSIVELY FOR HRVH100S UNITS

- ⑥ Allow the heat recovery core to soak for 3 hours in a solution of warm water and mild soap (dishwashing liquid). Rinse carefully, drain off water and reinstall with its filters.

EXCLUSIVELY FOR ERVH100S UNITS

CAUTION

Do not soak in water. The energy recovery core can easily be damaged especially if it is soaked.

- ⑥ Use a vacuum cleaner with a soft brush attachment to remove dust on core, then reinstall with its filters.

ALL UNITS

NOTE: The recovery core must be reinstalled BEFORE the core bracket. Discard HEPA filter and its prefilter and replace with new ones. DO NOT FORGET TO WRITE THE INSTALLATION DATE ON NEW HEPA FILTER FRAME.

- ⑦ Check the exterior hoods; make sure there are no leaves, twigs, ice or snow that could be drawn into the vent. Clean if necessary.

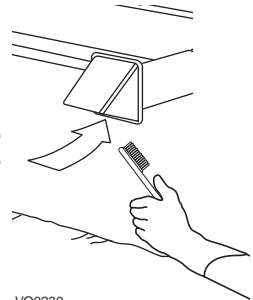

- ⑧ Reinstall the door, plug back the unit and turn it on.

NOTE: The unit will return to its previous setting after a 20-second delay for boot sequence.

4. TROUBLESHOOTING

WARNING

Shock hazard. Never open the electronic box. No user-serviceable parts inside. There is a fuse on the electronic board. Never attempt to replace it. Refer servicing to qualified service personnel.

If the unit does not work properly, reset the unit by unplugging it for one minute and then replug it. If it is still not working properly, refer to table below.

	PROBLEMS	YOU SHOULD TRY THIS
1	Unit does not work.	<ul style="list-style-type: none"> • See if the unit is plugged in. • Check if the upper left port is free from packaging material. • See if the unit is receiving power from the house circuit breaker or fuse.
2	Condensation on windows (air too humid).	<ul style="list-style-type: none"> • Operate the unit on maximum speed ventilation until the situation is corrected. • Leave curtains half-open to allow air circulation. • Store all firewood in a closed room with a dehumidifier or in a well ventilated room, or store the wood outside. • Do not adjust the thermostat of your heating system below 64°F.
3	Inside air too dry (on cold season).	<ul style="list-style-type: none"> • Temporarily use a humidifier. • Operate the unit in recirculation mode (if available).
4	Air too cold at the air supply grille (on cold season).	<ul style="list-style-type: none"> • Check if the exterior hood are not blocked, specifically the exhaust air to outside one. • Operate the unit in low speed ventilation or in intermittent or recirculation mode (if available).
5	The LED of the integrated control is blinking GREEN.	<ul style="list-style-type: none"> • Reset the unit by unplugging it for 30 seconds. • If the problem is not solved, there is a problem with the thermistor. The unit is still working, but will defrost frequently. Contact your installer.
6	The LED of the integrated control is blinking AMBER.	<ul style="list-style-type: none"> • Reset the unit by unplugging it for 30 seconds. • If the problem is not solved, there is a problem with the damper system. The unit is OFF. For a 5-hour period, the unit will try to reset the damper system every 30 minutes. After 5 hours, if the problem is not solved, the unit stops trying to reset the damper system. • Contact your installer.
7	The integrated control push-button does not work.	<ul style="list-style-type: none"> • The 30-second boot sequence is not completed, see step 2.1 Booting Sequence on page 4.

For optional wall controls problems, refer to the Troubleshooting section in the *Main and auxiliary wall controls user guide* (included with the ventilation unit).

If the problem is still not solved, contact your installer or the nearest approved Service Center.