

USER MANUAL

RESIDENTIAL USE ONLY



VB0298

HRV150FL AND HRV190FL

BROAN[®]

ABOUT THIS MANUAL / PRODUCT

The purpose of this manual is to help you with the use of your unit. Please read every section as they contain important information.

In simplifying explanations, all drawings (illustrations) in this manual show the unit installed in the “normal” position. However, please note that your unit can be installed in either the “normal” or “reverse” (upside down) position.

We welcome any suggestions you may have concerning this manual and/or the unit, and we would appreciate hearing your comments on ways to better serve you. Please forward all correspondence to us at the address indicated on the product’s registration card included with this manual.

This manual uses the following symbols to emphasize particular information:

⚠ WARNING

Identifies an instruction which, if not followed, might cause serious personal injuries including possibility of death.

CAUTION

Denotes an instruction which, if not followed, may severely damage the unit and/or its components.

NOTE: Indicates supplementary information needed to fully complete an instruction.

Finally, we want to congratulate you on your purchase of this excellent unit which will allow you and your family to enjoy fresh air throughout your home for years to come!

CAUTION

Some activities create dust or vapors which may damage your unit. You must therefore turn off and unplug your unit in the following situations:

- Major renovation work
- Sanding (e.g. gypsum joints, etc.)
- Housing construction
- Varnishing

During very heavy snowstorms or rain with strong winds, the unit should also be turned off to avoid problems caused by snow or rain entering the unit, even if it is equipped with an anti-gust intake hood.

CAUTION

When leaving the house for a long period of time (more than two weeks), a responsible person should regularly check if the unit operates adequately. If the ductwork runs through an unconditioned space (e.g.: attic), the unit must operate continuously except when performing maintenance and/or repair. Also, the ambient temperature of the house should never drop below 18°C (65°F). At least once a year, the unit mechanical and electronic parts should be inspected by qualified service personnel.

REPLACEMENT PARTS AND REPAIRS

In order to ensure your ventilation unit remains in good working condition, you must use Broan-NuTone LLC genuine replacement parts only. The Broan-NuTone LLC genuine replacement parts are specially designed for each unit and are manufactured to comply with all the applicable certification standards and maintain a high standard of safety. Any third party replacement part used may cause serious damage and drastically reduce the performance level of your unit, which will result in premature failing. Also, Broan-NuTone LLC recommends to contact a certified service depot for all replacement parts and repairs.

TABLE OF CONTENTS

1. YOUR UNIT AND ITS PURPOSE	4
1.2 PURPOSE OF THE VENTILATION SYSTEM	4
1.3 RECOVERY	5
1.4 DEFROST MODE	5
1.5 SPECIFICATIONS	5
2. CONTROLS.....	6
2.1 INTEGRATED CONTROL	6
2.2 BOOT SEQUENCE	6
2.3 OPTIONAL MAIN AND AUXILIARY CONTROLS.....	6
3. MAINTENANCE	7
3.1 EVERY THREE MONTHS.....	7
3.2 ANNUAL MAINTENANCE (FALL)	8
4. TROUBLESHOOTING.....	8

1. YOUR UNIT AND ITS PURPOSE

1.1 UNIT DESCRIPTION

1. Filters
2. Blower
3. Heat recovery core
4. Condensation tray

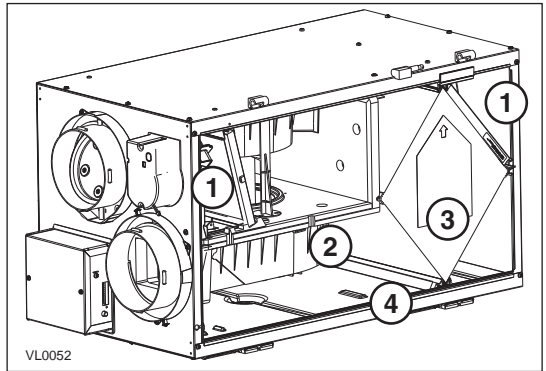

Unit shown in normal position. Can also be installed upside down.

1.2 PURPOSE OF THE VENTILATION SYSTEM

Your ventilation system is designed to provide fresh air, warmed outdoor air to your home while exhausting stale, humid air from your home. By eliminating accumulated pollutants and humidity, it maintains an optimum air quality and an ideal relative humidity.

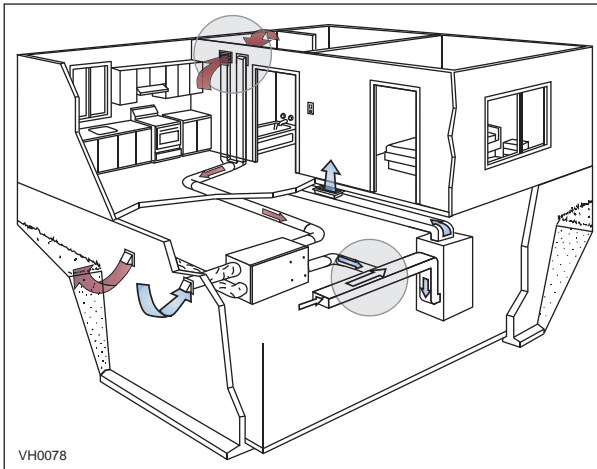

- NOTES:
1. Shown with a forced air system. Can also operate on its own.
 2. Installation may vary according to the model number and the position (normal or reverse) in which the unit is installed.

1. YOUR UNIT AND ITS PURPOSE (CONT'D)

1.3 RECOVERY

Your ventilation system is equipped with a heat recovery core that is designed specifically to control excess humidity and reduce ventilation costs by recovering the heat energy from the exhausted air, and using that same heat energy to warm the fresh air being supplied. This heat recovery process is accomplished in such a way that the stale air is never mixed with the fresh air.

EXAMPLE (IN WINTER)

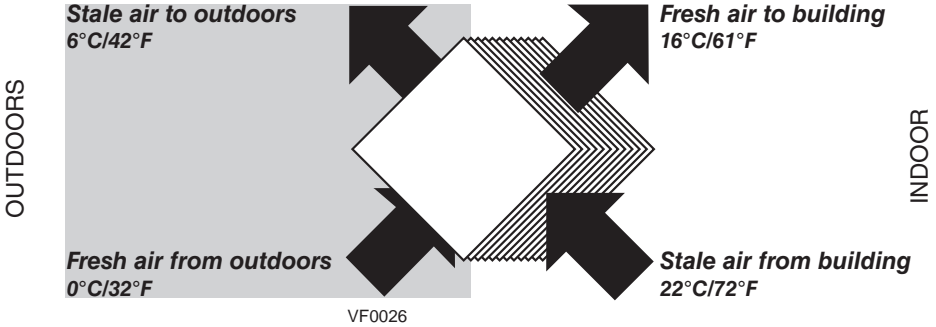

1.4 DEFROST MODE

When the outdoor temperature is below -5°C (23°F), heat recovery creates frost in the module. To maintain proper operation, the unit is programmed to defrost the recovery module. The defrost frequency varies according to the outdoor temperature. Defrost lasts 7 minutes (or 10 minutes if set on "Extended Defrost"). During the defrost cycle, the unit shifts to maximum speed and the dampers close.

After defrosting, the unit returns to the operating mode selected by the user.

1.5 SPECIFICATIONS

MODEL	HRV150FL	HRV190FL
WIDTH	30¼"	30¼"
HEIGHT	16½"	16½"
DEPTH	17⅛"	17⅛"
WEIGHT	65 LB. (29.5 KG)	65 LB. (29.5 KG)
ELECTRICAL SUPPLY	120 V, 60 Hz	120 V, 60 Hz
POWER CONSUMPTION	160 WATTS	195 WATTS

2. CONTROLS

2.1 INTEGRATED CONTROL

These units are equipped with an integrated control, located on the electrical compartment. Use the push-button (1) to control the unit. The LED (2) will then show on which mode the unit is in.

- NOTES:
1. The integrated control **must be turned OFF** to use an optional main control.
 2. If an optional auxiliary control is used, if activated, the auxiliary control operation will override the optional main control operation.

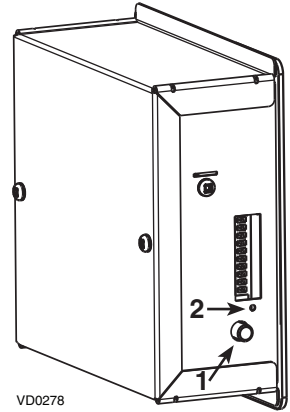

Refer to table below.

LED COLOR	RESULTS
AMBER	UNIT IS ON LOW SPEED.
GREEN	UNIT IS ON HIGH SPEED.
NO LIGHT	UNIT IS OFF OR CONTROLLED BY A MAIN CONTROL.



2.2 BOOT SEQUENCE

The unit boot sequence is similar to a personal computer boot sequence. Each time the unit is plugged after being unplugged, or after a power failure, the unit will perform a 30-second booting sequence before starting to operate. During the booting sequence, the integrated control LED will light GREEN or AMBER for 5 seconds, and then will shut off for 2 seconds. After that, the LED will light RED for the rest of the booting sequence. During this RED light phase, the unit is checking and resetting the motorized damper position. Once the motorized damper position is completely set, the RED light turns off and the booting sequence is done.

NOTE: No command will be taken until the unit is fully booted.

2.3 OPTIONAL MAIN AND AUXILIARY CONTROLS

For more convenience, these units can also be controlled using an optional main wall control. Many models can be used, but only one main wall control can be connected to the unit.

- NOTES:
1. The integrated control **must be turned OFF** to use an optional main control.
 2. If an optional auxiliary control is used, if activated, the auxiliary control operation will override the optional main control operation.

For more information about the available controls and their operation modes, refer to the *Main and auxiliary wall control User Guide*

3. MAINTENANCE

⚠ WARNING

Dangerous voltage may be present. During maintenance and repairs, the unit must always be turned off, and unplugged.

We take great care to minimize sharp edges; however, please proceed with caution when handling all components.

When cleaning the unit, it is recommended to wear safety glasses and gloves.

Regular maintenance should be performed every 3 months. Annual maintenance should take place every fall season.

NOTE: Unit is shown in normal position but can be installed in either the “normal” or “reverse” (upside down) position.

3.1 EVERY THREE MONTHS

1. Disconnect power supply.

2. Unlatch the door. Lift the panel towards you. Hold it firmly and hit on the right side of the panel. The door will slide to the left.

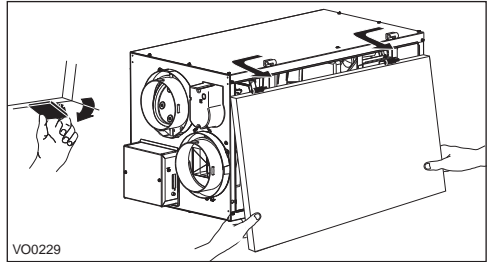

3. Clean the inside of the door with a damp cloth.

4. Clean filters:

- Remove filters.
- Vacuum to remove most of the dust.
- Wash with a mixture of warm water and mild soap. You may add bleach if you wish to disinfect (one tablespoon per gallon). Rinse thoroughly. Shake filters to remove excess water and let dry.

5. Clean the condensation tray with a damp cloth.

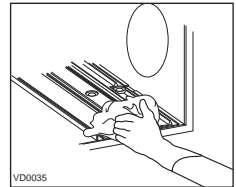

6. Check the exterior air intake hood:

- Make sure there are no leaves, twigs, ice or snow that could be drawn into the vent.
- Clean if necessary.

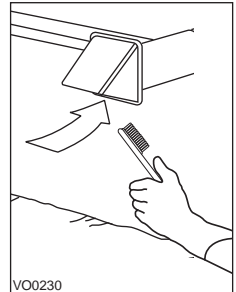

CAUTION

Even a partial blocking of this air vent could cause the unit to malfunction.

7. Reassemble the components.

8. Reconnect power supply.

3. MAINTENANCE (CONT'D)

3.2 ANNUAL MAINTENANCE (FALL)

Repeat steps 1 to 6 from the previous section and continue with the following steps:

CAUTION

Handle the heat recovery core with care.

1. Clean the heat recovery core:
 - Remove core.
 - Let it soak in a mixture of cold or lukewarm water and mild soap (dishwashing liquid).
 - Rinse thoroughly.
 - Shake the core to remove excess water and let it dry.
2. Clean blower assembly.
 - Remove dust using a vacuum cleaner with a soft brush attachment.
3. Reassemble the components.
4. Reconnect power supply.

4. TROUBLESHOOTING

PROBLEM	YOU SHOULD TRY THIS
1. Nothing works.	<ul style="list-style-type: none">• See if the unit is plugged in.• See if the unit is receiving power from the house circuit breaker or fuse.
2. Noisy unit.	<ul style="list-style-type: none">• Clean the unit (see Section 3). If the problem is not solved, contact your installer.
3. Condensation on windows (air too humid).	<ul style="list-style-type: none">• Operate the unit at maximum speed (MAX.) during activities generating excess humidity (family gatherings, extra cooking, etc.).• Leave curtains half-open to allow air circulation.• Store all firewood in a closed room with a dehumidifier or in a well ventilated room, or store the wood outdoors.• Keep the temperature in your house above 18°C (64°F).
4. Air too dry.	<ul style="list-style-type: none">• Operate the unit at low speed (MIN.).• Temporarily switch to the intermittent mode (if available).• Temporarily use a humidifier.
5. Air too cold at the air supply grille.	<ul style="list-style-type: none">• Make sure the outdoor hoods are not blocked.• Operate the unit at low speed (MIN.).• Have the system's balancing checked.• Have the unit's defrost system checked.• Install a duct heater.

For wall controls problems, refer to the Troubleshooting section in the *Main and auxiliary wall controls user guide*

If the problem is still not solved, contact your installer.

INSTALLER MANUAL



VB0298

HRV150FL
(PART HRV150FLS)
HRV190FL
(PART HRV190FLS)

RESIDENTIAL USE ONLY

READ AND SAVE THESE INSTRUCTIONS

ABOUT THIS MANUAL

Because of the large amount of models covered by this publication, the illustrations are typical ones. Some details of your unit may be slightly different than the ones shown.

Please take note that this manual uses the following symbols to emphasize particular information:

⚠ WARNING

Identifies an instruction which, if not followed, might cause serious personal injuries including possibility of death.

CAUTION

Denotes an instruction which, if not followed, may severely damage the unit and/or its components.

NOTE: Indicates supplementary information needed to fully complete an instruction.

We welcome any suggestions you may have concerning this manual and/or the unit, and we would appreciate hearing your comments on ways to better serve you.

ABOUT THESE UNITS

LIMITATION

For residential (domestic) installation only. Installation work and electrical wiring must be done by a qualified person(s) in accordance with all applicable codes and standards, including fire-rated construction codes and standards.

⚠ WARNING

TO REDUCE THE RISK OF FIRE, ELECTRIC SHOCK, OR INJURY TO PERSON(S) OBSERVE THE FOLLOWING:

1. Use this unit only in the manner intended by the manufacturer. If you have questions, contact the manufacturer at the address or telephone number listed in the warranty.
2. Before servicing or cleaning this unit, disconnect power cord from electrical outlet.
3. This unit is not designed to provide combustion and/or dilution air for fuel-burning appliances.
4. When cutting or drilling into the wall or ceiling, do not damage electrical wiring and other hidden utilities.
5. Do not use this unit with any solid-state speed control device other than following:

Units	Optional Main Controls	Optional Auxiliary Controls
HRV150FL	VT4W, VT6W, VT7W, AND VT8W	VB60W PUSH BUTTON, VB20W AND 59W
HRV190FL	VT4W, VT6W, VT7W, AND VT8W	VB60W PUSH BUTTON, VB20W AND 59W

6. This unit must be grounded. The power supply cord has a 3-prong grounding plug for your personal safety. It must be plugged into a mating 3-prong grounding receptacle, grounded in accordance with the national electrical code and local codes and ordinances. Do not remove the ground prong. Do not use an extension cord.
7. Do not install in a cooking area or connect directly to any appliances.
8. Do not use to exhaust hazardous or explosive materials and vapors.
9. When performing installation, servicing or cleaning this unit, it is recommended to wear safety glasses and gloves.
10. Due to the weight of the unit, two installers are recommended to perform installation.
11. When applicable local regulation comprise more restrictive installation and/or certification requirements, the aforementioned requirements prevail on those of this document and the installer agrees to conform to these at his own expenses.

CAUTION

1. To avoid prematurely clogged filters, turn the unit OFF during construction or renovation.
2. Please read specification label on product for further information and requirements.
3. Be sure to duct air outside – Do not intake/exhaust air into spaces within walls or ceiling or into attics, crawl spaces, or garage.
4. Intended for residential installation only in accordance with the requirements of NFPA 90B (for a unit installed in U.S.A.) or Part 9 of the National Building Code of Canada (for a unit installed in Canada).
5. Do not run any air ducts directly above or within 2 ft (0.61 m) of a furnace or its supply plenum, boiler, or other heat producing appliance. If a duct has to be connected to the furnace return plenum, it must be connected 10' (3.1 m) away from plenum's connection to the furnace.
6. The ductwork is intended to be installed in compliance with all applicable local and national codes.
7. When leaving the house for a long period of time (more than two weeks), a responsible person should regularly check if the unit operates adequately.
8. If the ductwork passes through an unconditioned space (e.g.: attic), the unit must operate continuously except when performing maintenance and/or repair. Also, the ambient temperature of the house should never drop below 18°C (65°F).

TABLE OF CONTENTS

1. TECHNICAL DATA	4
1.1 AIR DISTRIBUTION (NORMAL OPERATION)	4
1.2 AIR DISTRIBUTION (DEFROST MODE).....	4
1.3 DEFROST CYCLES TABLES.....	4
1.4 DIMENSIONS	5
1.5 SPECIFICATIONS	5
2. TYPICAL INSTALLATIONS	6
2.1 FULLY DUCTED SYSTEM	6
2.2 EXHAUST DUCTED SYSTEM (SOURCE POINT VENTILATION).....	6
2.3 SIMPLIFIED (VOLUME VENTILATION)	6
3. INSTALLATION	7
3.1 INSPECT THE CONTENT OF THE BOX	7
3.2 LOCATING AND MOUNTING THE UNIT	7
3.3 PLANNING OF THE DUCTWORK.....	7
3.4 CALCULATING THE DUCT SIZE.....	8
3.4.1 EXAMPLE OF CALCULATION.....	8
3.4.2 EXAMPLE OF A DESIGN FOR A FULLY DICTED SYSTEM FOR A UNIT HAVING A HIGH SPEED PERFORMANCE OF 222 CFM	8
3.5 INSTALLING THE DUCTWORK AND THE REGISTERS.....	9
3.5.1 FULLY DUCTED SYSTEM (AS ILLUSTRATED IN SECTION 2.1).....	9
3.5.2 EXHAUST DUCTED SYSTEM (AS ILLUSTRATED IN SECTION 2.2).....	9
3.5.3 SIMPLIFIED INSTALLATION (AS ILLUSTRATED IN SECTION 2.3)	10
3.6 CONNECTING THE DUCTS TO THE UNIT.....	11
3.7 INSTALLING THE EXTERIOR HOODS	12
3.8 CONNECTING THE DRAIN.....	12
4. CONTROLS	13
4.1 INTEGRATED CONTROL	13
4.1.1 BOOT SEQUENCE.....	13
4.1.2 SETTING EXTENDED DEFROST	13
4.2 ELECTRICAL CONNECTION TO OPTIONAL WALL CONTROL	14
4.2.1 ELECTRICAL CONNECTION TO VT8W MAIN WALL CONTROL	14
4.2.2 ELECTRICAL CONNECTION TO VT7W MAIN WALL CONTROL	14
4.2.3 ELECTRICAL CONNECTION TO VT4W MAIN WALL CONTROL	15
4.2.4 ELECTRICAL CONNECTION TO VT6W MAIN WALL CONTROL	15
4.2.5 ELECTRICAL CONNECTION TO OPTIONAL AUXILIARY WALL CONTROLS	15
5. ELECTRIC CONNECTION TO THE FURNACE	15
6. WIRING DIAGRAM	16
7. BALANCING THE UNIT	17
7.1 WHAT YOU NEED TO BALANCE THE UNIT	17
7.2 BEFORE YOU START	17
7.3 BALANCING PROCEDURE	17
8. SERVICE PARTS	18
9. TROUBLESHOOTING	19

1. TECHNICAL DATA

1.1 AIR DISTRIBUTION (NORMAL OPERATION)

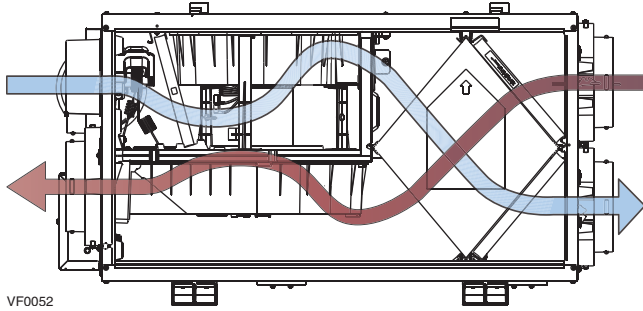

1.2 AIR DISTRIBUTION (DEFROST MODE)

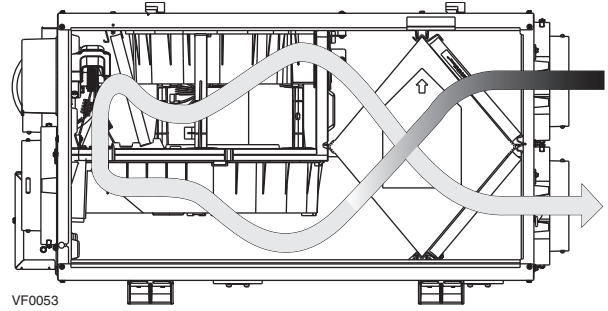

1.3 DEFROST CYCLES TABLES

HRV150FLS UNITS

OUTSIDE TEMPERATURE		DEFROST CYCLES (MINUTES)		EXTENDED DEFROST CYCLES	
CELCIUS (°C)	FAHRENHEIT (°F)	DEFROSTING	OPERATION TIME BETWEEN EACH DEFROST CYCLES	DEFROSTING	OPERATION TIME BETWEEN EACH DEFROST CYCLES
-5	23	7	50	10	30
-15	5	7	25	10	20
-27	-17	10	20	10	15

HRV190FLS UNITS

OUTSIDE TEMPERATURE		DEFROST CYCLES (MINUTES)		EXTENDED DEFROST CYCLES	
CELCIUS (°C)	FAHRENHEIT (°F)	DEFROSTING	OPERATION TIME BETWEEN EACH DEFROST CYCLES	DEFROSTING	OPERATION TIME BETWEEN EACH DEFROST CYCLES
-5	23	6	50	10	30
-15	5	6	25	10	20
-27	-17	10	20	10	15

NOTE: The Performance Charts are listed on the specification sheets of these units.

1. TECHNICAL DATA (CONT'D)

1.4 DIMENSIONS

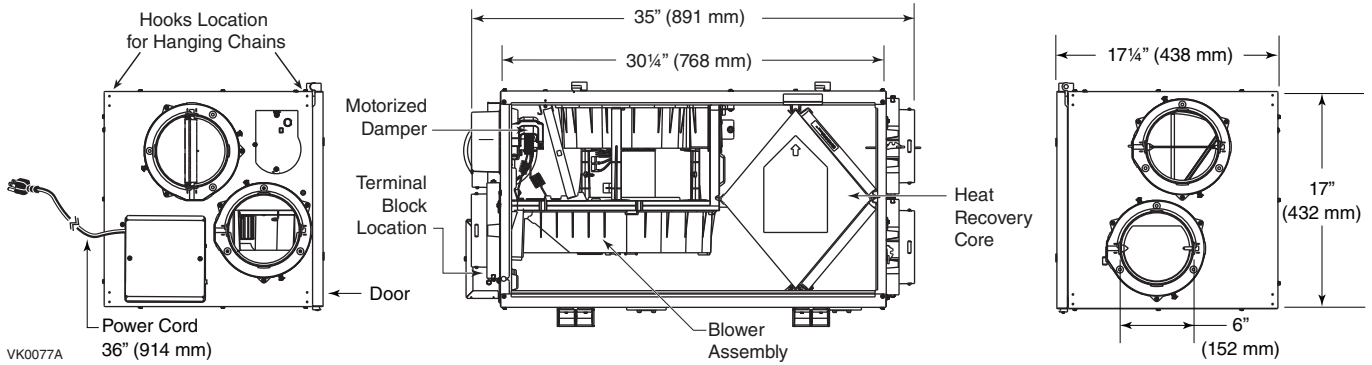

1.5 SPECIFICATIONS

MODEL	HRV150FLS	HRV190FLS
WEIGHT	65 LB. (29.5 kg)	65 LB. (29.5 kg)
PORT DIAMETER	6" (152 mm)	6" (152 mm)
DRAIN DIAMETER	1/2" (12 mm)	1/2" (12 mm)
INSTALLATION	CHAINS AND SPRINGS (PROVIDED WITH THE UNIT)	
MOTOR SPEED	HIGH AND LOW SPEED FACTORY SET (OPTIONAL INCREASED LOW SPEED)	
ELECTRICAL SUPPLY	120 V, 60 Hz	120 V, 60 Hz
POWER CONSUMPTION	160 WATTS	195 WATTS

2. TYPICAL INSTALLATIONS

NOTE: Installation may vary according to the model number and the position (normal or reverse) in which the unit is installed.

There are three common installation methods.

2.1 FULLY DUCTED SYSTEM

(Primarily for homes with radiant hot water or electric baseboard heating. See illustration at right.)

Moist, stale air is exhausted from the high humidity areas in the home, such as bathrooms, kitchen and laundry room.

Fresh air is supplied to bedrooms and principal living areas.

If required, bathroom fans and a range hood may be used to better exhaust stale air.

Homes with more than one level require at least one exhaust register at the highest level.

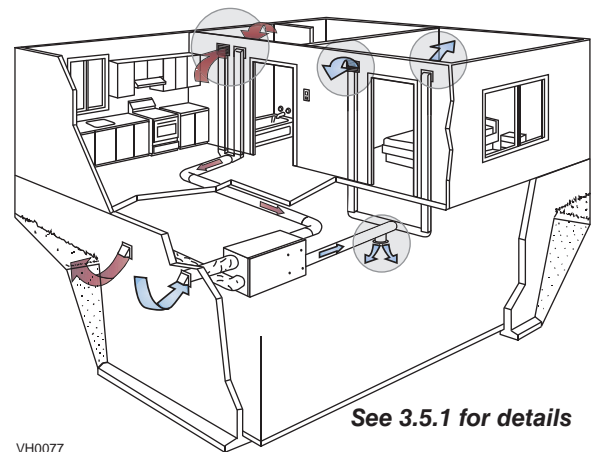

2.2 EXHAUST DUCTED SYSTEM (SOURCE POINT VENTILATION)

(For homes with forced air heating. See illustration at right.)

Moist, stale air is exhausted from the high humidity areas in the home, such as bathrooms, kitchen and laundry room. Fresh air is supplied to the cold air return or the supply duct of the furnace. If required, bathroom fans and a range hood may be used to better exhaust stale air.

Homes with more than one level require at least one exhaust register at the highest level.

NOTE: For this type of installation, it is not essential that the furnace blower runs when the unit is in operation, but we recommend it.

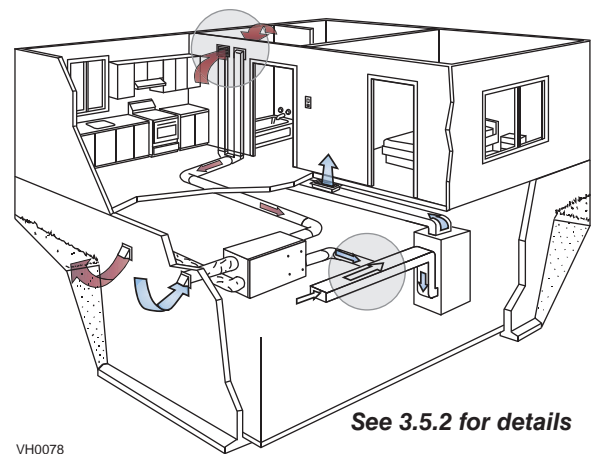

2.3 SIMPLIFIED (VOLUME VENTILATION)

(For homes with forced air heating. See illustration at right.)

Fresh air and exhaust air flow through the furnace ducts, which simplifies the installation.

The use of bathroom fans and a range hood is suggested to exhaust stale air.

NOTE: For this type of installation, the **furnace blower must be running** when the unit is in operation.

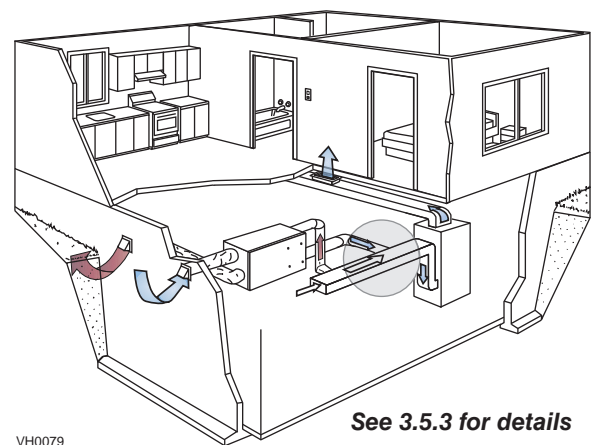

3. INSTALLATION

⚠ WARNING

When applicable local regulation comprises more restrictive installation and/or certification requirements, the aforementioned requirements prevail on those of this document and the installer agrees to conform to these at his own expenses.

⚠ WARNING

When performing installation, servicing or cleaning the unit, it is recommended to wear safety glasses and gloves.

3.1 INSPECT THE CONTENT OF THE BOX

- Inspect the exterior of the unit for shipping damage. Make sure that there is no damage to the door, door latches, door hinges, dampers, duct collars, cabinet, etc.
- Inspect the interior of the unit for damage. Make sure that the fan motor assembly, recovery module, insulation, dampers, condensation tray are all intact.
- If the unit was damaged during shipping, contact your local distributor. (Claim must be made within 24 hours after delivery.)

NOTE: Before installing the unit, remove its shipping bracket by removing its wing nut and loosening both its retaining screws.

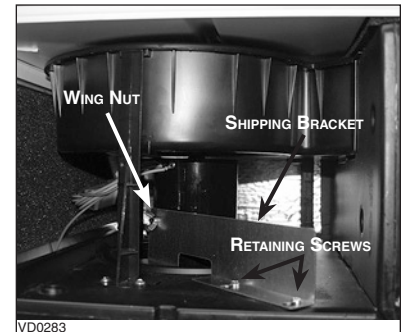

3.2 LOCATING AND MOUNTING THE UNIT

NOTE: Please note that these units can be installed in either the normal or reverse (upside down) position.

CAUTION

When installed in reverse position (upside down) in a cold region where outside temperature could drop below -20°C (-4°F) for more than 5 days in a row, the unit must always be set in extended defrost. See Section 4.1.2 Setting Extended Defrost.

Choose an **appropriate location** for the unit:

- Within an area of the house where the **ambient temperature is kept between 10°C (50°F) and 40°C (104°F)**
- Away from living areas (dining room, living room, bedroom), if possible
- So as to provide easy access to the interior cabinet for every three months and annual maintenance, and to the control panel on the side of the unit;
- Close to an exterior wall, so as to limit the length of the insulated flexible duct to and from the unit
- Close to a drain. If no drain is close by, use a pail to collect run-off
- Away from hot chimneys, electrical panel and other fire hazards
- Allow for a power source (standard outlet)

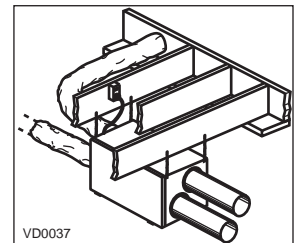

Hang the unit with the 4 chains and springs provided (see illustrations at right).

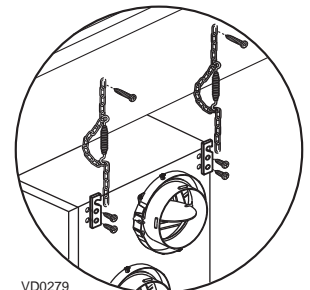

3.3 PLANNING OF THE DUCTWORK

- Follow the instructions in Section 3.4 (next page) to determine the appropriate duct diameters for your system.
- Keep it simple. Plan for a minimum number of bends and joints. Keep the length of insulated duct to a minimum.
- Do not use wall cavities as ducts. Do not use branch lines smaller than $4'' \text{ } \varnothing$ ($102 \text{ mm } \varnothing$).
- Do not ventilate crawl spaces or cold rooms. Do not attempt to recover the exhaust air from a dryer or a range hood. This would cause clogging of the recovery module. Use sheet metal for the kitchen exhaust duct.
- Be sure to plan for at least one exhaust register on the highest lived-in level of the house if it has 2 floors or more.

3. INSTALLATION (CONT'D)

3.4 CALCULATING THE DUCT SIZE

Use the table below to ensure that the ducts you intend to install will be carrying air flows at or under the recommended values. Avoid installing ducts that will have to carry air flows near the maximum values and never install a duct if its air flow exceeds the maximum value.

DUCT DIAMETER	RECOMMENDED AIR FLOW			MAXIMUM AIR FLOW		
	CFM	L/S	M ³ /H	CFM	L/S	M ³ /H
4" (102 MM)	40 CFM	19 L/s	68 M ³ /H	60 CFM	28 L/s	102 M ³ /H
5" (127 MM)	75 CFM	35 L/s	127 M ³ /H	110 CFM	52 L/s	187 M ³ /H
6" (152 MM)	120 CFM	57 L/s	204 M ³ /H	180 CFM	85 L/s	306 M ³ /H
7" (178 MM)	185 CFM	87 L/s	314 M ³ /H	270 CFM	127 L/s	459 M ³ /H
8" (203 MM)	260 CFM	123 L/s	442 M ³ /H	380 CFM	179 L/s	645 M ³ /H

NOTE: Examples 3.4.1 and 3.4.2 use imperial measures. The same calculation applies to metric measures.

3.4.1 EXAMPLE OF CALCULATION

PROBLEM: My installation requires two exhaust registers (one for the kitchen, one for the bathroom). I will connect these registers to a main duct which will connect to the unit (high speed performance value of 140 cfm). What size of duct should I use for the main exhaust duct and for the two end branches leading to the registers? (See illustration at right.)

SOLUTION: Simplified method. (For a more detailed method of calculating duct size, refer to the ASHRAE or HRAI HANDBOOK).

Main duct: Table above indicates a 6" Ø duct: Recommended air flow: 120 cfm; maximum air flow: 180 cfm. The high speed air flow of 140 cfm is close enough to the recommended value (120) and far away enough from the maximum value (180). Therefore a 6" Ø duct or larger is an appropriate choice for the main exhaust duct.

End branches: Each end branch will have to transport an air flow of 70 cfm (140 divided by 2). Table above indicates a 5" Ø duct: Recommended air flow: 75 cfm; maximum air flow: 110 cfm. The high speed air flow of 70 cfm is close enough to the recommended value (75) and far enough away from the maximum value (110). Therefore a 5" Ø duct or larger is an appropriate choice for the 2 end branches.

NOTE: A 4" Ø duct would have been too small because the maximum acceptable value for a 4" Ø duct is 60 cfm.

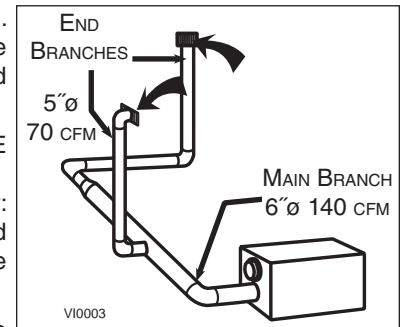

3.4.2 EXAMPLE OF A DESIGN FOR A FULLY DUCTED SYSTEM FOR A UNIT HAVING A HIGH SPEED PERFORMANCE OF 222 CFM

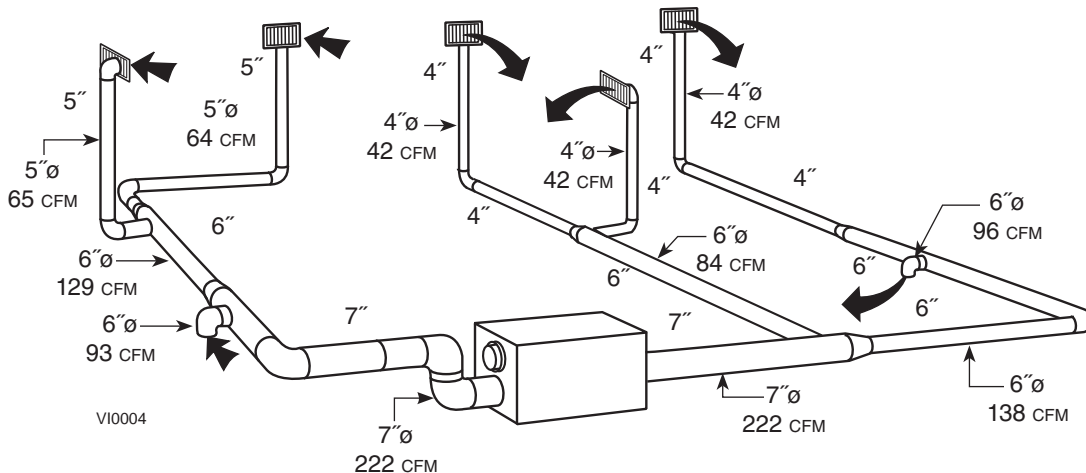

3. INSTALLATION

3.5 INSTALLING THE DUCTWORK AND THE REGISTERS

⚠ WARNING

Never install a stale air exhaust register in a room where there is a combustion device, such as a gas furnace, a gas water heater or a fireplace.

CAUTION

The ductwork is intended to be installed in compliance with all local and national codes that are applicable.

3.5.1 FULLY DUCTED SYSTEM (AS ILLUSTRATED IN SECTION 2.1)

STALE AIR EXHAUST DUCTWORK:

- Install registers in areas where contaminants are produced: kitchen, bathrooms, laundry room, etc.
- Install registers on an interior wall, 6 to 12 inches (152 to 305 mm) away from the ceiling OR in the ceiling.
- Install the kitchen register at least 4 feet (1.2 m) away from the range.
- If possible, measure the velocity of the air flowing through the registers. If the velocity is higher than 400 ft/min. (122 m/min), then the register type is too small. Replace with a larger one.

FRESH AIR DISTRIBUTION DUCTWORK:

- Install registers in bedrooms, dining room, living room and basement.
- Install registers either in the ceiling or high on the walls with air flow directed towards the ceiling.
(The cooler air will then cross the upper part of the room, and mix with room air before descending to occupant level.)
- If a register must be floor installed, direct the air flow up the wall.

3.5.2 EXHAUST DUCTED SYSTEM (AS ILLUSTRATED IN SECTION 2.2)

STALE AIR EXHAUST DUCTWORK:

Same as for Fully Ducted System, described on point 3.5.1 above)

FRESH AIR DISTRIBUTION:

⚠ WARNING

When performing duct connection to the furnace, installation must be done in accordance with all applicable codes and standards. Please refer to your local building code.

CAUTION

When performing duct connection to the furnace supply duct, use a metal duct appropriately sized to support the additional airflow produced by the HRV. It is recommended that the HRV is running when the furnace is in operation in order to prevent backdrafting inside HRV.

There are two methods for connecting the unit to the furnace:

METHOD 1: SUPPLY SIDE CONNECTION

- Cut an opening into the furnace supply duct at least 18 inches (0.5 m) away from the furnace.
- Connect this opening to the fresh air distribution port of the HRV (use metal duct, see illustration at right).
- Make sure that the HRV duct forms an elbow inside the furnace ductwork.
- If desired, interlock (synchronize) the furnace blower operation with the HRV. (See Section 5).

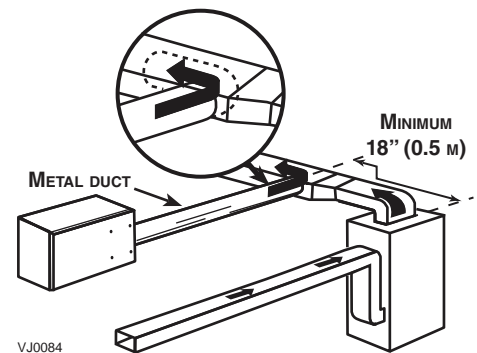

METHOD 2: RETURN SIDE CONNECTION

- Cut an opening into the furnace return duct not less than 10 feet (3.1 m) away from the furnace (A+B).
- Connect this opening to the fresh air distribution port of the HRV (see illustration at right).

NOTE: For Method 2, It is recommended, but not essential that the furnace blower runs when the unit is in operation. If desired, synchronize the furnace blower operation with the HRV. (See Section 5).

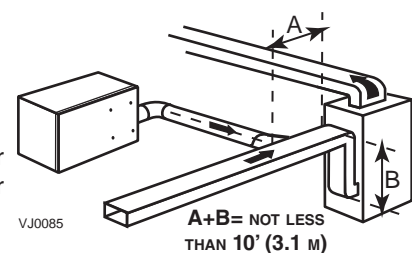

3. INSTALLATION (CONT'D)

3.5 INSTALLING THE DUCTWORK AND THE REGISTERS (CONT'D)

3.5.3 SIMPLIFIED INSTALLATION (AS ILLUSTRATED IN SECTION 2.3)

⚠ WARNING

When performing duct connection to the furnace, installation must be done in accordance with all applicable codes and standards. Please refer to your local building code.

CAUTION

When performing duct connection to the furnace ducts (Method 1), use metal ducts appropriately sized to support the additional airflow produced by the HRV. It is recommended that the HRV is running when the furnace is in operation in order to prevent backdrafting inside HRV.

There are two ways (illustrated below) of connecting the unit to the furnace ducts:

METHOD 1: RETURN-SUPPLY

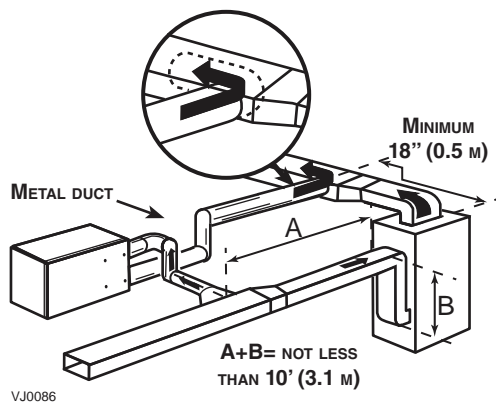

METHOD 2: RETURN-RETURN

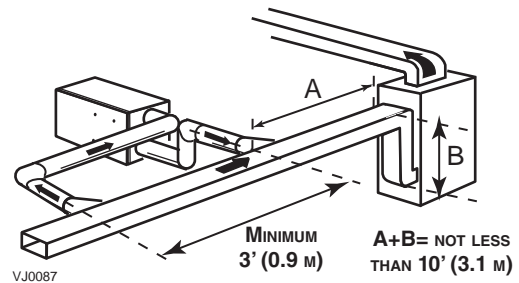

STALE AIR INTAKE:

- Cut an opening into the furnace return duct not less than 10 feet (3.1 m) from the furnace.
- Connect this opening to the stale air intake port of the HRV (as shown above).

FRESH AIR DISTRIBUTION:

Same instructions as for Method 1 or Method 2, section 3.5.2 in previous page.

CAUTION

If using Method 2, make sure the furnace blower is synchronized with the unit operation! See Section 5.

For Method 2 (Return-Return), make sure there is a distance of at least 3 feet (0.9 m) between the 2 connections to the furnace duct.

NOTE: For Method 1, it is recommended, but not essential to synchronize the furnace blower operation with the HRV operation.

3. INSTALLATION (CONT'D)

3.6 CONNECTING THE DUCTS TO THE UNIT

CAUTION

If ducts have to go through an unconditioned space (e.g.: attic), always use insulated ducts.

INSULATED FLEXIBLE DUCTS

Use the following procedure to connect the insulated flexible duct to the ports (exhaust to outside and fresh air from outside).

- ① Pull back the insulation to expose the flexible duct and place it **over inner port ring**.
- ② Install good quality **aluminum duct tape** on flexible duct to prevent potential water leakage from duct.
- ③ Attach the flexible duct to the port using tie wrap.
- ④ Pull the insulation over the joint and tuck it **between the inner and outer rings** of the double collar.
- ⑤ Pull down the vapor barrier (shaded part in illustrations below) **over the outer ring** to cover it completely. Fasten the vapor barrier in place using the port strap (included in parts bag). To do so, insert one collar pin through vapor barrier and first strap hole, then insert the other collar pin through vapor barrier and center strap hole and close the loop by inserting the first collar pin in the last strap hole.

CAUTION

Make sure that the vapor barrier on the insulated ducts does not tear during installation to avoid condensation within the ducts.

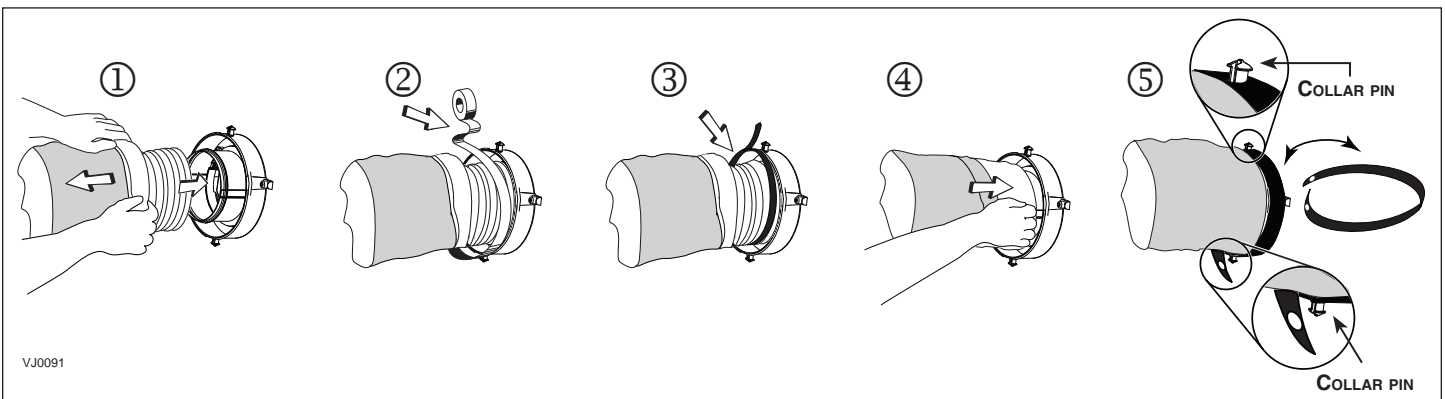

RIGID DUCTS

To prevent potential water leakage from ducts, use good quality aluminum duct tape to connect the rigid ducts to the ports.

CAUTION

Do not use screws to connect rigid ducts to the ports.

Make sure that both balancing dampers are left in a fully open position before connecting the **Fresh air to building port** and **Exhaust air from building port** (as shown in illustration at right).

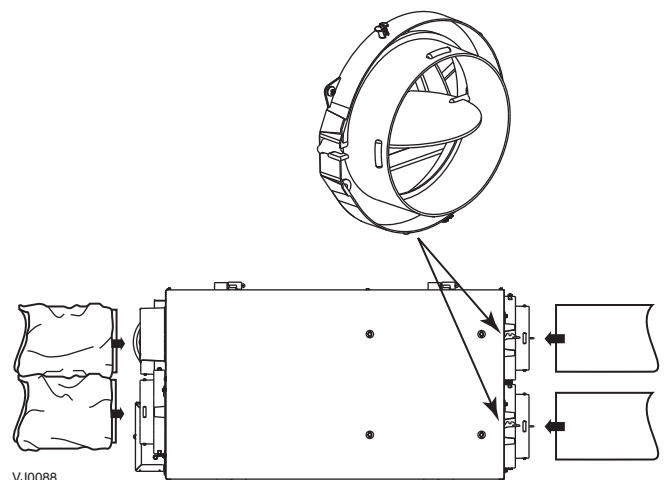

3. INSTALLATION (CONT'D)

3.7 INSTALLING THE EXTERIOR HOODS

Choose an appropriate location for the exterior hoods:

- At least 6 feet (1.8 m) away from each other to avoid cross-contamination
- At least 18 inches (457 mm) above the ground

⚠ WARNING

Make sure the intake hood is at least 6 feet (1.8 m) away from any of the following:

- Dryer exhaust, high efficiency furnace vent, central vacuum vent
- Gas meter exhaust, gas barbecue-grill
- Any exhaust from a combustion source
- Garbage bin and any other source of contamination.

Refer to illustration at right to connect the insulated duct to the hoods. An "Anti-Gust Intake Hood" should be installed in regions where a lot of snow is expected to fall.

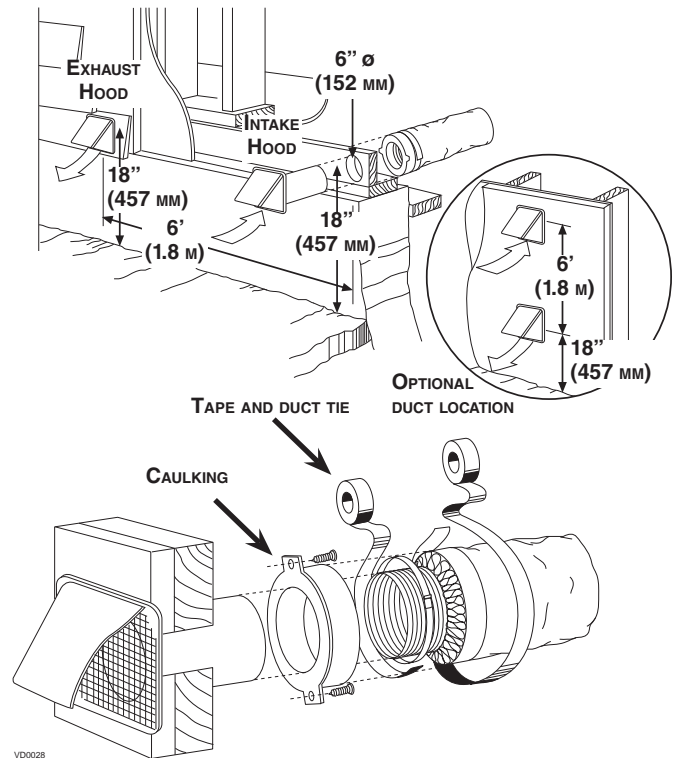

3.8 CONNECTING THE DRAIN

CAUTION

A drain tubing (included) must be installed for all units.

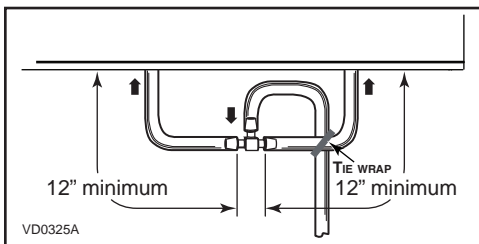

Cut 2 sections of plastic tube, at least 12"-long each, and attach them to each inner drain fitting, located under the unit.

Join both short sections to the "T" junction and main tube as shown, to prevent the unit from drawing unpleasant odors from the drain.

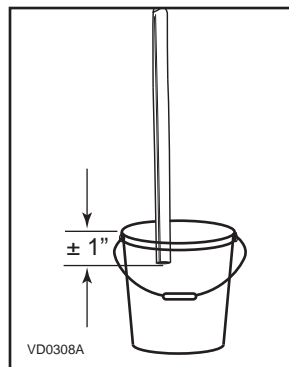

Run the tube to the floor drain or to an alternative drain pipe or pail.

IMPORTANT: If using a pail to collect water, locate the tube end approximately 1" from the top of the pail in order to prevent water from being drawn back up into the unit.

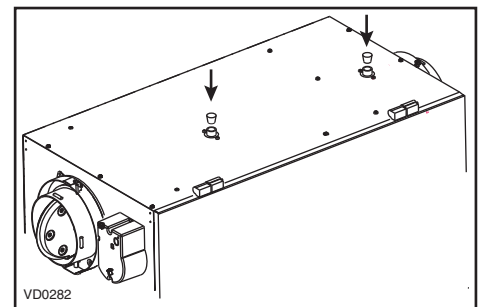

Insert both drain plugs (included in parts bag) in alternate drain fittings located on top of the unit.

4. CONTROLS

4.1 INTEGRATED CONTROL

All units are equipped with an integrated control, located in front of the electrical compartment. Use the push button (1) to control the unit. The LED (2) will then show what mode the unit is in.

NOTES: 1. The integrated control **must be turned OFF** to use an optional main control.

2. If an optional auxiliary control is used, when activated, it overrides the optional main control.

Refer to table below to see how to operate the unit using its integrated control.

PRESS ON PUSH BUTTON	LED COLOR	RESULTS
ONCE	AMBER	UNIT IS ON LOW SPEED
TWICE	GREEN	UNIT IS ON HIGH SPEED
THREE TIMES	NO LIGHT	UNIT IS OFF

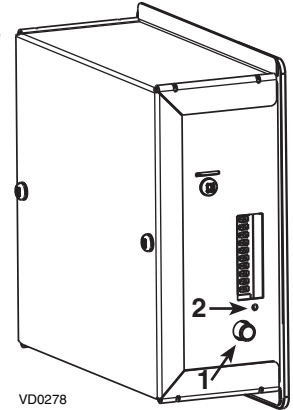

VD0278

If a problem occurs during the unit operation, its integrated control LED (2) will blink. The color of the blinking light depends on the type of error detected. Refer to Section 9 Troubleshooting on pages 19 and 20 for further details.

4.1.1 BOOT SEQUENCE

The unit boot sequence is similar to a personal computer boot sequence. Each time the unit is plugged after being unplugged, or after a power failure, the unit will perform a 30-second booting sequence before starting to operate. During the booting sequence, the integrated control LED will light GREEN (unit set in normal defrost) or AMBER (unit set in extended defrost) for 5 seconds, and then will shut off for 2 seconds. After that, the LED will light RED for the rest of the booting sequence. During this RED light phase, the unit is checking and resetting the motorized damper position. Once the motorized damper position completely set, the RED light turns off and the booting sequence is done.

NOTE: No command will be taken until the unit is fully booted.

4.1.2 SETTING EXTENDED DEFROST

The unit is factory set to normal defrost. In cold areas, it may be necessary to setup extended defrost. During the first 5 seconds of booting sequence, while the integrated control LED is GREEN, press on push-button until the LED turns AMBER (about 3 seconds).



VD0281

CAUTION

When installed in reverse position (upside down) in a cold region where outside temperature could drop below -20°C (-4°F) for more than 5 days in a row, the unit must always be set in extended defrost.

4. CONTROLS (CONT'D)

4.2 ELECTRICAL CONNECTION TO OPTIONAL WALL CONTROL

For more convenience, this unit can also be controlled using an optional main wall control.

⚠ WARNING

Always disconnect the unit before making any connections. Failure in disconnecting power could result in electrical shock or damage of the wall control or electronic module inside the unit.

CAUTION

Never install more than one optional main wall control per unit. Make sure that the wires do not short-circuit between themselves or by touching any other components on the wall control. Avoid poor wiring connections. To reduce electrical interference (noise) potential, do not run wall control wiring next to control contactors or near light dimming circuits, electrical motors, dwelling/building power or lighting wiring, or power distribution panel.

Use the terminal connector included in the installation kit to perform the electrical connection for main and optional wall controls. Check if all wires are correctly inserted in their corresponding holes in the terminal block. (A wire is correctly inserted when its orange receptacle is lower than another one without wire. On illustration at right, wire **A** is correctly inserted, but not wire **B**.)

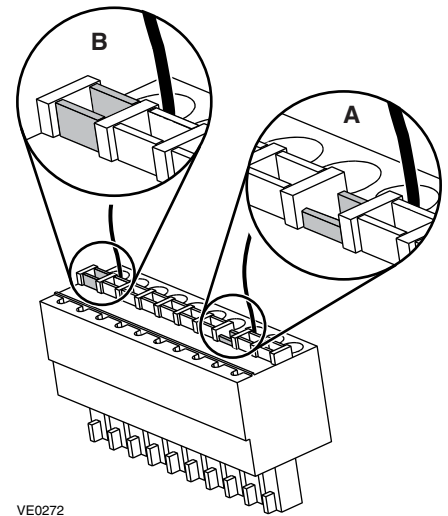

VE0272

Once the wall control(s) connections have been made, insert the terminal connector in the electrical compartment front face.

NOTE: For information about the operation of the wall controls, refer to the user guide.

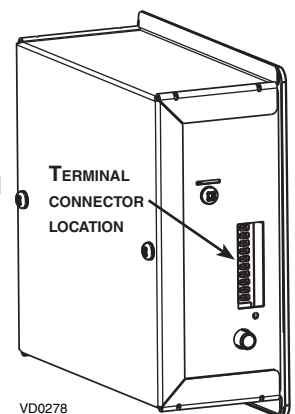

VD0278

4.2.1 ELECTRICAL CONNECTION TO VT8W MAIN WALL CONTROL

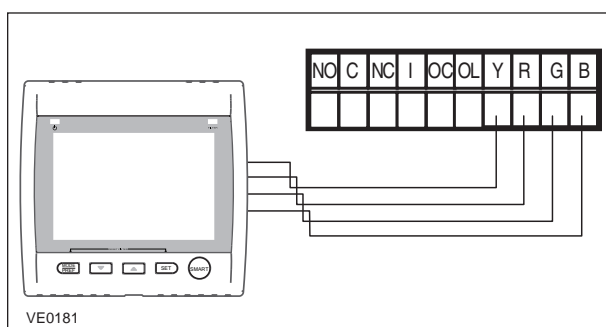

VE0181

4.2.2 ELECTRICAL CONNECTION TO VT7W MAIN WALL CONTROL

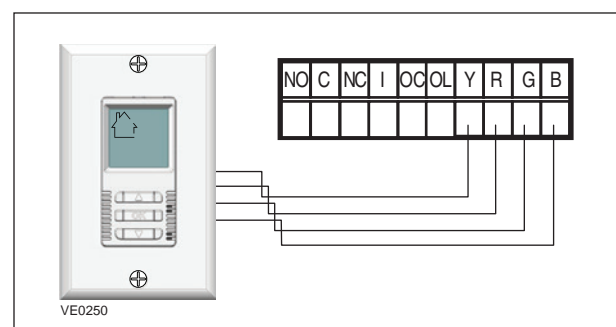

VE0250

4. CONTROLS (CONT'D)

4.2 ELECTRICAL CONNECTION TO OPTIONAL WALL CONTROL (CONT'D)

4.2.3 ELECTRICAL CONNECTION TO VT4W MAIN WALL CONTROL

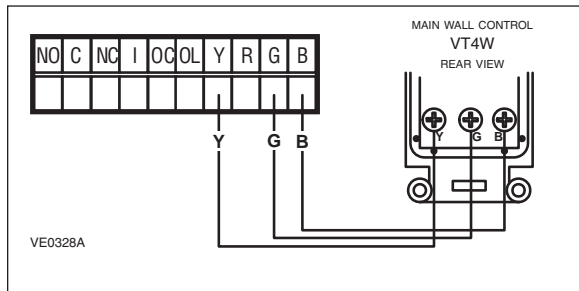

4.2.4 ELECTRICAL CONNECTION TO VT6W MAIN WALL CONTROL

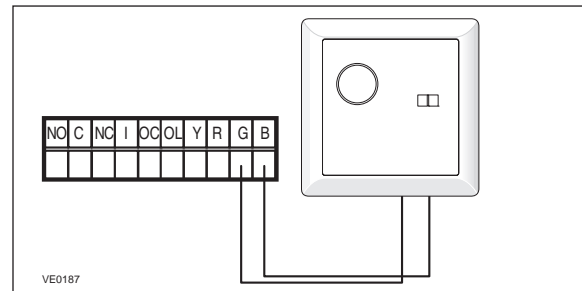

4.2.5 ELECTRICAL CONNECTION TO OPTIONAL AUXILIARY WALL CONTROLS

NOTE: If an auxiliary wall control is first activated, and the Dehumidistat is activated afterwards, the operation of the latter will override the operation of the first.

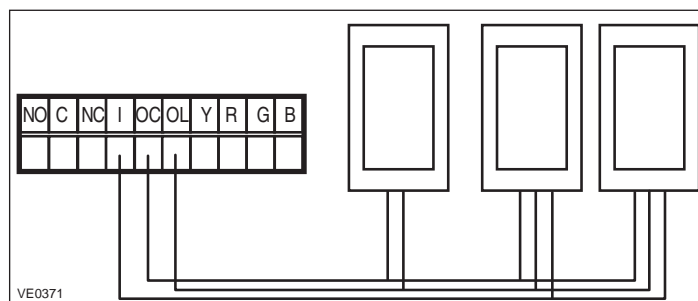

5. ELECTRIC CONNECTION TO THE FURNACE

⚠ WARNING

Never connect a 120-volt AC circuit to the terminals of the furnace interlock (standard wiring). Only use the low voltage class 2 circuit of the furnace blower control.

FOR A FURNACE CONNECTED TO A COOLING SYSTEM:

On some older thermostats, energizing the "R" and "G" terminals at the furnace has the effect of energizing "Y" at the thermostat and thereby turning on the cooling system. If you identify this type of thermostat, you must use the ALTERNATE FURNACE INTERLOCK WIRING.

STANDARD FURNACE INTERLOCK WIRING

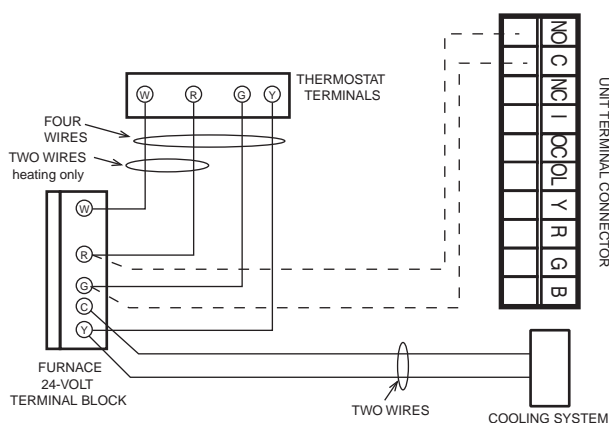

ALTERNATE FURNACE INTERLOCK WIRING

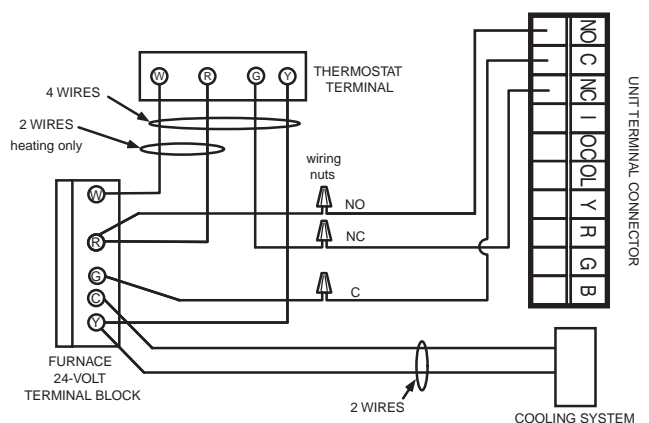

6. WIRING DIAGRAM

⚠ WARNING

- Risk of electric shocks. Before performing any maintenance or servicing, always disconnect the unit from its power source.
- This product is equipped with an overload protection (fuse). A blown fuse indicates an overload or a short-circuit situation. If the fuse blows, unplug the product from the outlet. Discontinue using the unit and contact technical support.

LOGIC DIAGRAM

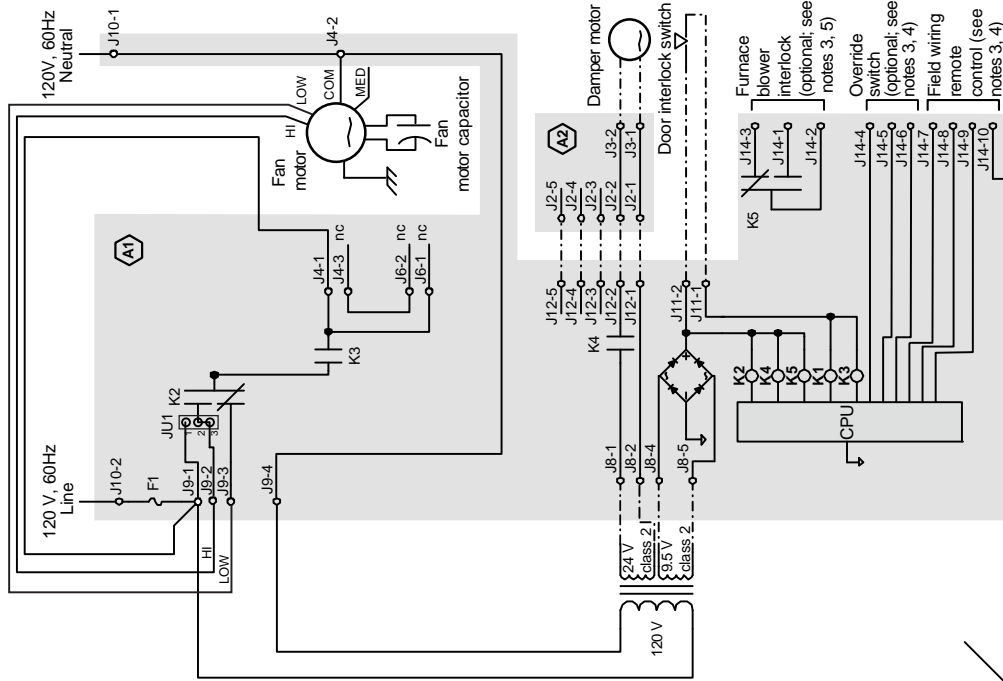

WIRING DIAGRAM

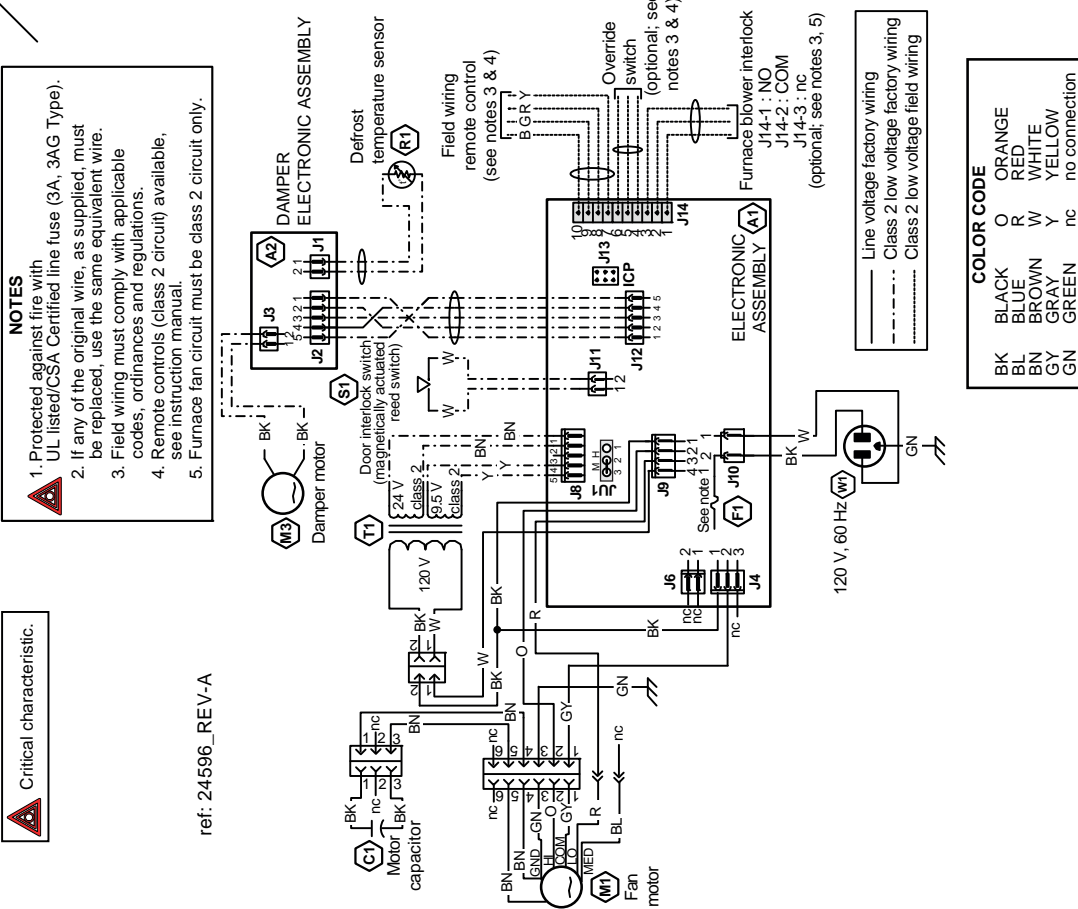

- NOTES**
1. Protected against fire with UL listed/CSA Certified line fuse (3A, 3AG Type).
 2. If any of the original wire, as supplied, must be replaced, use the same equivalent wire.
 3. Field wiring must comply with applicable codes, ordinances and regulations.
 4. Remote controls (Class 2 circuit) available, see instruction manual.
 5. Furnace fan circuit must be class 2 circuit only.

⚠ Critical characteristic.

ref: 24596_REV-A

Line voltage factory wiring
 Class 2 low voltage factory wiring
 Class 2 low voltage field wiring

COLOR CODE

BK	BLACK	O	ORANGE
BL	BLUE	R	RED
BN	BROWN	W	WHITE
GY	GRAY	Y	YELLOW
GN	GREEN	nc	no connection

7. BALANCING THE UNIT

7.1 WHAT YOU NEED TO BALANCE THE UNIT

- A magnehelic gauge capable of measuring 0 to 0.5 inch of water (0 to 125 Pa) and 2 plastic tubes.
- The balancing chart of the unit.

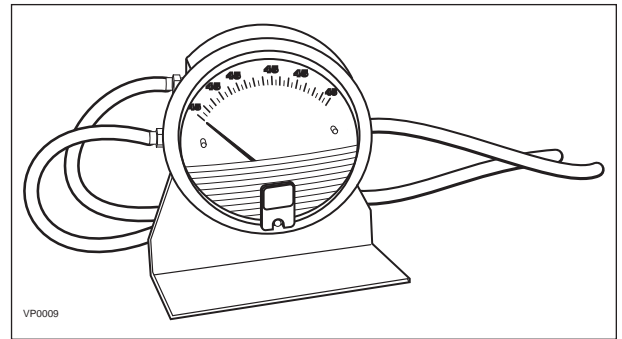

7.2 BEFORE YOU START

- Seal all the unit ductwork with tape. Close all windows and doors.
- Turn off all exhaust devices such as range hood, dryer and bathroom fans.
- Make sure the integrated balancing dampers are fully open.
- Make sure all filters are clean (if it is not the first time the unit is balanced).

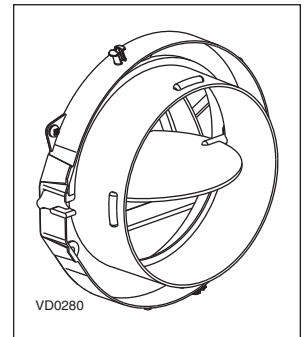

7.3 BALANCING PROCEDURE

1. Set the unit to high speed.

Make sure that the furnace/air handler blower is ON if the installation is in any way connected to the ductwork of the cold air return. If not, leave furnace/air handler blower OFF. If the outside temperature is below 0°C/32°F, make sure the unit is not running in defrost while balancing. (By waiting 10 minutes after plugging the unit in, you are assured that the unit is not in a defrost cycle.)

2. Place the magnehelic gauge on a level surface and adjust it to zero.

3. Connect tubing from gauge to EXHAUST air flow pressure taps (see diagram at right). Be sure to connect the tubes to their appropriate high/low fittings. If the gauge drops below zero, reverse the tubing connections.

NOTE: It is suggested to start with the exhaust air flow reading because the exhaust has typically more restriction than the fresh air, especially in cases of fully ducted installations or source point ventilation.

Place the magnehelic gauge upright and level. Record equivalent AIR FLOW of the reading according to the balancing chart.

4. Move tubing to FRESH air flow pressure taps (see diagram). Adjust the fresh air balancing damper until the FRESH air flow is approximately the same as the EXHAUST air flow. If FRESH air flow is less than EXHAUST air flow, then go back and adjust the exhaust balancing damper to equal the FRESH air flow.

5. Secure both dampers in place with a fastening screw.

6. Write the required air flow information on a label and stick it near the unit for future reference (date, maximum speed air flows, your name, phone number and business address).

7. Install 4 pressure taps plugs (included in parts bag).

NOTES: 1. Use conversion chart provided with the unit to convert magnehelic gauge readings to equivalent cfm values.

2. The unit is considered balanced even if there is a difference of ± 10 cfm (or ± 5 l/s or 17 m³/h) between the two air flows.

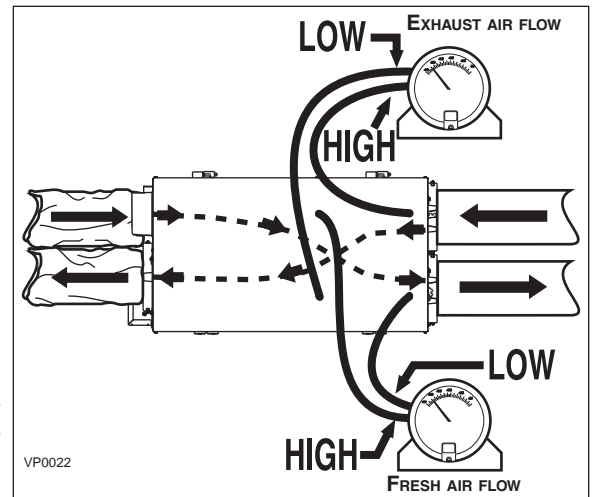

8. SERVICE PARTS

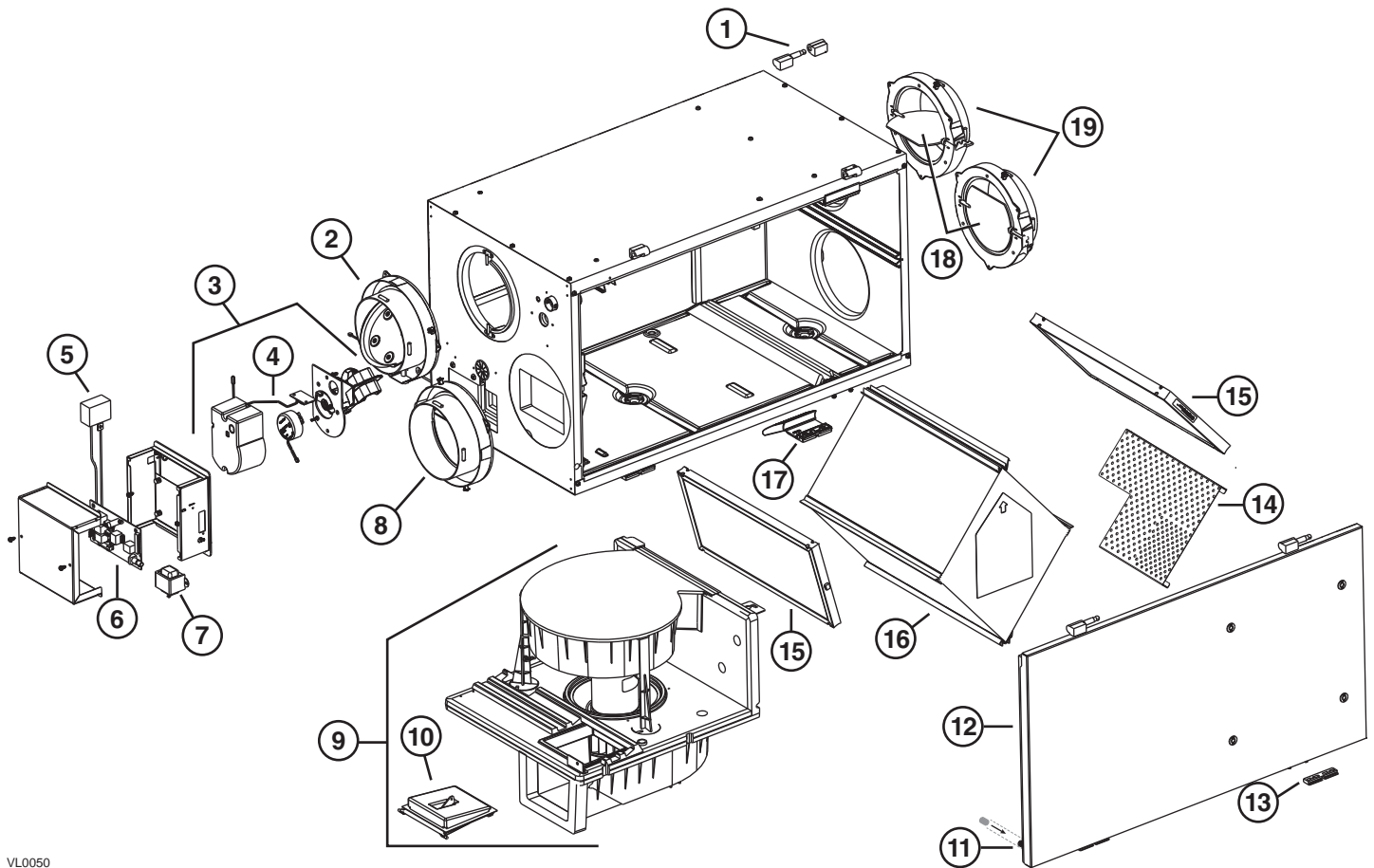

VL0050

ITEM	DESCRIPTION	HRV150FL	HRV190FL
1	Hinge assembly kit	SV13036	SV13036
2	Damper supply port assembly	SV17245	SV17245
3	Damper system actuator (including no. 4)	SV17235	SV17235
4	Thermistor kit	SV17242	SV17242
5	Capacitor 7.5 μ F	SV17240	SV17240
6	Electronic board	SV60810	SV60810
7	Transformer	SV17244	SV17244
8	Double collar port	SV60818	SV60818
9	Blower assembly (including no. 10)	SV60804	SV60805
10	Square damper kit	SV17243	SV17243
11	Magnet switch	SV19060	SV19060
12	Door assembly (including hinges and latches)	SV63500	SV63500
13	Door latches (keeper) and screws	SV00887 (2) SV00601 (4)	SV00887 (2) SV00601 (4)
14	Diffuser	SV60822	SV60822
15	Filter kit	SV60800	SV60800
16	Core	SV60801	SV60803
17	Door latches and screws	SV00886 (2) SV00601 (4)	SV00886 (2) SV00601 (4)
18	Balancing damper	SV02253	SV02253
19	Balancing double collar port	SV02256	SV02256
*	Terminal connector	SV16416	SV16416
*	Hardware kit	SV20606	SV20606

* Not shown.

REPLACEMENT PARTS AND REPAIRS

In order to ensure your ventilation unit remains in good working condition, you must use Broan-NuTone LLC genuine replacement parts only. The Broan-NuTone LLC genuine replacement parts are specially designed for each unit and are manufactured to comply with all the applicable certification standards and maintain a high standard of safety. Any third party replacement part used may cause serious damage and drastically reduce the performance level of your unit, which will result in premature failing. Also, Broan-NuTone LLC recommends to contact a certified service depot for all replacement parts and repairs.

9. TROUBLESHOOTING

If the integrated control LED of the unit is flashing, this means the unit sensors detected a problem. See the list below to know what the problem is:

LED flashes GREEN (double blink).

- Thermistor error.

Replace the thermistor kit.

LED flashes AMBER.

- Damper error.

Go to point 10.

⚠ WARNING

- **A few diagnosis procedures may require the unit to be in operation while proceeding. Open the unit door and bypass its magnetic switch by putting the door white magnet on it. Be careful with moving and/or live parts.**
- **Risk of electric shocks. Electronic board connections must be checked by qualified personnel only.**

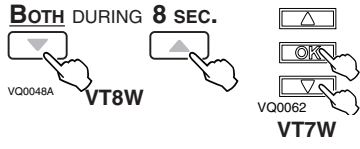
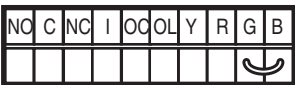
PROBLEMS	POSSIBLE CAUSES	YOU SHOULD TRY THIS
1. The error code E1 is displayed on the VT8W or VT7W wall control screen.	<ul style="list-style-type: none"> • The wires may be in reverse position. • The wires may be broken. • The wires may have a bad connection. 	<ul style="list-style-type: none"> • Ensure that the color coded wires have been connected to their appropriate places. • Inspect every wire and replace any that are damaged. • Ensure the wires are correctly connected.
2. There is no outside temperature displayed on VT8W wall control screen — — .	<ul style="list-style-type: none"> • Unit is on error and integrated control LED flashes (GREEN or AMBER). • The unit thermistor is defective (integrated control LED flashes GREEN). 	<p>NOTE: At its very start-up or after a power failure, it takes a few minutes before the outside temperature appears on screen. The delay depends on the operation mode the wall control is in. The shortest delay is obtained when the wall control is set on MIN or MAX in VENT Mode.</p> <ul style="list-style-type: none"> • Check if unit is operating. • Replace the unit thermistor.
3. VT8W or VT7W wall control screen alternates between normal display and E3 or E4 appears on screen.	<ul style="list-style-type: none"> • VT8W or VT7W wall control needs to be reset. • The VT8W or VT7W wall control is defective. 	<ul style="list-style-type: none"> • Reset the VT8W or VT7W wall control by pressing simultaneously on both keys for 8 second (as shown at right). Then, unplug the unit for 30 seconds. Plug the unit back.  <ul style="list-style-type: none"> • If the problem is not solved, replace the wall control.
4. On VT8W wall control, there is an important difference between temperature displayed and real temperature.	<ul style="list-style-type: none"> • Exterior air intake port is blocked. • The unit thermistor is defective (integrated control LED flashes GREEN). • The unit damper has been blocked or broken (integrated control LED flashes AMBER and unit is OFF). • Motor won't turn. 	<ul style="list-style-type: none"> • Clean the exterior air intake port. • Replace the unit thermistor. • Check for the proper operation of the unit damper; replace if necessary. • Confirm that the motor is running, if not refer to point 9.
5. Unit does not work (LED does not light up on the integrated control).	<ul style="list-style-type: none"> • The transformer may be defective. • The circuit board may be defective. • The unit is unplugged. • The unit door is opened. • A fuse is blown. • Wrong control connections. 	<ul style="list-style-type: none"> • Check for 24 VAC on J8-1 and J8-2. • Unplug the unit. Disconnect the main control and the optional(s) control(s) (if need be). Jump G and B terminals. Plug the unit back and wait about 10 seconds. If the motor runs on high speed and the damper opens, the circuit board is not defective. • Plug the unit. • Close unit door. • Unplug the product from the outlet. Inspect fuse on circuit board (F1 in wiring diagram on page 16). If the fuse is blown, discontinue using the unit and contact technical support. • Try the integrated control (see Section 4.1 on page 13). 

9. TROUBLESHOOTING (CONT'D)

PROBLEMS	POSSIBLE CAUSES	YOU SHOULD TRY THIS
6. The damper actuator does not work or rotates continuously.	<ul style="list-style-type: none"> The damper actuator or the integrated damper port mechanism may be defective (integrated control LED flashes AMBER and unit is OFF). The circuit board or the transformer may be defective (integrated control LED flashes AMBER and unit is OFF). 	<ul style="list-style-type: none"> Unplug the unit. Disconnect the main control and the optional controls(s) (if need be). Wait 10 seconds and plug the unit back. Check if the damper opens. If not, use a multimeter and check for 24 VAC on J12-1 and J12-2 (in electrical compartment). If there is 24 VAC, replace the entire port assembly. NOTE: It is normal to experience a small delay (7-8 seconds) before detecting the 24 VAC signal at starting-up. This signal will stay during 17-18 seconds before disappearing. If there is no 24 VAC, check for 24 VAC between J8-1 and J8-2. If there is 24 VAC replace the circuit board, and if there is no 24 VAC, change the transformer.
7. The wall control does not work OR its indicator flashes.	<ul style="list-style-type: none"> The wires may be in reverse position. The wires may be broken. The wire in the wall OR the wall control may be defective. 	<ul style="list-style-type: none"> Ensure that the color coded wires have been connected to their appropriate places. Inspect every wire and replace any that are damaged. Remove the wall control and test it right beside the unit using another shorter wire. If the wall control works there, change the wire. If it does not, change the wall control.
8. The push-button timer does not work OR its indicator light does not stay on.	<ul style="list-style-type: none"> The wires may be in reverse position. The push button may be defective. 	<ul style="list-style-type: none"> Ensure that the color coded wires have been connected to their appropriate places. Jump the OL and OC terminals. If the unit switches to high speed, remove the Dehumidistat or push button and test it right beside the unit using another shorter wire. If it works here, change the wire. If it doesn't, change the Dehumidistat or the push button.  <p>VE0098</p>
9. The motor does not work.	<ul style="list-style-type: none"> The circuit board may be defective. The motor may be defective. The motor capacitor may be defective. The motor is unplugged from inside the unit. The motor is unplugged from the electronic board (J4). There is a problem with the door magnet switch. JU-1 jumper is missing or in wrong position. 	<ul style="list-style-type: none"> Press on the integrated control push button until the unit turns on low speed (the LED will light AMBER). Using a multimeter, check the voltage on J9-4 and J9-3. Refer to Section 6 Wiring Diagram. The reading must be 120 VAC. Then set the unit on high speed by pressing on the integrated control push button one more time (the LED will light GREEN). Using a multimeter, check the voltage on J9-4 and J9-2. The reading must be 120 VAC. Check also between J4-2 and J4-1, the reading must be 120 VAC. Refer to Section 6 Wiring Diagram. If all the readings correspond to the right voltage values, the circuit board is not defective. If one or both readings are different, change the circuit board. Using a multimeter, check for 120 VAC for the following speeds: High Speed: between GREY and ORANGE wires; Low/Medium Speed: between GREY and RED/BLUE wires. Refer to Section 6 Wiring Diagram. Unplug the unit. Check for continuity between Pin 5 on the 6-pin connector (brown leads) and Pin 3 of the capacitor connector. Also check for continuity between Pin 4 on the 6-pin connector (brown leads) and Pin 1 of the capacitor connector. Refer to Section 6 Wiring Diagram. Open the door and ensure that the wire going to the motor is connected. Check J4 motor connection on circuit board. Door magnet switch is missing or not in its place (see item no. 11 on page 18). Ensure JU-1 jumper is set on "M" speed (refer to Section 6 Wiring Diagram).
10. The defrost cycle does not work (the fresh air duct is frozen OR the fresh air distributed is very cold).	<ul style="list-style-type: none"> Ice deposits may be hindering the damper operation. The damper rod or the port damper itself may be broken. The damper actuator or circuit board may be defective. 	<ul style="list-style-type: none"> Remove the ice. Inspect these parts and replace if necessary. See point 6.
11. The integrated control push button does not work.	<ul style="list-style-type: none"> The 30-second boot sequence is not completed. The circuit board may be defective. The transformer may be defective. 	<ul style="list-style-type: none"> See Section 4.1.1 Boot Sequence (page 13). Check voltage going to circuit board J8-1 and J8-2. Check for 24 VAC on J8-1 and J8-2.