

ROUGH-IN KIT WITH RADIATION DAMPER

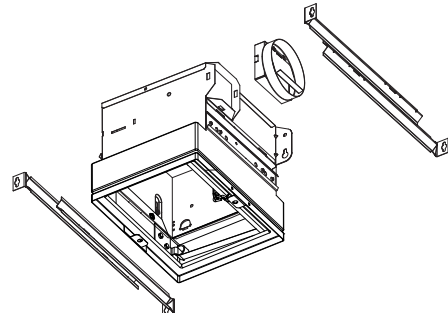

READ AND SAVE THESE INSTRUCTIONS

For Use in 1, 2 or 3 Hour Rated Floor-Ceiling and Roof-Ceiling Designs.

Horizontal Mount Only.

For use with the following Broan ventilation fan models:

- 80RDF, 110RDF, HD50RDF

The following components are included with this accessory kit:

- (1) Radiation Damper and Fan Housing Assembly
- (1) Metal Duct Connector
- (4) Support Angles
- (1) Housing Mask

Identify the following ventilation fan (purchased separately) components and discard:

- Plastic Fan Grille Assembly
- Plastic Duct Connector Assembly

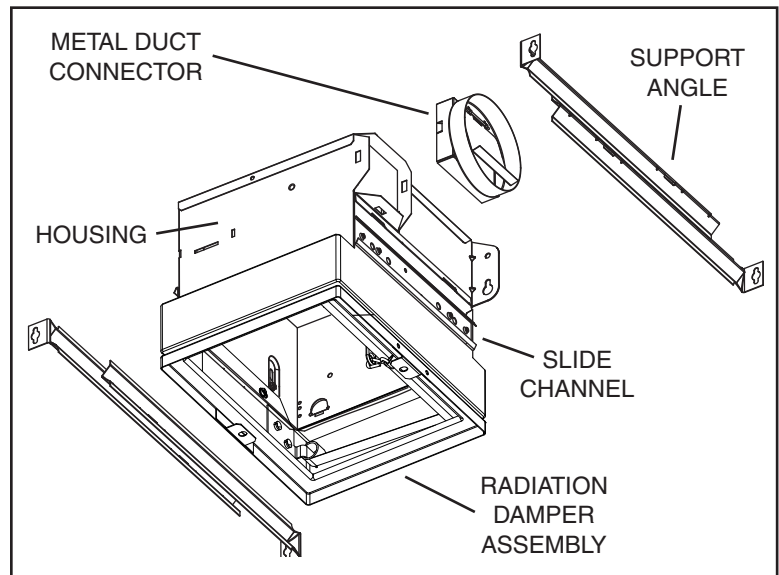

Assemble support angles and duct connector to ventilation fan housing:

1. Snap metal duct connector onto housing. Make sure that tabs on the duct connector lock into the slots on the housing. Damper flap hinge should be positioned toward top of housing.
2. Slide channels can be adjusted up or down to accommodate different ceiling thicknesses.
3. Insert (2) support angles into each slide channel.

NON-COMBUSTIBLE FLOOR / CEILING INSTALLATION

- Plan installation so that ceiling penetration is located within ceiling tiles or panels without necessitating cuts in any ceiling suspension main runners or cross tees. If required, a maximum of one runner or cross tee may be cut to accommodate desired damper location. Cut ends must be supported by a minimum 12 gauge (3mm) steel, vertical hanger wire.
- Mount fan/damper assembly to the deck or ceiling structure above or adjacent to the assembly. If the assembly is hung from the structure above, a minimum 12 gauge (3mm) steel, hanger wire must be used. There must be a minimum of two wires on each of two opposite sides. If the assembly is directly mounted to the adjacent structure, use #8 (M4) sheet metal screws or 1/4" (6mm) diameter bolts with nuts (hardware not provided) to mechanically fasten it to the structure. Position fan/damper assembly so that the inlet face of the radiation damper is flush with the finished surface of the ceiling. Ceiling opening must be no larger than the inlet opening of the damper.
- New Construction

A housing mask has been provided to keep construction dust, drywall spray, paint, etc. from damaging the radiation damper or blower assembly.

 - Bend up the small tab of the mask.
 - Tuck the opposite side of the mask under one of the damper's grille mounting ears and push mask up into damper housing.

Remove mask before installing grille or operating fan.
- Attach the metal grille over the inlet face of the radiation damper using (2) #8-18 x 0.812" sheet metal screws (provided).

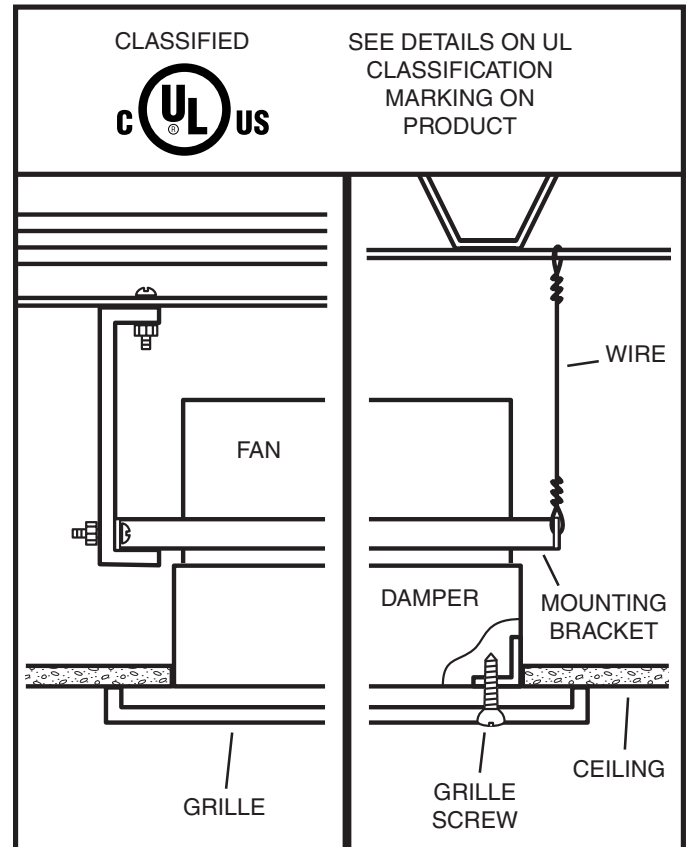

WOOD CONSTRUCTION FLOOR / CEILING INSTALLATION

- Position radiation damper on the inlet side of the fan so that the arrow in the damper will point **UP** in the finished installation. Attach the damper to the fan using #8 (M4) sheet metal screws (provided). There must be a minimum of two connections on each of two opposite sides. Care must be taken to ensure that the fasteners do not interfere with the closing of the damper curtain. For best results, use mounting holes provided.
- Position fan/damper assembly so that the inlet face of the radiation damper is flush with the finished surface of the ceiling. Fasten fan/damper assembly to the building structure by driving #10 (M5) minimum sheet metal screws or #8d minimum nails (hardware not provided) through the fan mounting brackets and into the ceiling joists. There must be a minimum of two fasteners on each of two opposite sides. **Ceiling opening must be no larger than the inlet opening of the damper.**
- New Construction

A housing mask has been provided to keep construction dust, drywall spray, paint, etc. from damaging the radiation damper or blower assembly.

 - Bend up the small tab of the mask.
 - Tuck the opposite side of the mask under one of the damper's grille mounting ears and push mask up into damper housing.

Note: Mask can be put in place before or after the blowers assembly is installed.

Remove mask before installing grille or operating fan.
- Attach the metal grille, supplied, over the inlet face of the radiation damper using #8 (M4) sheet metal screws (provided). There must be a minimum of one screw on each of two opposite sides. For best results, use mounting holes provided.

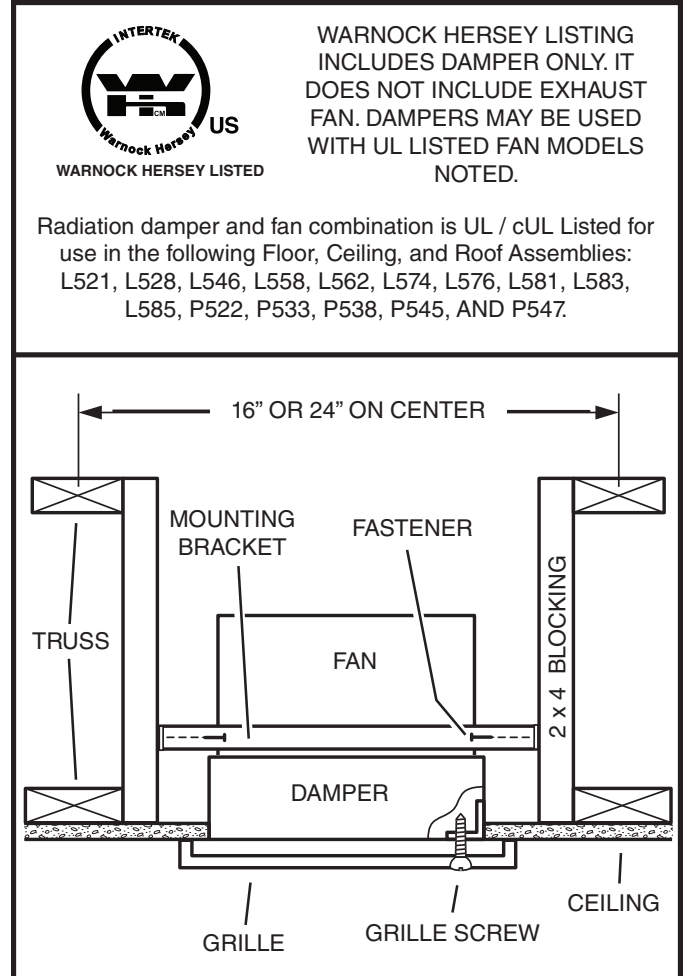

WARNOCK HERSEY LISTED

WARNOCK HERSEY LISTING INCLUDES DAMPER ONLY. IT DOES NOT INCLUDE EXHAUST FAN. DAMPERS MAY BE USED WITH UL LISTED FAN MODELS NOTED.

Radiation damper and fan combination is UL / cUL Listed for use in the following Floor, Ceiling, and Roof Assemblies: L521, L528, L546, L558, L562, L574, L576, L581, L583, L585, P522, P533, P538, P545, AND P547.

SERVICE PARTS

Key No.	Part No.	Description
1	99523579	Fusible Link
2	99260485	Sheet Metal Nut
3	99150573	Grille Screw
4	99523357	Radiation Damper
5	98009908	Metal Grille
6	97015727	Metal Duct Connector
7	98003036	Support Angle

