

For 16" cc joist, use metal sheet pliers to cut the horizontal bracket where indicated, then fold to break apart the extra length (grey section in illustration) and discard.

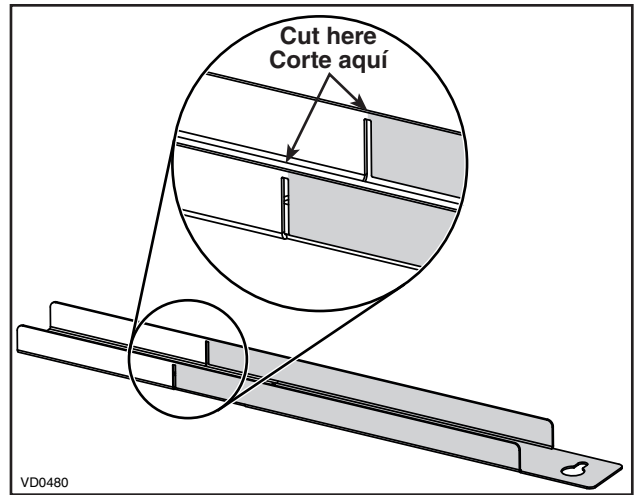

NOTE: The following procedure applies for both 16" cc joist and 24 "cc joist.

1. Attach horizontal bracket to current unit bracket using 2 included screws.
- 1.

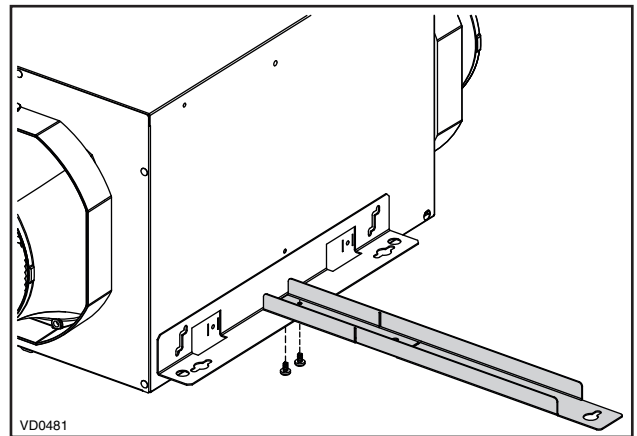

2. Attach the diagonal brace using 2 included screws.
2. Fije el tirante diagonal con los 2 tornillos incluidos.

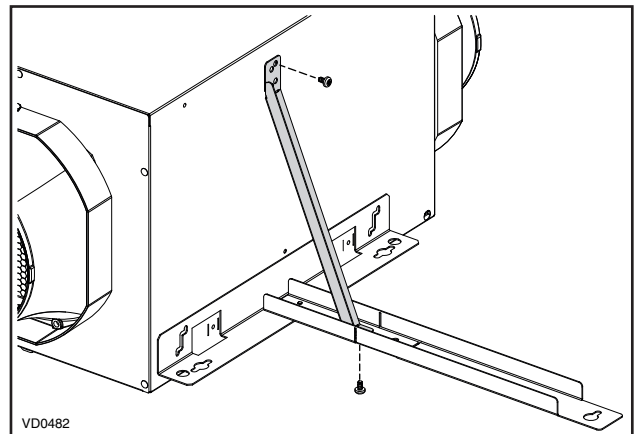

FIN-S1624

FRESH-IN INSTALLATION SUPPORT BRACKET