

MODEL AE50110DCSL FLEX DC™ SERIES HUMIDITY SENSING FAN / LIGHT

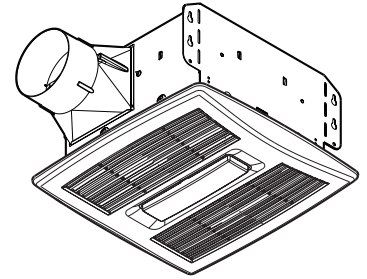

A modern-styled, high performance fan, with sensing circuitry, that "knows" when to ventilate the room.

FEATURES

BLOWER:

- Plug-in, permanently lubricated, brushless DC motor - engineered for continuous operation
- Dynamically balanced centrifugal blower wheel for quiet, efficient performance
- Low RPM for quiet operation
- Selectable settings of 50, 80 or 110 CFM

HOUSING:

- Rugged, 26 gauge, galvanized steel construction
- Polymeric, 4" damper / duct connector with tapered sleeve and no metallic clatter
- 5-3/4" height allows for 2" x 6" ceiling installations
- Sturdy, easy, four-point mounting directly to joist
- Optional snap-on flange kit

GRILLE:

- Polymeric construction
- Innovative design - the result of extensive research with designers and consumers
- 11-Watt integrated LED lighting for energy efficiency
- 3500K color temperature provides soft white light - ideal for bathroom illumination
- LED lasts up to 25,000 hours for maintenance-free convenience

DIMMING CONTROLS :

- Each application is unique and various factors such as load, common neutrals or other electrical products on the circuit can, in certain instances, cause variance in system performance

- Dimmer model numbers vary slightly depending on color, packaging type, etc. such that variations of model numbers may be suitable. Consult dimming system manufacturer for additional support in operation

AUTOMATIC CONTROL:

- Humidity control automatically turns fan ON when either of these conditions is detected:
 - a rapid to moderate (user adjustable) increase of humidity
 - humidity above user-adjustable set-point (50%-80% RH)
- Two wire manual operation for odor control - Turns fan ON when power line through wall switch is cycled ON, OFF and back ON
- Remains ON for a user-adjustable 5 to 60 minutes after humidity has stabilized and is below set-point or after manually initiated through power line cycling
- Saves energy because unit runs only for the time required. A unit controlled with a wall timer may keep fan ON longer than required or turn it OFF before room is sufficiently ventilated

U.L. Listed for use over bathtubs and showers when connected to a GFCI protected branch circuit (ceiling mount only)

U.L. Listed for use in insulated ceilings (Type I.C.)

3-Year Warranty



JA8-2019

PERFORMANCE RATINGS - MODEL AE50110DCSL FLEX DC™ SERIES HUMIDITY SENSING FAN / LIGHT

HVI PERFORMANCE

Speed Setting	Static Pressure (In. H ₂ O)	Airflow (CFM)	Sound (Sones)	Power (Watts)	Efficacy (CFM/W)
50	0.1	50	< 0.3	3.4	14.7
	0.25	36	0.5	5.3	6.7
80	0.1	80	0.4	6.5	12.6
	0.25	71	0.9	9.4	7.6
110	0.1	110	0.9	10.6	10.4
	0.25	105	1.4	14.9	7.0



HVI-2100 CERTIFIED RATINGS comply with new testing technologies and procedures prescribed by the Home Ventilating Institute, for off-the-shelf products, as they are available to consumers. Product performance is rated at 0.1 in. static pressure, based on tests conducted in a state-of-the-art test laboratory. Sones are a measure of humanly-perceived loudness, based on laboratory measurements.

AIR FLOW PERFORMANCE

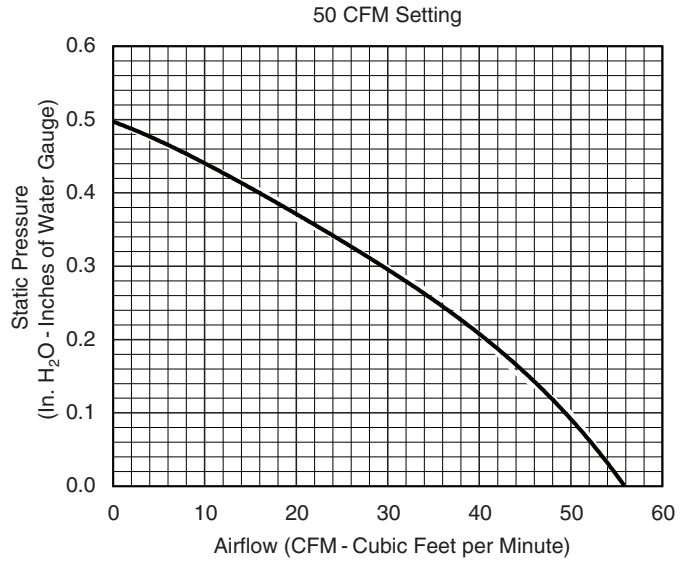

ELECTRICAL & WEIGHT

Volts	Hz	Amps	Shipping Weight
120	60	0.4	8.5 lb.



JA8-2019

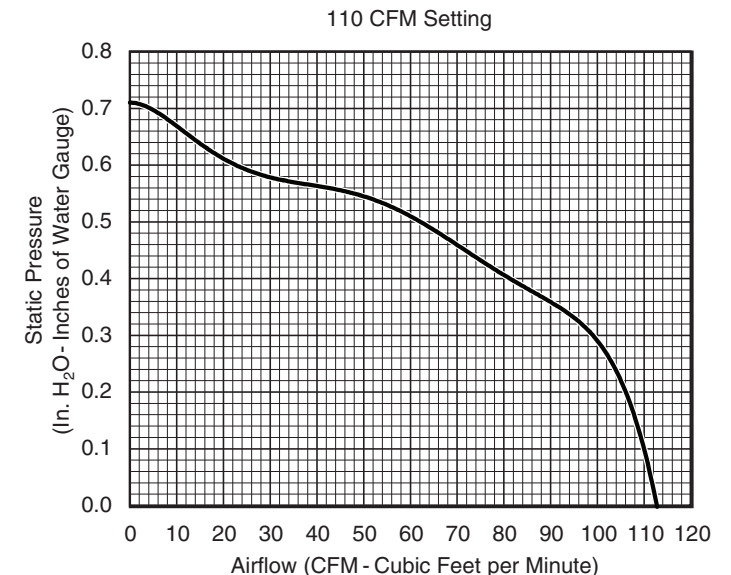
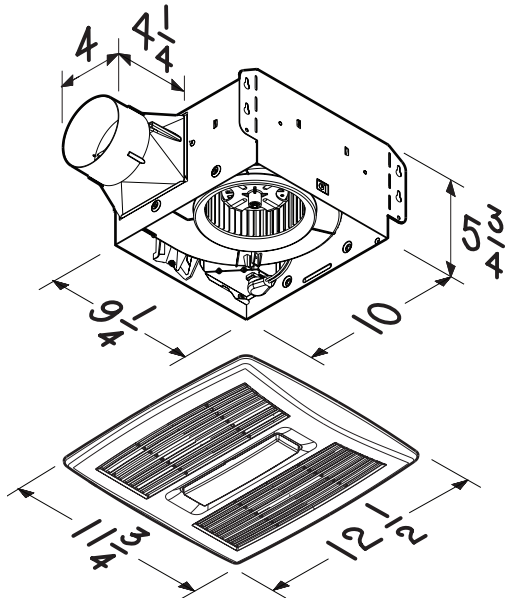
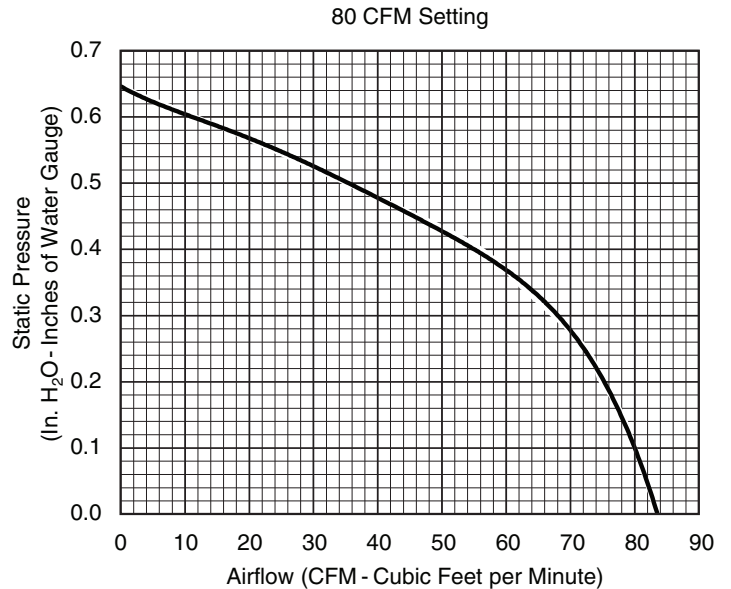

Find out more about home ventilations we have.