

MODELS 688 & 689 CEILING/WALL FANS

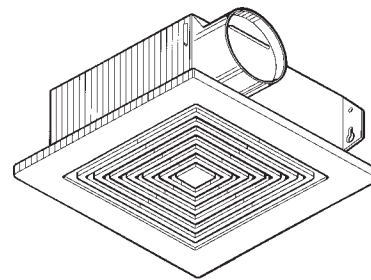

Versatile, high quality ventilators at economy prices.

FEATURES

GRILLE:

- White polymeric - blends well with any decor
- Torsion spring grille mounting - no tools required
- Metal grille kit available - purchase separately

MOTOR:

- Plug-in, permanently lubricated
- Broan-designed polymeric blower wheel
- Snap in/out motor assembly for easy cleaning - no screws to drive or drop

HOUSING:

- Compact, 25 gage galvanized steel - attaches easily to wall or ceiling joists
- Double strength mounting flanges with keyhole slots
- Removable wiring cover - make connections away from tight corners
- No electrical knockout to remove
- Polymeric duct fitting with tapered sleeve for easy, positive duct connection
- Quiet polymeric damper prevents cold backdrafts-no metallic clatter
- U.L. Listed for use over bathtubs and showers when connected to a GFCI protected branch circuit.

CONTROLS DESIGNED FOR USE WITH THESE PRODUCTS (purchase separately):

- Model 59V (Ivory)/59W (White) 60-Minute Time Control
- Model 57V (Ivory)/57W (White) Electronic Variable Speed Control - 3 amp
- Model 69V (Ivory)/69W (White) Single-Function Control

MODEL 1667H: Rough-in housing for Models 1688F and 1689F finish assemblies (packed 6 per carton).

MODEL 1667HMTL: Rough-in housing with metal duct connector for Models 1688F and 1689F finish assemblies (packed 6 per carton).

SPECIFICATIONS

MODEL	VOLTS	AMPS	SONES	CFM	DUCT
688	120	0.9	4.0	50	3" Round
689	120	1.5	5.5	60	3" Round

TYPICAL SPECIFICATION

Ventilator shall be Broan Model 688 (Broan Model 689).

Ventilator shall have galvanized steel housing with double-strength mounting flanges. It shall be ducted vertically (horizontally) to a roof cap (wall cap).

Motor assembly shall be removable and permanently lubricated.

Air delivery shall be no less than 50 CFM and sound levels no greater than 4.0 Sones (Model 688), 60 CFM and 5.5 Sones (Models 689). All air and sound ratings shall be certified by HVI. Units shall be U.L. Listed.

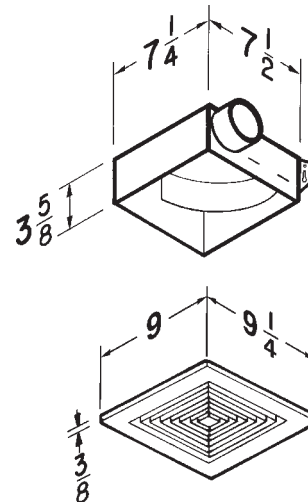

HVI-2100 CERTIFIED RATINGS comply with new testing technologies and procedures prescribed by the Home Ventilating Institute, for off-the-shelf products, as they are available to consumers. Product performance is rated at 0.1 in. static pressure, based on tests conducted in AMCA's state-of-the-art test laboratory. Sones are a measure of humanly-perceived loudness, based on laboratory measurements.

