

ROOF MOUNTED POWERED ATTIC VENTILATORS

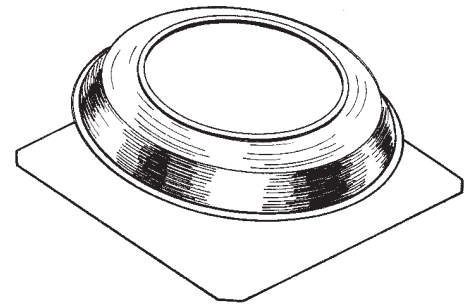

Powerful and easy to install, these units supplement or replace air conditioning by removing the blanket of hot, trapped air from attics - automatically.

FEATURES

- Precision balanced 14" metal blade for maximum air flow - minimum sound level
- PVC plastic dome provides ultraviolet protection and superior durability (Models 350BK*, 350BR*, 355BK, 355BR, 356BK*, 356BR*)
- .050 aluminum dome (Model 358)
- 23 gage metal flashing - allows for nailing and hot tar application
- Mesh bird screen
- Built-in adjustable thermostat - for automatic operation at your chosen temperature level
- Thermally protected, permanently lubricated motor
- Mounts easily between rafters - installation template included

CONTROLS DESIGNED FOR USE WITH THESE PRODUCTS (purchase separately):

- Model 69W (White) Single-Function Control
- Model 72W (White) Electronic Variable Speed Control- 6 amp (not for use with Model 356*)

Can be used to ventilate excess heat and humidity from single family, residential garages.

SPECIFICATIONS

MODEL	VOLTS	AMPS	RPM	CFM	ATTIC MAX. SQ. FT.	MIN. INLET AREA
350BK*, 350BR*	120	3.6	1000	1050	1500	3.5 SQ. FT.
355BK, 355BR	120	4.3	1050	1000	1400	4.0 SQ. FT.
356BK*, 356BR*	120	8.0	1500	1600	2285	5.5 SQ. FT.
358	120	4.3	1050	1000	1400	4.0 SQ. FT.



* HVI-2100 CERTIFIED RATINGS comply with new testing technologies and procedures prescribed by the Home Ventilating Institute, for off-the-shelf products, as they are available to consumers. Product performance is rated at 0.1 in. static pressure, based on tests conducted in a state-of-the-art test laboratory. Sones are a measure of humanly-perceived loudness, based on laboratory measurements.

TYPICAL SPECIFICATION

Roof Mounted Attic Ventilator shall be Broan Model 350BK* (350BR*) (355BK) (355BR) (356BK*) (356BR*) (358).

Ventilator shall have metal blade and flashing plate. Bird screen to be included.

Dome to be ultraviolet resistant plastic. (.050 Approx. 18 gage aluminum). Motor to be thermally protected and permanently lubricated. RPM not to exceed 1000 (Models 350BK*, 350BR*), 1100 (Models 355BK, 355BR, 358), 1500 (Models 356BK*, 356BR*).

Ventilator shall have a built-in adjustable thermostat and mount easily between rafters or wall studs.

Air delivery shall be no less than 1050 CFM (Models 350BK*, 350BR*), 1000 CFM (Models 355BK, 355BR, 358), 1600 CFM (Models 356BK*, 356BR*). Units to be U.L. Listed.

