

Table of Contents

Important Safeguards	3
Before Your First Use	6
Know the Parts of Your Buffet Server	9
Using Your Buffet Server	10
Cleaning Your Buffet Server.....	13
Limited Warranty	14
To Return for Service.....	15
Replacement Parts	16



Betty Crocker™

STAINLESS STEEL
DOUBLE

Buffet Server

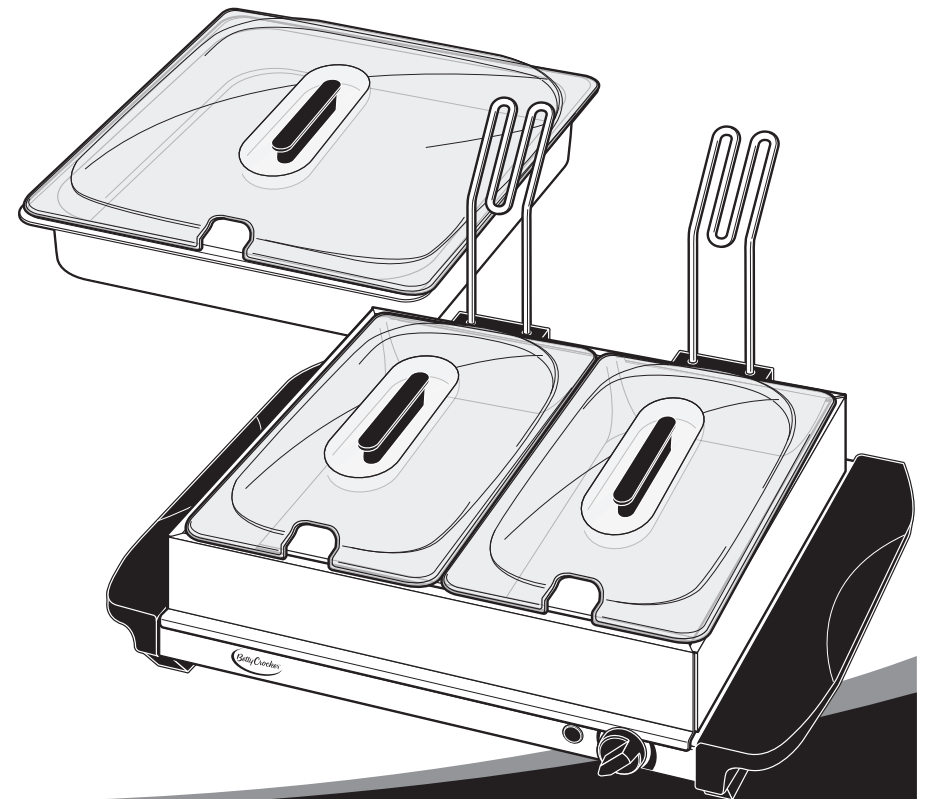

HOUSEHOLD USE ONLY

BC-2587CY

15. Do not fill tray with more than 2/3 of the total capacity.
16. Do not twist, kink or wrap the power cord around the appliance as this may cause the insulation to weaken and split, particularly in the location where it enters the unit.
17. **Do not leave appliance unattended while in use.**

SAVE THESE INSTRUCTIONS HOUSEHOLD USE ONLY

IMPORTANT SAFEGUARDS

When using electrical appliances, basic safety precautions should always be followed to reduce the risk of fire, electric shock and/or injury to persons, including the following:

1. **READ ALL INSTRUCTIONS CAREFULLY.**
2. Do not touch hot surfaces. Use handles or knobs.
3. To protect against electrical shock do not immerse cord, plugs or unit in water or other liquid.
4. Close supervision is necessary when any appliance is used by or near children.
5. Unplug from outlet when not in use and before cleaning. Allow to cool before putting on or taking off parts.
6. Do not operate any appliance with a damaged cord or plug or after the appliance malfunctions or has been damaged in any manner. Return the appliance to the nearest authorized service facility for examination, repair or adjustment.
7. The use of accessory attachments not recommended by the appliance manufacturer may cause injuries.
8. Do not use outdoors.
9. Do not let cord hang over edge of table or counter, or touch hot surfaces.
10. Do not place on or near hot gas or electric burner, or in a heated oven.
11. Extreme caution must be used when moving the appliance containing hot oil or other hot liquids.
12. To disconnect, turn the control knob to "OFF" then remove the plug from the wall outlet.
13. Do not use appliance for other than intended use.
14. Do not place the appliance in the presence of explosives and/or flammable fumes.

Before Your First Use

Carefully unpack your Betty Crocker™ stainless steel buffet server and remove all packaging materials. Included in the box are 2 lid hangers. Be certain to remove these from the box while unpacking the unit.

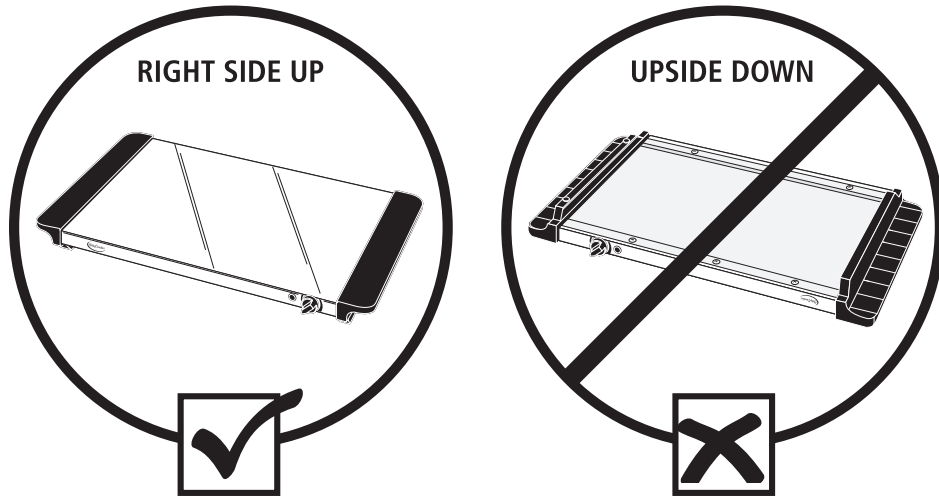

ATTENTION:

1. Ensure the warming plate, once removed from its packaging, is then placed on a flat, level surface that is not sensitive to heat. When placed correctly the Betty Crocker logo is facing right side up. Please refer to the above diagram for correct placement.
2. When the warming plate has been properly placed, the retaining shelf and buffet server vessels can be placed on the heating plate. Refer to page 10 in your owner's manual for assembling instructions.

POWER CORD INSTRUCTIONS

1. A short power-supply cord is provided to reduce the hazard resulting from entanglement or tripping over a long cord.
2. Extension cords may be used if care is exercised. If it is necessary to use an extension cord, it should be positioned so that it does not drape over the counter or tabletop where it can be pulled on by children or tripped over unintentionally.
3. The electrical rating of the extension cord must be the same or more than the wattage of the appliance (the wattage is shown on the rating label located on the underside or back of the appliance).
4. Use only 3-wire extension cord with a 3-prong grounded plug.
5. Avoid pulling or straining the power cord at outlet or appliance connections.

GROUNDING PLUG

1. This appliance is equipped with 3-wire cord having a grounded plug.
2. To reduce the risk of injury this plug must be inserted into a properly installed and grounded outlet.
3. Do not attempt to defeat this safety feature by modifying the plug in any way.

WARNING: Improper use of the power cord may result in the risk of electric shock. Consult a qualified electrician if necessary.

WARNING:
DO NOT USE ABRASIVE MATERIALS ON ANY PART OF THE UNIT.

WARNING:
DO NOT IMMERSE THE WARMING TRAY OR PLUG IN WATER OR OTHER LIQUIDS.

WARNING:
NEVER PLUG IN AND TURN ON YOUR STAINLESS STEEL BUFFET SERVER AND LEAVE UNATTENDED WITHOUT FOOD OR LIQUIDS INSIDE BUFFET TRAYS.

WARNING:
NEVER LEAVE AN APPLIANCE UNATTENDED WHILE IN USE.

WARNING:
DO NOT PLACE ANY PARTS INTO A HEATED OVEN.

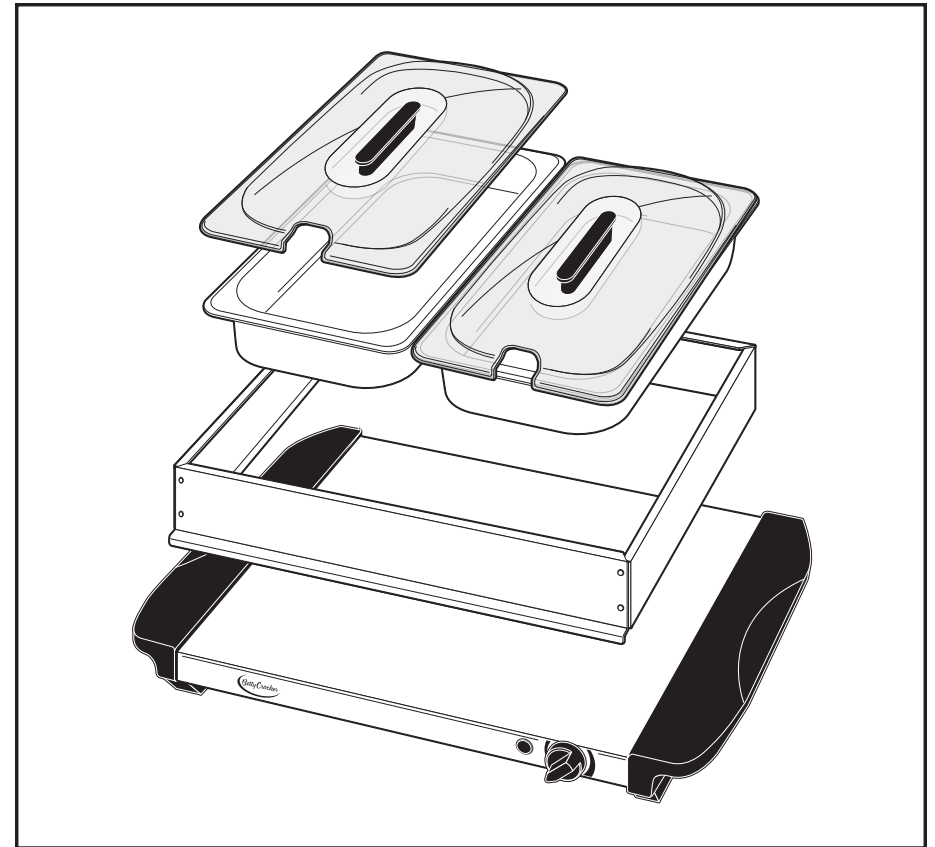

NOTE: Ensure that if you place the buffet server on a delicate surface, basic precautions should be taken, and any material placed beneath the buffet server must be made of a heat resistant, protective surface to prevent heat transfer or melting.

You may wipe the warming plate, retaining shelf, buffet trays and dome lids with a clean, damp cloth. Do not immerse the warming plate in water or any other liquid.

NOTE: The first time you use your buffet server, it may emit a slight odor. This is normal and is common for appliances that operate at high temperatures.

Using Your Buffet Server

1. Clean and dry your buffet server thoroughly before use. See the "Cleaning Your Buffet Server" section on pg. 13 of this manual.
2. **CAUTION: Place your buffet server on a flat, level surface, such as a table or countertop. Ensure that if you place the buffet server on a delicate surface, basic precautions should be taken, and any material placed beneath the buffet server must be made of a heat resistant protective surface to prevent heat transfer or melting.**
3. Turn the temperature control setting to the "OFF" position. Plug the unit into a 120 volt 60 Hz AC-only outlet.
4. Place defrosted or pre-heated food into the buffet tray(s) to be used.
NOTE: THE BUFFET SERVER IS NOT INTENDED TO DEFROST OR COOK FOOD. THE BUFFET SERVER IS TO KEEP FOOD WARM FOR SERVING.

5. Place the retaining shelf on the warming plate and insert the filled buffet trays or the single 5 quart tray onto the retaining shelf as seen in fig.1.

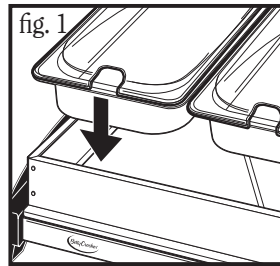

6. If the buffet trays are not filled or become empty, remove the buffet tray(s) from the warming plate.

WARNING: Use oven mitts or hand protection to remove an empty buffet tray as the buffet trays are hot.

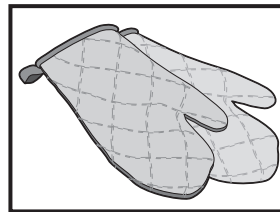

7. Turn the temperature setting knob to the low setting and the power on indicator light will illuminate.

8. Adjust the temperature setting knob to the desired temperature.

NOTE: The power on indicator light also functions as a temperature indicator light. Once the buffet server has achieved the desired temperature the unit shuts off as well as the power on indicator light. This function allows the buffet server to regulate the temperature. Refer to fig. 2 which outlines the various temperature settings.

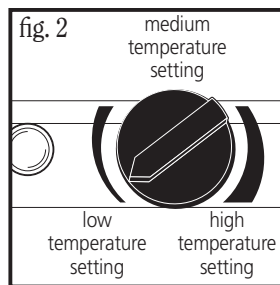

Know the Parts of Your Buffet Server

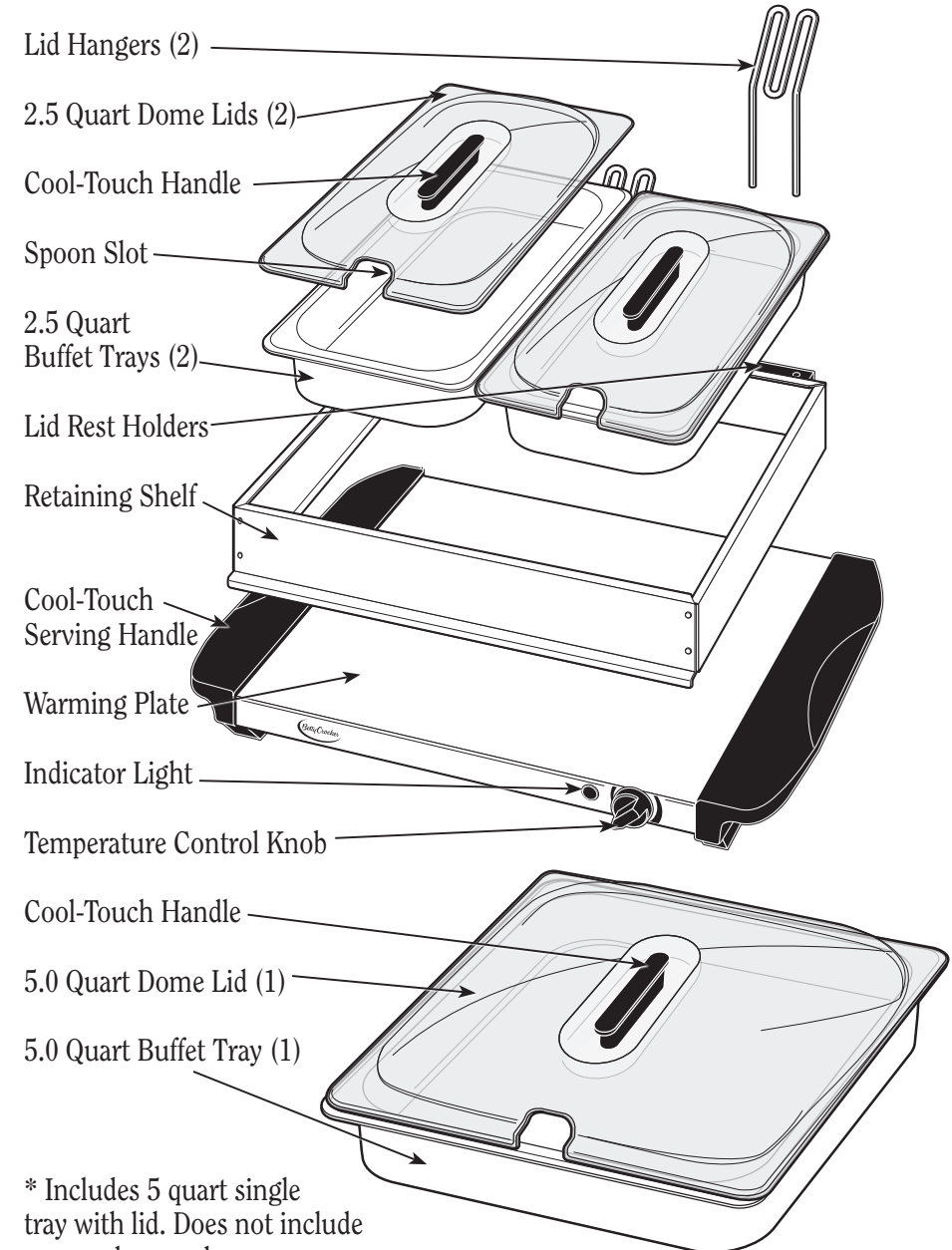

* Includes 5 quart single tray with lid. Does not include a second power base.

RATING: 120 V, 60 Hz, 200 W, AC ONLY

Using the Warming Plate Only

1. Clean and dry the warming plate thoroughly before use. See the “Cleaning Your Buffet Server” section on pg. 13 of this manual.
2. **CAUTION: Place your buffet server on a flat, level surface, such as a table or countertop. Ensure that if you place the buffet server on a delicate surface, basic precautions should be taken, and any material placed beneath the buffet server must be made of a heat resistant protective surface to prevent heat transfer or melting.**
3. Turn the temperature control setting to the “OFF” position. Plug the unit in a 120 volt 60 Hz AC-only outlet.

NOTE: Do not use the retaining shelf, buffet trays or clear lids when using as a warming tray.

4. Set the temperature control to the desired setting.

NOTE: The power on indicator light also functions as a temperature indicator light. Once the buffet server has achieved the desired temperature the unit shuts off as well as the power on indicator light. This function allows the buffet server to regulate the temperature.

5. Place heat-safe dishes with or without food on the warming plate to keep warm. The warming plate is not intended to defrost or cook food.

CAUTION: Do not place clear dome lids on warming plate surface.

6. It is not recommended to exceed 2-3 hours or food may begin to dry out.

CAUTION: The warming plate is not designed to keep large, deep pots full of food or liquid warm. Utilize containers that are heat-proof.

7. Once you are through using the warming plate, turn the temperature control setting to the “OFF” position and unplug from the outlet.
8. Allow the warming plate to completely cool down before cleaning and storage.

9. The buffet server can keep food warm for a long period of time if the dome lids are used. It is not recommended to exceed 3 hours or food may begin to dry out.
10. You can utilize the detachable lid hangers during buffet serving by simply inserting the lid hangers into the lid rest holders on the back of the buffet retaining shelf. Lids can then be hung by the lid handles when you are ready to serve. See fig.3.

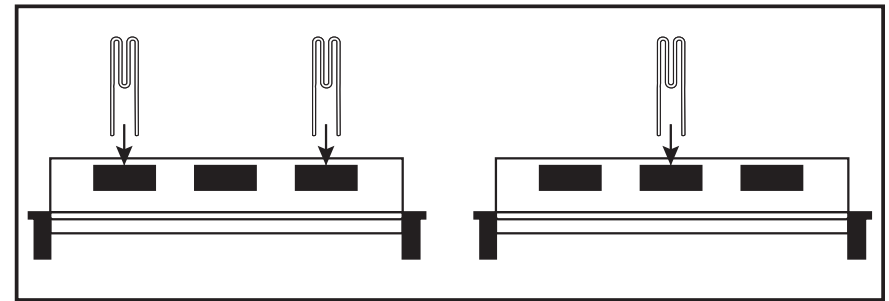
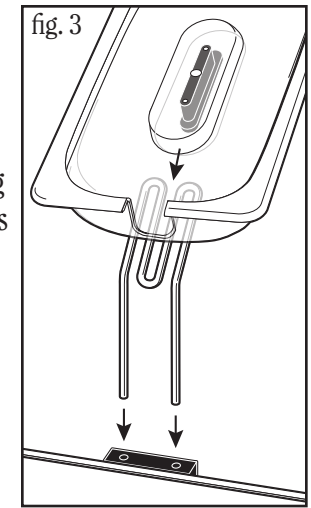

CAUTION: Foods with little or no liquid should be set on a low setting and stirred occasionally.

WARNING: DO NOT TURN ON YOUR BUFFET SERVER WITH EMPTY BUFFET TRAYS.

11. Once you are through using the buffet server, turn the temperature setting to the “OFF” position.
12. Remove the plug from the wall outlet.
13. Remove any remaining food from the buffet trays.
14. Allow the warming plate to completely cool down before cleaning and storage.

REPLACEMENT PARTS

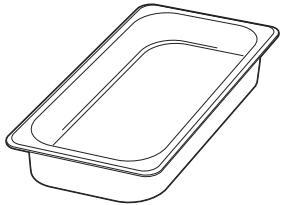

2.5 Quart Buffet Tray

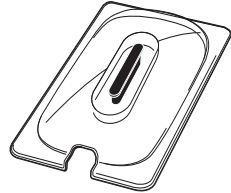

2.5 Quart Dome Lid

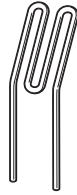

Lid Hanger

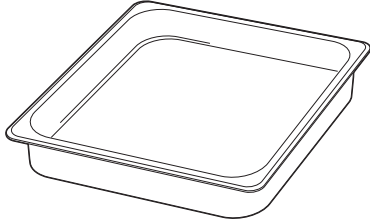

5.0 Quart Buffet Tray

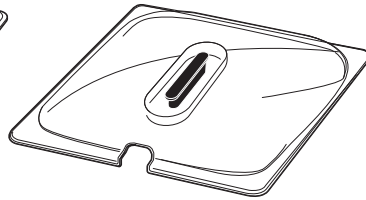

5.0 Quart Dome Lid

Cleaning Your Buffet Server

Other than the care and cleaning procedures mentioned in this manual, no other servicing or maintenance of this unit is necessary.

CAUTION: Be sure to unplug the buffet server and ensure the unit has cooled before cleaning. To protect against electric shock, do not immerse cord, plug or warming tray in water or other liquid.

Wash the dome lids, buffet trays and retaining shelf with warm soapy water using a sponge or dishcloth. Rinse thoroughly to remove soap residue then dry with a soft cloth.

The warming plate may be wiped with a clean, damp cloth or sponge. If desired a mild soap solution may be used.

NOTE: Do not use harsh or abrasive cleaners or scouring pads on any part of the buffet server.

NOTE: Do not allow water to spill or seep into the warming plate frame.

NOTE: Store lid hangers in the buffet trays. It is recommended wrapping the lid hangers in paper towel to avoid scratching the buffet trays.