

AUTO-DRAIN 24130-3" & 24140-1.5" INSTRUCTIONS

IMPORTANT: It is RECOMMENDED that the holding tank be empty before installation and initial operation of Auto-Drain. It is NOT necessary to remove valves to install Auto-Drain.

TOOLS REQUIRED: 5/32 allen wrench, phillips screw driver, adjustable wrench, wire cutters, and crimp tool.

INSTALLATION:

NOTE: It is not necessary to remove valves to install Auto-Drain

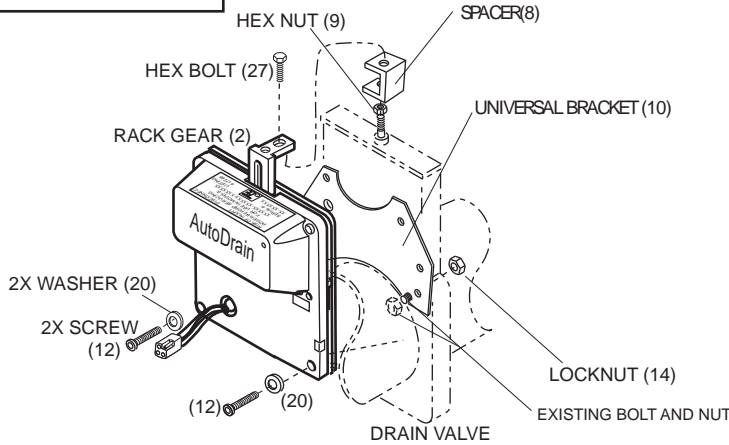

3" AUTO-DRAIN SHOWN

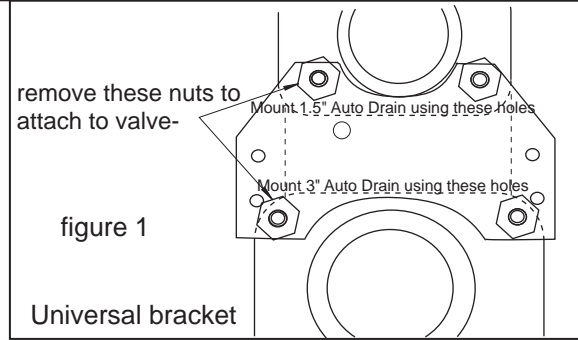

figure 1

Universal bracket

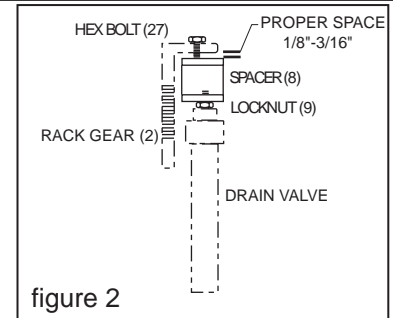

figure 2

- Using two existing flange bolts on the Drain valve, remove nuts, align holes in Universal Bracket (10). See figure 1 for placement, replace nuts.
- Remove valve handle (not shown).
- Thread nut (9) and spacer (8) onto shaft, press down on spacer to make sure shaft is all the way in and valve is fully closed.
- IMPORTANT:** Before you install the Auto-Drain to the valve ensure that the safety space is provided (see figure 2). This space is needed so that the valve will fully close without jamming the electrical mechanism and damaging the Auto-Drain. To set this ensure valve and Auto-Drain are in the fully closed position. Place the mounting rib on the back of the Auto-Drain to the top of the universal mounting bracket (10), thread spacer (8) up or down on the valve shaft as needed to achieve the space as in figure 2. Once space is set, lock nut (9) to spacer (8) then attach Auto-Drain to bracket by installing screws (12), washers (20) and lock nuts (14). Install bolt (27) and tighten pulling spacer up to the rack gear, ensure spacer and shaft DO NOT turn freely.
- Mechanical installation is now complete.

ELECTRICAL INSTALLATION:

Mount switch in a compartment close to Auto-Drain. Insure switch cannot be pushed accidentally by articles stored in the compartment.

Connect rocker switch box black wire to a constant positive 12 volts OR if using optional Power Disconnect Key Switch see below.

Connect rocker switch box white wire to ground (-12VDC).

Connect connector assembly of switch box to connector assembly of Auto-Drain.

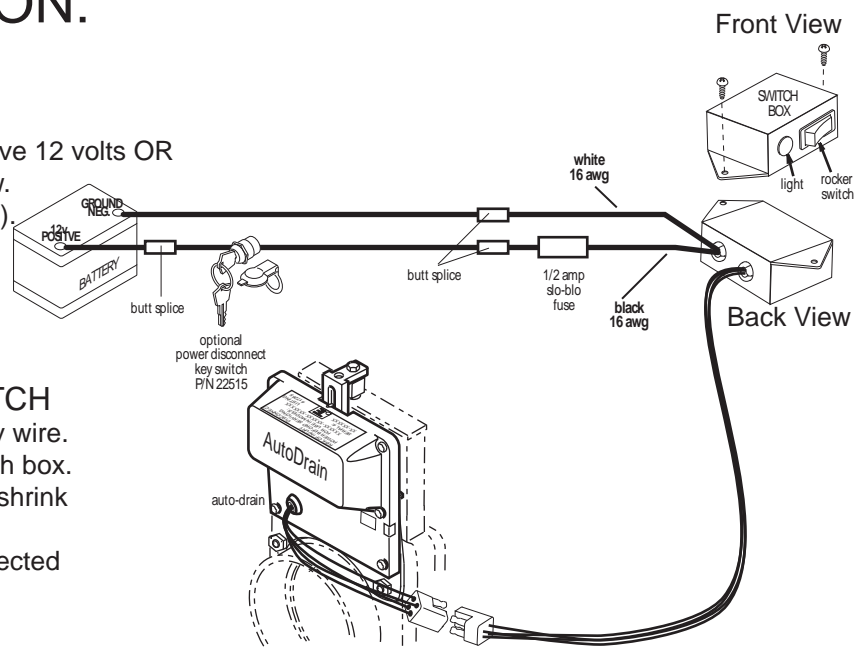

OPTIONAL POWER DISCONNECT KEY SWITCH

- Connect terminal #1 of key switch to (+) positive battery wire.
- Connect terminal #3 of key switch to white wire of switch box.
- Terminal #8 will not be used, it may be cover with heat-shrink or clipped off.
- To prevent electrical problems terminals should be protected by insulated connectors or heat-shrink.

AUTO-DRAIN 24130-3" & 24140-1.5" INSTRUCTIONS

OPERATION:

Insure drain valve is properly connected to drain hose. Push and hold rocker switch for 3-4 seconds to fully open or close valve. The indicator light on the switch box will be on at any time the valve is not fully closed. Hold the switch in the closed position until the light goes out.

Be careful when cleaning drain valve, Auto-Drain applies enough force to cause injury.

To manually open valve, remove the 2 (12) screws. This will free the Auto-Drain from the valve housing and allow you to pull/push on the Auto-Drain to open or close the valve.

Reminder!! Leave proper spacing between spacer and rack gear (1/8"-3/16") when assembling. **Prior to tightening bolt (10) see installation notes under IMPORTANT on page 1.**

ORANGE WIRE TO MOTOR
VIOLET WIRE TO MOTOR
GREEN WIRE
BROWN WIRE

SWITCH BOX ASSY #34

(ONE SCREW SUPPLIED WITH MOTOR BOX ASSY)

ITEM	DESCRIPTION	QTY	PART#
16	SHAFT	1	24749
17	CAM	2	30376
18	SWITCH	1	738-0055
19	SCREW(#4-40 X .62)	2	602-0005
20	WASHER	2	80208
21	CONNECTOR ASSY	1	31478
22	STRAIN RELIEF	1	12819
23	SWITCH BOX	1	31471
24	SCREW(#6 X 1")	2	606-0002
25	ROCKER SWITCH	1	738-0007
26	LAMP ASS'Y	1	31479
27	HEX BOLT	1	600-0077
28	PATENT LABEL	1	27129
29	PLATE SUPPORT	1	28429
30	BOX LABEL	1	23087
31	WARNING LABEL	1	25476
32	MALE CONNECTOR ASS'Y	1	31477
33	IN-LINE FUSE ASS'Y	1	31855
34	SWITCH BOX ASS'Y	1	31472
35	STRAIN RELIEF	1	17311
36	STRAIN RELIEF	1	743-0016
37	TERMINAL	2	742-0051
38	WIRE BLACK 24"	1	23136
39	WIRE WHITE 24"	1	23137
40	SCREW(#5-40X .63)	1	602-0035

(NOT SHOWN- COVER FOR SWITCH BOX- P/N 24006)

PARTS LIST FOR 3" AUTO-DRAIN

ITEM	DESCRIPTION	QTY	PART#
1	BASE, MACHINED	1	31473
2	RACK GEAR	1	24131
3	COVER, MACHINED	1	26876
4	AUTO DRAIN LABEL	1	25012
5	WARNING/SERIAL LABEL	1	25366
6	DRIVE GEAR	1	24134
7	MOTOR BOX ASS'Y	1	24122
8	SPACER	1	30992
9	HEX NUT .25-20	1	610-0006
10	UNIVERSAL BRACKET	1	30993
11	SCREW(#4-24)	4	605-0007
12	SCREW(#10-32 X 1.12")	2	601-1006
13	WASHER	1	80225
14	LOCKNUT(#10-32)	2	611-2100
15	"E" RING	1	634-1250

AUTO-DRAIN 24130-3", 24140-1.5" INSTRUCTIONS

PARTS LIST FOR 1.5" AUTO-DRAIN

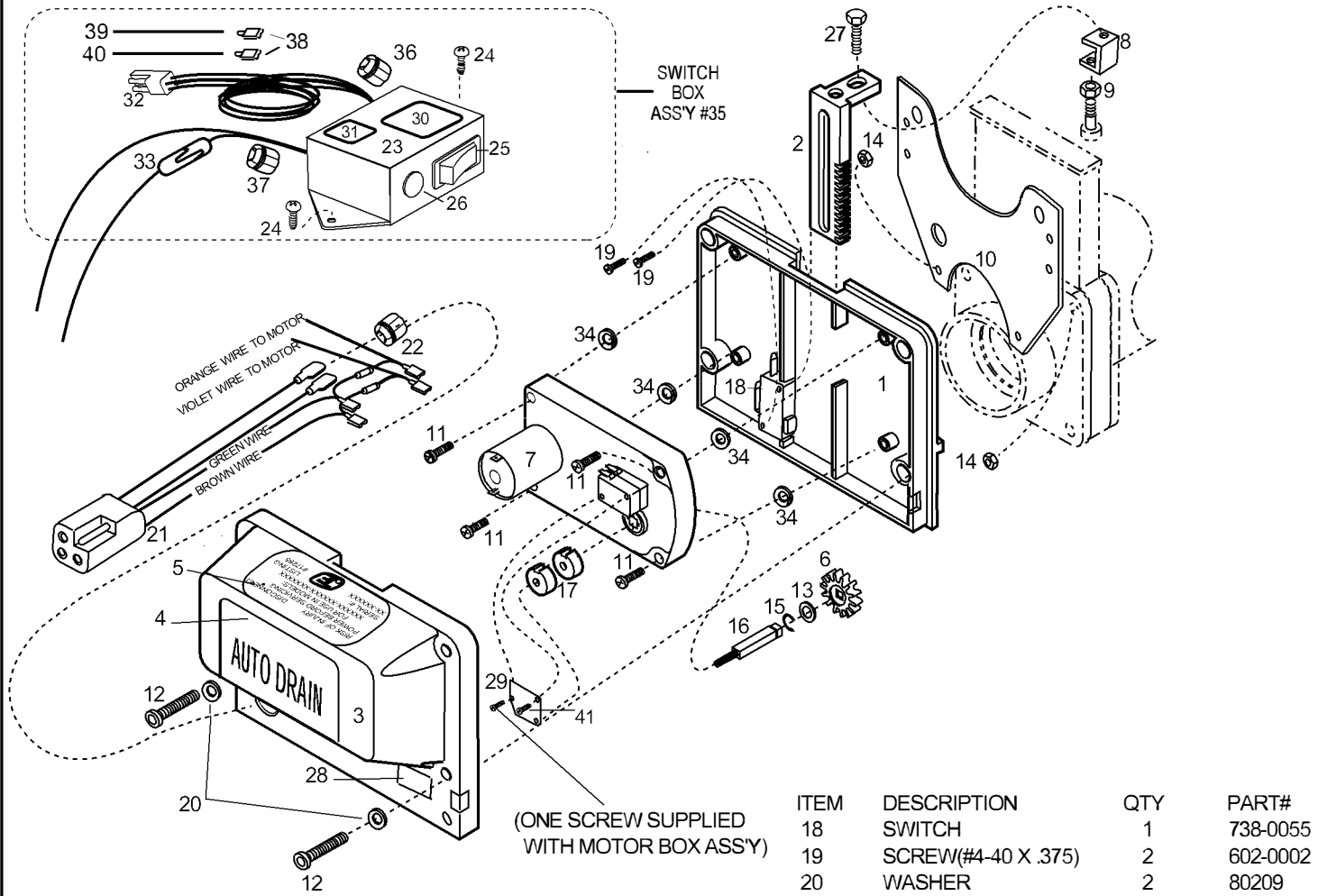

ITEM	DESCRIPTION	QTY	PART#	ITEM	DESCRIPTION	QTY	PART#
1	BASE, MACHINED	1	31919	18	SWITCH	1	738-0055
2	RACK GEAR	1	24136	19	SCREW(#4-40 X .375)	2	602-0002
3	COVER, MACHINED	1	26867	20	WASHER	2	80209
4	AUTO DRAIN LABEL	1	25011	21	CONNECTOR ASS'Y	1	31478
5	WARNING/SERIAL LABEL	1	25364	22	STRAIN RELIEF	1	12819
6	DRIVE GEAR	1	24134	23	SWITCH BOX	1	31471
7	MOTOR BOX ASS'Y	1	24122	24	SCREW (#6 X 1")	2	606-0002
8	SPACER	1	30992	25	ROCKER SWITCH	1	738-0007
9	HEX NUT .25-20	1	610-0006	26	LAMP ASS'Y	1	31479
10	UNIVERSAL BRACKET	1	30993	27	HEX BOLT	1	600-0077
11	SCREW (#4-24)	4	605-0007	28	PATENT LABEL	1	27129
12	SCREW (#10-32 X 1.12")	2	601-1006	29	PLATE SUPPORT	1	28429
13	WASHER	1	80225	30	BOX LABEL	1	23087
14	LOCKNUT (#10-32)	2	611-2100	31	WARNING LABEL	1	25476
15	"E" RING	1	634-1250	32	MALE CONNECTOR ASS'Y	1	31477
16	SHAFT	1	24749	33	IN-LINE FUSE ASS'Y	1	31855
17	CAM	2	30376	34	WASHER	4	80209
				35	SWITCH BOX ASS'Y	1	31472
				36	STRAIN RELIEF	1	17311
				37	STRAIN RELIEF	1	743-0016
				38	TERMINAL	2	742-0051
				39	WIRE BLACK 24"	1	23136
				40	WIRE WHITE 24"	1	23137
				41	SCREW (#5-40X .63)	1	602-0035

(NOT SHOWN- COVER FOR SWITCH BOX- P/N 24006)