



# GOOSENECK TRI-POD STABILIZING JACK

MODEL 25037

FOR USE ON FIFTH WHEEL TRAVEL TRAILERS

## ASSEMBLY AND OPERATING INSTRUCTIONS

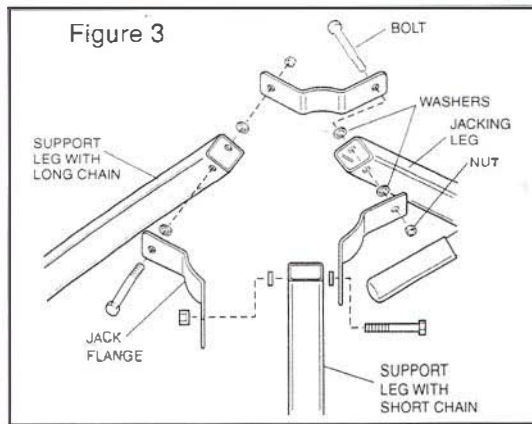
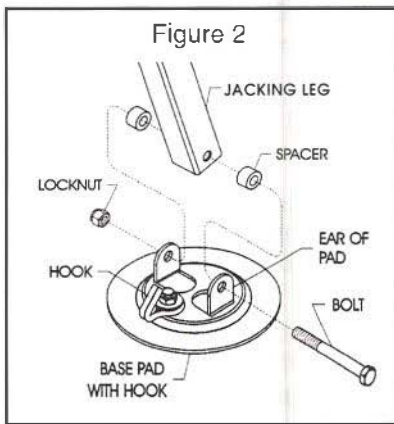
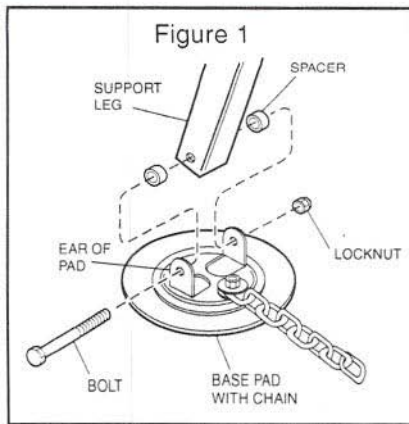

**SUPPORT LEG ASSEMBLIES:** 1) The base pad assembled with the long chain and base pad assembled with short chain and locking clasp fit on the bottom of the support legs. The chains should be positioned inbound as shown in figure 1. 2) Position the support legs between the ears of the base pads. Insert spacers (index #14) between the support tubes and the base pad ears. Align the holes in the spacers, base pad ears, and support tubes and secure them with the bolts and locknuts provided.

**JACK LEG ASSEMBLY:** 1) The base pad assembled with the hook fits on the bottom of the jacking leg. The hook of the base pad should be positioned inbound as shown in figure 2. 2) Position the jacking leg between the ears of the base pad. Insert spacers (index #14) between the jacking leg and base pad ears. Align the holes in the spacers, base pad ears, and jacking leg and secure them with the bolt and locknut provided.

**MAIN ASSEMBLY:** 1) Connect the tops of the support legs and jacking leg with the three jack flanges, bolts, nylon washers and nuts provided (see figure 3).

## PARTS LIST

INDEX NO.	PART NO.	DESCRIPTION	QTY
1	825102	OUTER TUBE ASSEMBLY (Jacking Leg)	1
2	P852028	TUBE/NUT ASSEMBLY	1
3	P852018	SCREW ASSEMBLY	1
4	825101	SUPPORT LEG	2
5	R852030	SPACER, 3/4 x .385 x .203, NYLON	1
6	P852031	BASE PAD	3
7	R852011	CHAIN HOOK	1
8	P852071	JACK FLANGE	3
9	P852026	HANDLE	2
10	R852039	CHAIN, 28 INCHES	1
11	502109	WASHER, 7/16 USS ZINC	1
12	R852010	NYLON WASHER	1
13	502103	NYLON WASHER	6
14	R852009	NYLON SPACER WASHER	6
15	501128	HEX HEAD BOLT, 3/8-16 x 3-1/4, GR. 2	3
16	BAL1012	HEX HEAD BOLT, 3/8-16 x 2-1/2, GR. 2	3
17	R852017	HEX HEAD BOLT, 1/4-20 x 1-3/4, GR. 2	1
18	BAL1014	NYLOK NUT, 3/8-16 ZINC	6
19	R852016	NYLOK NUT, 1/4-20 ZINC	1
20	R858015	GROOVED PIN, 3/16 x 3/4, TYPE A	2
21	R852034	3/8 SHORT PLUG	2
22	R852038	LOCKING CLASP	1
23	R852012	CHAIN, 6 FOOT	1
24	502113	HEX HEAD BOLT, 3/8-16 x 3/4	3
25	50189	WASHER, 3/8 USS ZINC	5
26	R852032	JAM NUT, 3/8-16 ZINC	3
27	825103	GOOSENECK ADAPTER	1

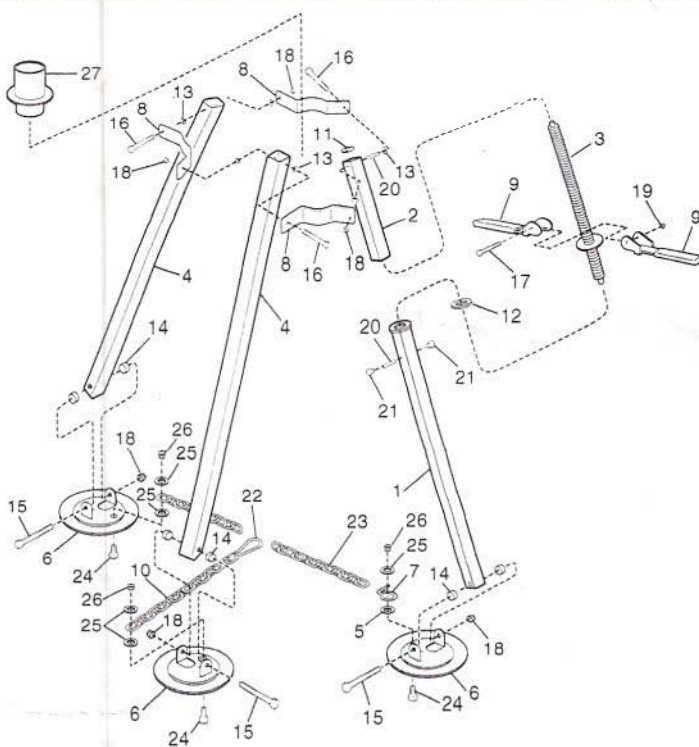

# OPERATING INSTRUCTIONS

**THIS STABILIZING JACK WAS DESIGNED FOR:**  
STABILIZING THE FRONT HALF OF A 5TH WHEEL TRAVEL TRAILER  
BY APPLYING SLIGHT PRESSURE AGAINST THE KING PIN.



## SAFETY WARNINGS:



- **DO NOT** ATTEMPT TO USE THIS JACK FOR LEVELING.
- **DO NOT** ATTEMPT TO USE THIS JACK FOR LIFTING OR TAKING THE LOAD OFF THE TRAILER'S LANDING GEAR.
- **DO NOT** ATTEMPT TO USE THIS STABILIZING JACK FOR ANY PURPOSE OTHER THAN ITS INTENDED DESIGN.
- **DO NOT** PLACE HANDS OR FINGERS ON THE DRIVE SCREW. FOLLOWING THIS INSTRUCTION WILL PREVENT FINGERS AND HANDS FROM BEING PINCHED.

### STABILIZING

1. Position and level the front of your 5th wheel trailer by using your trailer's landing gear.
2. Activate the gooseneck spring loaded locking latch while simultaneously inserting the smaller diameter end of the gooseneck adapter into the gooseneck receiver. Release the locking latch. The spring tension of the locking latch should hold the adapter in place while installing the jack.
3. Raise the king pin jack assembly under the gooseneck adapter until the adapter is located between the jack flanges. The top edges of the flanges should be touching the gooseneck adapter flange. In order to accomplish this, it may be necessary to activate the jack leg.
4. Pull the end of the long chain from the base pad of the support leg through the locking clasp at the end of the short chain. The locking clasp should be positioned approximately midway in the long chain. Pull the long chain snug and place the closest chain link over the open end hook on the base pad of the jacking leg.
5. Pull down the jack leg handles and turn them in a clockwise direction until the chain is taut but not so that it takes the trailer's landing gear off the ground. Remember, the king pin jack is designed for stabilizing not lifting. To test for stability, push on either front corner of the trailer. There should be no side to side movement. Fold up the jack leg handles.
6. Move to the rear of your trailer and crank down your rear jacks.

### REMOVAL

1. Crank up your rear trailer jacks if you have any, then pull down the jack leg handles and turn them in a counterclockwise direction to remove the chain tension and to lower the top edges of the jack flanges from the gooseneck adapter flange.
2. Remove the locking clasp from around the links of the long chain. Disconnect the link of the long chain from the open end hook on the base pad of the jacking leg. Open the legs until the flanges clear the adapter.

