

**WARNING:** For use on stabilizing jacks for travel trailers and 5th wheel campers only. Do not use the Power-Pak on any application other than the intended use specified by BAL. Please contact BAL for any clarification before purchasing.

## Fits SCISSORS JACK Models: 24002C , 24002D, 24003D & 24028

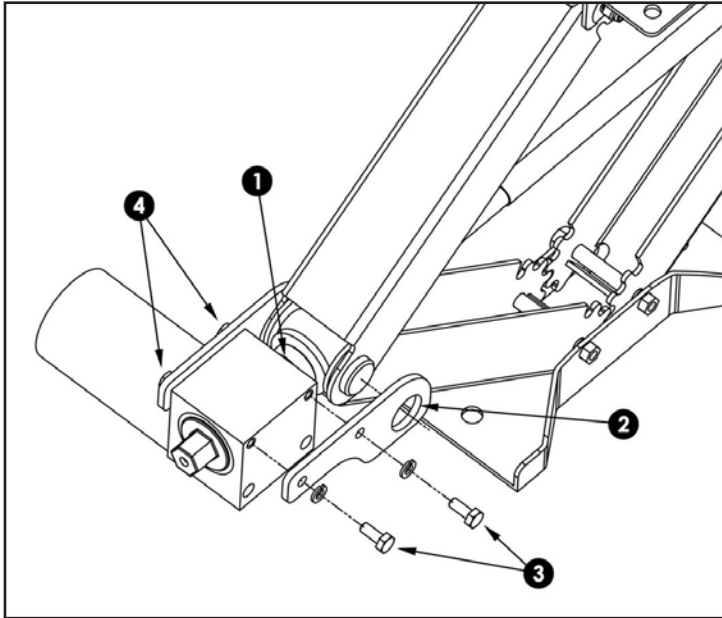

1. Slide motor onto the hex head of the jack's drive screw.
2. Install mounting brackets to outside of scissors jack on 1" diameter trunion.
3. Align all four bracket mounting holes (2 per bracket) to mounting holes in motor.
4. Secure motor to brackets with 1/4"-20x1/2" HHCS and lock washers.
5. Torque bolts to 8 ft/lbs.

## Fits C-JACK Models: 23219, 23222, 23225, 23228 & 23231

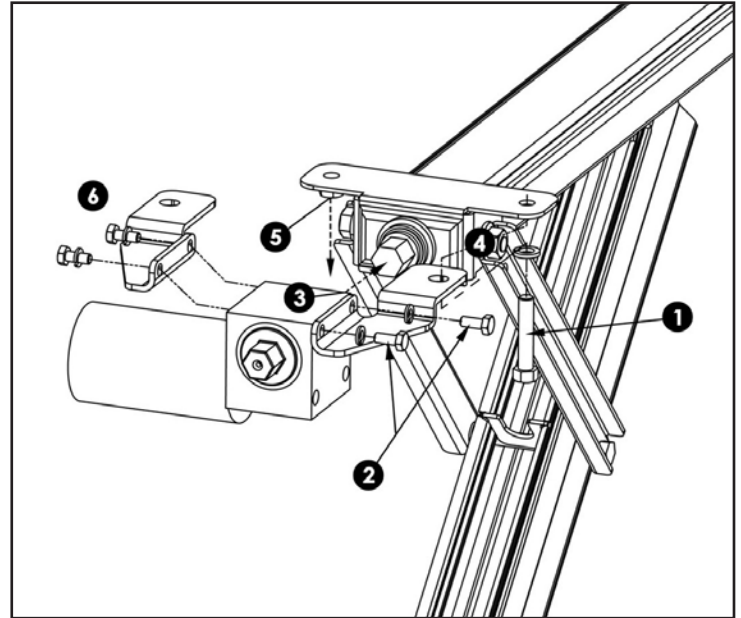

1. Remove one of the front mounting bolts/screws from jack.
2. Loosely attach one mounting bracket to motor with 1/4"-20x1/2" HHCS & lock washers.
3. Slide motor onto the hex-head of the jack's drive screw.
4. Attach motor & bracket to jack using the mounting bolt previously removed.
5. Remove the other front mounting bolt/screw from jack.
6. Repeat Steps 2 & 4 on other side.
7. Tighten all fasteners: 1/4"-20 bolts to 8 ft/lbs; 3/8"-16 bolts to 30 ft/lbs.

## ELECTRICAL DIAGRAM:

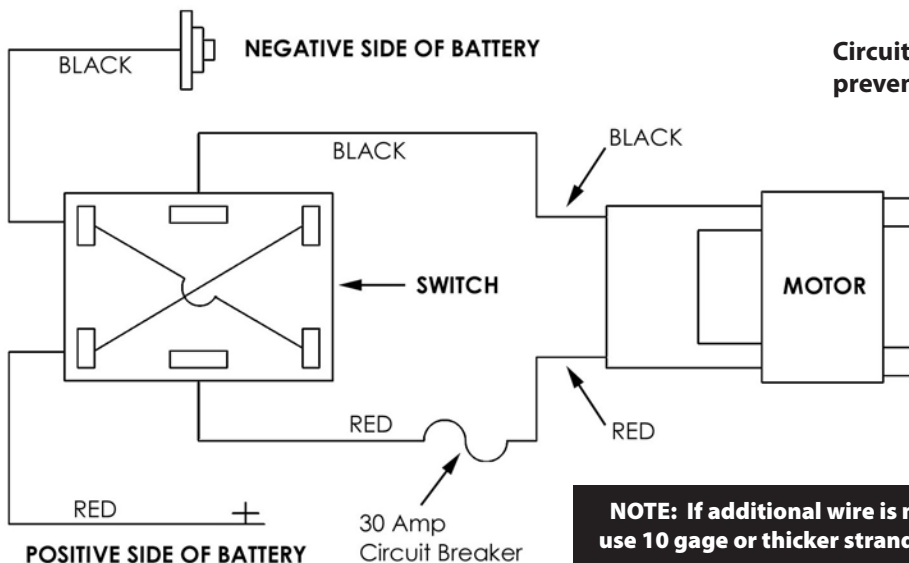

**Circuit breaker must be installed to prevent damage to motor or coach.**

**NOTE: If additional wire is needed, use 10 gage or thicker stranded wire.**



## 24210 Power-Pak Installation and Operating Recommendations

The following recommendations are to help you gain the best functionality and longevity from your BAL Power-Pak Motor Kit.

It is best to wire the positive power line directly to the battery. Each switch must have a dedicated wire running from positive of the battery. No jumping from one switch to the next.

Please use a minimum 10 gauge wire for the install. You might consider 8 gauge for installations on longer trailers.

The 12 volt self resetting breakers need to be installed with each motor; **located between the switch and the motor.** (If you choose to add another fuse or breaker inline at the battery, make sure it is 30 amps.)

Try to install the switches as close to the motors as possible.

The included switches are waterproof however; road grime and debris can cause the switch to stick. Consider installing in a concealed area if possible or using a duplex weatherproof cover on each switch for extra protection.

Under load, only operate one switch at a time.

When operating jacks after trailer is parked, extend the lowest corner jack first and then move to the next lowest corner making your way around the trailer one jack at a time.