

IMPORTANT: READ THE FOLLOWING INFORMATION BEFORE OPERATING YOUR JACK!



LEVELING SCISSORS JACK

FOR USE ON ALL RECREATIONAL VEHICLES

CLASSIC MODELS: 24002C, 24002D, 24003D, 24009, 24010 & 24013

LoPro SJ24 MODELS: 24028 & 24008

INSTALLATION AND OPERATING INSTRUCTIONS

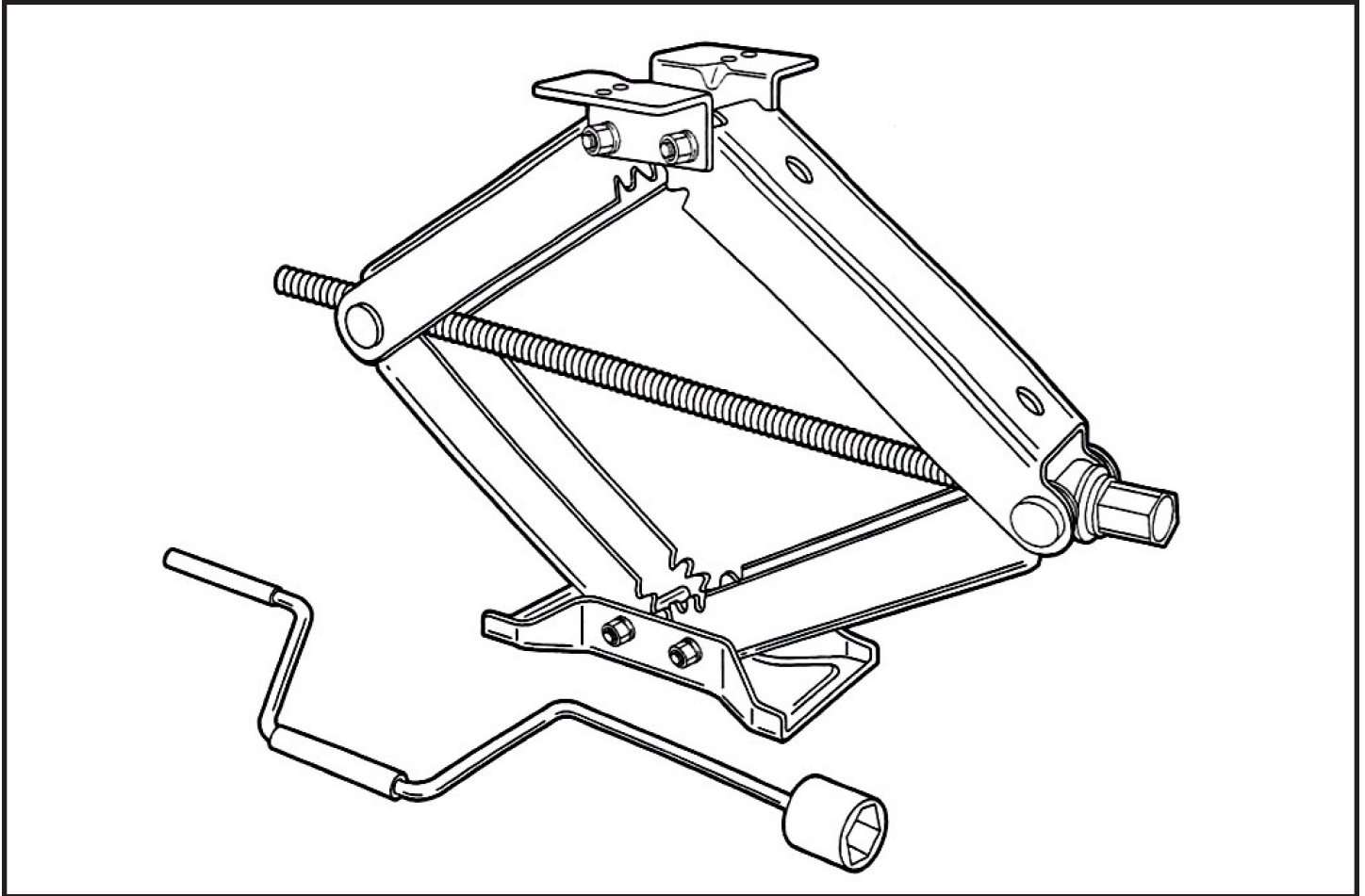

THIS LEVELING SCISSORS JACK IS DESIGNED TO:

LEVEL AND STABILIZE THE FRONT AND REAR OF ALL RECREATIONAL VEHICLES BY REDUCING THE AMOUNT OF SUSPENSION FREE-PLAY WHEN PARKED FOR CAMPING

⚠ WARNING!

- **DO NOT** ATTEMPT TO USE THIS SCISSORS JACK TO LIFT EXCESSIVE WEIGHT OR TIRES OFF THE GROUND - VEHICLE FRAME AND DOOR JAMB DAMAGE MAY OCCUR. USE ONLY STOCK HANDLE SUPPLIED. DO NOT USE A CHEATER BAR ON HANDLE.
- **DO NOT** ATTEMPT TO USE THIS SCISSORS JACK FOR ANY PURPOSE OTHER THAN ITS INTENDED DESIGN.
- **DO NOT** USE THIS SCISSORS JACK AS A TIRE CHANGING JACK.

CAUTION: Some RV's may be designed and manufactured with sub-frames that are not capable of handling additional force over and above the intended strength to support the cabin weight. Contact your RV manufacturer for sub-frame strength information prior to using this Leveling Scissors Jack. NORCO CANNOT BE HELD RESPONSIBLE FOR ANY DAMAGES DUE TO IMPROPER USE OF THIS PRODUCT. NORCO CANNOT BE HELD ACCOUNTABLE FOR THE STRUCTURAL INTEGRITY OF ANY RV FRAME.

PARTS LIST

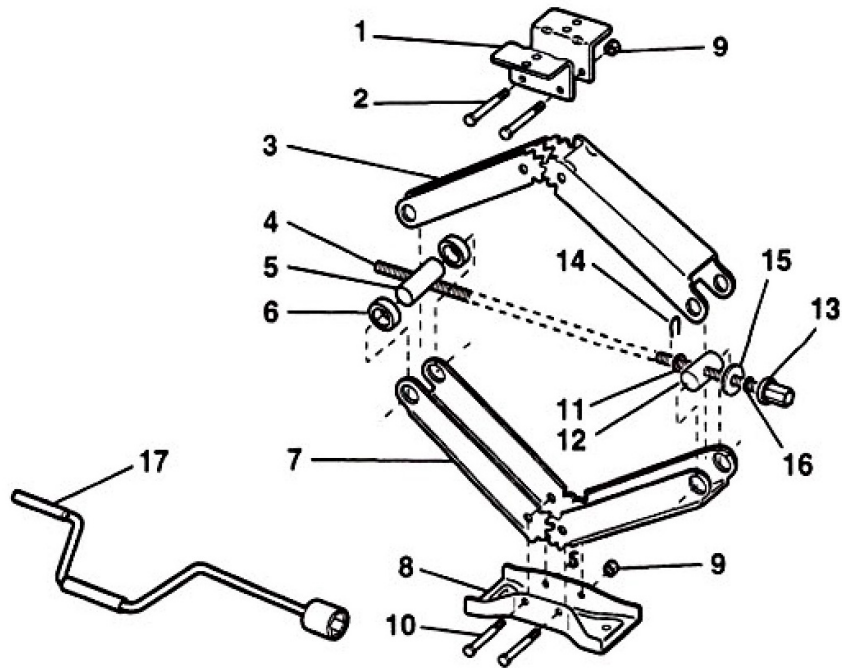

Index No.	Classic Series	LoPro SJ24	Description	Qty
1	P857022	P857095	Mounting Bracket	2
2A	R857066	n/a	3/8-16 x 3" Hex Head Bolt	2
2B	N/A	501352	5/16-18 x .75" Hex Head Bolt	4
3	P10011	N/A	Upper Arm for 24" Jack	2
	P857079	N/A	Upper Arm for 30" Jack	2
	N/A	P857094	Upper Arm for LoPro SJ24 Jack	2
4	P857086	N/A	Drive Screw for 24" Jack	1
	P857049	N/A	Drive Screw for 30" Jack	1
	N/A	P857096	Drive Screw for LoPro SJ24	1
5	857061	857097	Drive Trunnion	1
6	857064	N/A	Plastic Spacer Bushing	2
7	P857024	N/A	Lower Arm for 24" Jack	2
7	P857054	N/A	Lower Arm for 30" Jack	2
7	N/A	P857092	Lower Arm for LoPro SJ24 Jack	2
8	P857028	P857093	Base Pad	1
9	BAL1014	N/A	3/6-16 Nylon Locking Nut	4
9	N/A	851071	5/16-18 Nylon Locking Nut	8
10A	R857065	N/A	3/8-16 x 2 3/4" Hex Head Bolt	2
10B	N/A	R852781	5/16-18 x .75" Carriage Bolt	4
11	BAL2112	BAL2113	5/8 x 1 x 3/16" Washer	1
12	857060	857098	Stationary Trunnion	1
13	R857062	N/A	Thrust Bearing (24010 & 24013)	1
	BAL2111 /857038	N/A	Thrust Washer Assy (24009)	1
	N/A	R857100 /R857100	Plastic Washer / Bronze Washer (24008)	1
14	R857076	R857077	Lock Pin	1
15	P857067	N/A	Spacer/Bearing Washer	1
16	R857075	N/A	O-Ring Brake	1
17	20037	N/A	Crank Handle, Swivel Deluxe 3/4"	1
	N/A	20036	Crank Handle, Fixed 3/4"	1
18	3152	3152	Mounting Screws	4

DETERMINING THE CORRECT MOUNTING LOCATION

NOTE: CHECK GROUND CLEARANCE PRIOR TO INSTALLATION.

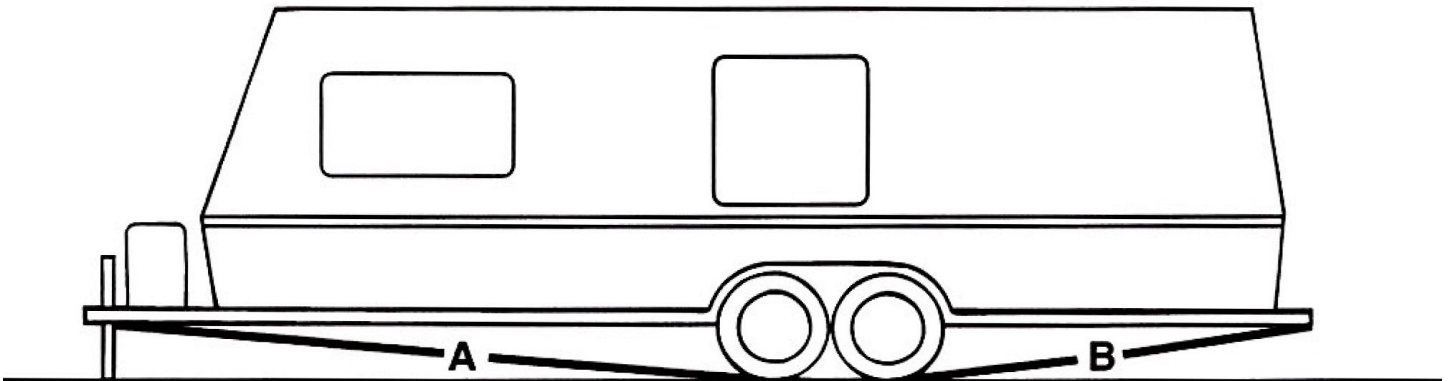

WHEN SELECTING PLACEMENT FOR INSTALLATION...

- Be sure that there is adequate ground clearance.
- Be sure that hex drive will be accessible.
- Be sure that scissors jack does not interfere or come into contact with any under chassis component.

TRAVEL TRAILER AND 5TH WHEEL TRAILER MOUNTING PLACEMENT

STEP 1: PARK ON LEVEL GROUND

FRONT: Draw a string from the front corner of the trailer frame to the bottom of the front tire (A).

REAR: Draw a string from the bottom of the back tire to the back corner of the trailer frame (B).

MOTORHOME MOUNTING PLACEMENT

STEP 1: PARK ON LEVEL GROUND

FRONT: Draw a string from the motorhome front frame extension behind the front bumper to the bottom of the front tire (A).

REAR: Draw a string from the bottom of the back tire to the back corner of the motorhome frame (B).

NOTE: ANY OBJECT PROTRUDING BELOW THESE LINES CAN BE DAMAGED, DRAGGED OFF OR DESTROYED IN UNEVEN TERRAIN, ENTERING OR EXITING DRIVEWAYS, DRIVING OFF ROAD, ETC.

BEFORE PROCEEDING TO INSTALLATION - PERFORM THIS IMPORTANT TEST

To insure clearance for the jack in the closed position, clamp the jack to the vehicle frame using two "C" clamps or Vise Grips™. Close the jack with the crank handle and check to insure that the location chosen will allow the jack to close without coming into contact with or obstruct any under chassis components (ie: plumbing, exhaust, etc.)

CAUTION: Some RV's may be designed and manufactured with sub-frames that are not capable of handling additional force over and above the intended strength to support the cabin weight. Contact your RV manufacturer for sub-frame strength information prior to using this Leveling Scissors Jack. NORCO CANNOT BE HELD RESPONSIBLE FOR ANY DAMAGES DUE TO IMPROPER USE OF THIS PRODUCT. NORCO CANNOT BE HELD ACCOUNTABLE FOR THE STRUCTURAL INTEGRITY OF ANY RV FRAME.

INSTALLATION

STEP 1: Park RV on level ground. Prevent wheels from rolling by activating emergency brake and/or by using tire chocks.

STEP 2: BEFORE PROCEEDING TO INSTALLATION - PERFORM THIS IMPORTANT TEST

To insure clearance for the jack in the closed position, clamp the jack to the vehicle frame using two "C" clamps or Vise Grips™. Close the jack with the crank handle and check to insure that the location chosen will allow the jack to close without coming into contact with or obstruct any under chassis components (ie: plumbing, exhaust, etc.)

- Open the jack until it touches the ground. Recheck location and adjust as needed.

- Once in place, apply enough pressure so jack cannot move during installation procedure. Remove clamps or Vise Grips™.

BOLT-ON INSTALLATION

WARNING: BEFORE DRILLING HOLES, BE SURE THE DRILL WILL NOT DAMAGE UNDER CHASSIS COMPONENTS WHICH MAY BE ROUTED INSIDE VEHICLE FRAME (ie: electrical, gas, water, generator fuel lines, holding tank plumbing, water heater).

Refer to **STEP 1** and **STEP 2** above.

STEP 3: Using the mounting plate as a template, mark the locations of the four mounting holes on the vehicle frame. Remove the jack.

STEP 4: Mark the center of each hole location with a center punch and hammer.

STEP 5: Drill a 1/8" pilot hole and finish by drilling holes with a 5/16" diameter drill.

STEP 6: Reposition jack. Use a 9/16" socket and ratchet to install the jacks to the vehicle frame using four screws and four lock washers per jack (Figure 1).

WELD-ON INSTALLATION

Refer to **STEP 1** and **STEP 2** above.

STEP 3: Weld each mounting plate to the vehicle frame with 4 each 1" welds, as shown (Figure 2).

Figure 1

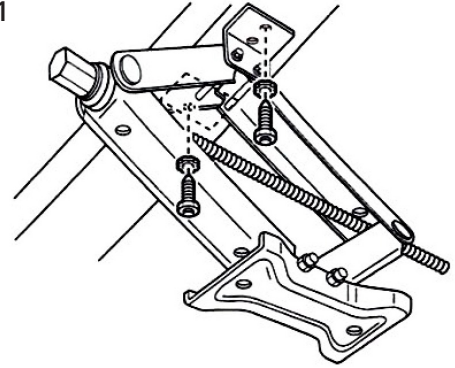
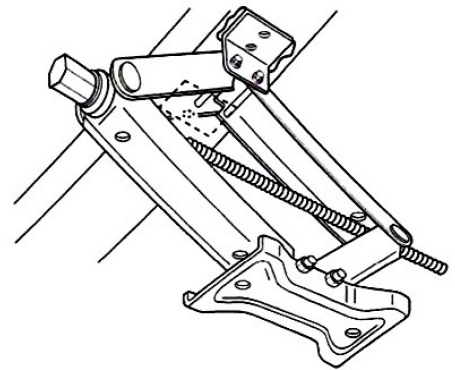

Figure 2



OPERATION

STEP 1: Park RV on level ground, prevent wheels from rolling, use tire chocks.

STEP 2: Level trailer fore and aft using tongue jack or landing gear.

STEP 3: Check level gauge for low side of trailer, crank down stabilizers on low side first, bringing the trailer to a fine level position.

STEP 4: Crank down stabilizers on opposite side of trailer to insure maximum stability. Then re-snug stabilizers on low side of trailer if necessary.

NOTE: BEFORE MOVING TRAILER: Crank up stabilizers to fully closed position and tighten 1/4 turn to secure in travel position (this prevents stabilizers from working open due to road vibration).

MAINTENANCE: Use small amounts of WD-40 or similar lubricant on drive screw threads and bolt locations as required.

WARNING: DO NOT ATTEMPT TO USE THIS SCISSORS JACK TO LIFT EXCESSIVE WEIGHT OR TIRES OFF OF THE GROUND - VEHICLE FRAME AND DOOR JAMB DAMAGE MAY OCCUR. USE ONLY STOCK HANDLE SUPPLIED. DO NOT USE A CHEATER BAR ON HANDLE. DO NOT USE THIS SCISSORS JACK AS A TIRE CHANGING JACK.